

Installation Instructions

5201015 Vise Mount

The 5201015 bumper vise mount is suitable for installation on most mechanics, service and utility body bumpers. Its pre-punched mounting holes accommodate Wilton® vises with 3-1/2", 4" or 4-1/2" bolt centers including these models: AW35, AW350S, 400S, AW45, 450S, C-0, C-2 AND 2040.

INSTRUCTIONS:

1. Locate the 3035761 vise base plate and 3035762 vise mount on the truck body bumper and assemble with 1/2" fasteners. Set the vise on the assembly to confirm the desired mounting height.
2. Mark the four mounting holes on the base plate and drill 9/16" holes.
3. Before final assembly, cut off unused mounting holes on the vise plate and round the corners with a grinder.
4. Assemble with provided 1/2" fasteners and appropriate thread locker.

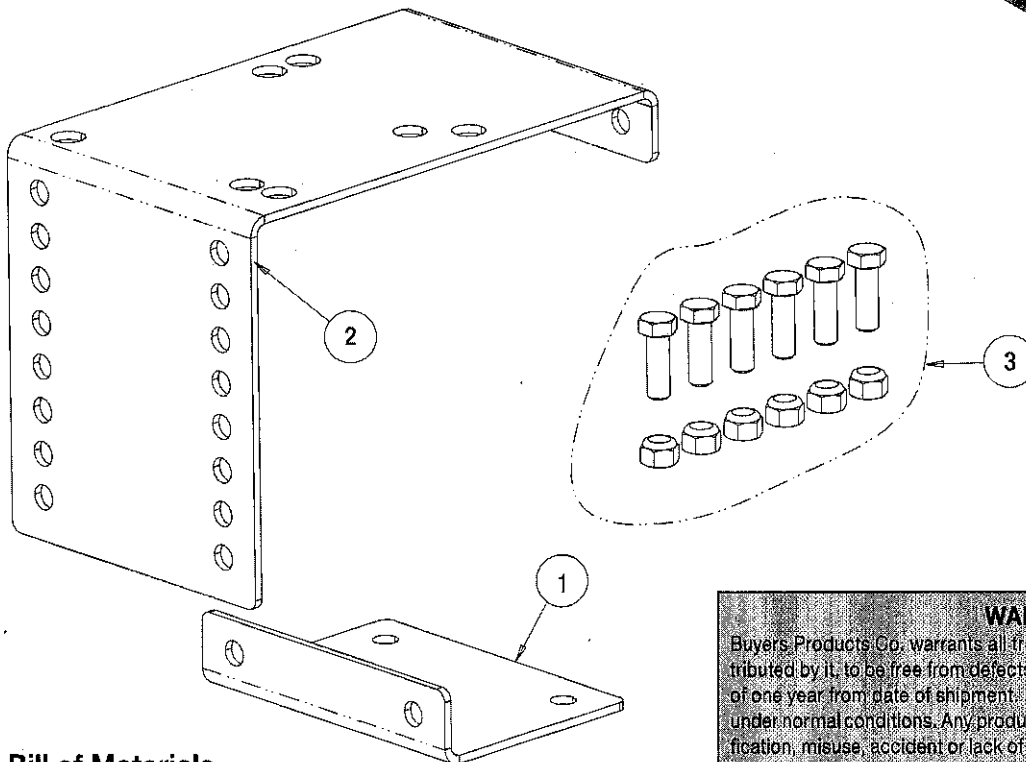
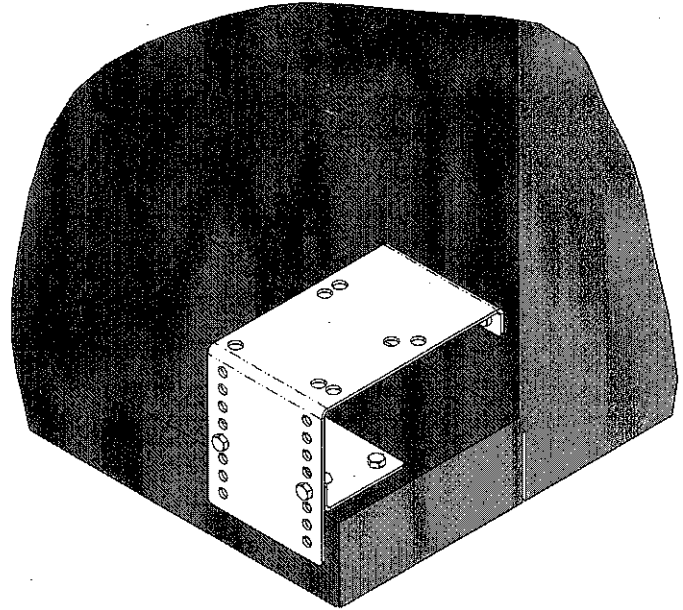

Bill of Materials

ITEM	PART NO.	QTY.	DESCRIPTION
1	3035761	1	PLATE, BASE, VISE MOUNT
2	3035762	1	PLATE, MOUNT, VISE
3	3035763	1	HARDWARE BAG, 5201015

WARRANTY

Buyers Products Co. warrants all truck/trailer hardware manufactured or distributed by it, to be free from defects in material and workmanship for a period of one year from date of shipment. Parts must be properly installed and used under normal conditions. Any product which has been altered, including modification, misuse, accident or lack of maintenance will not be considered under warranty. Normal wear is excluded. The sole responsibility of Buyers Products Co. under this warranty is limited to repairing or replacing any part or parts which are returned, prepaid, and are found to be defective by Buyers Products Co. Authorization from Buyers Products Co. must be obtained before returning any part. No charges for transportation or labor performed on Buyers' products will be allowed under this warranty.