

Installation Instructions

8895105 Drill-Free Light Bar Cab Mount

Chevrolet Colorado & GM Canyon, 2015 - 2022

These instructions provide all the necessary directions and information to allow your Drill-Free Light Bar Cab Mount to be safely and properly installed. Before beginning the installation of your new Drill-Free Light Bar Cab Mount, please have the installer and the operator read these directions thoroughly. Important information regarding the safe installation and safe operation of your Drill-Free Light Bar Cab Mount is contained that could prevent serious damage and injury to yourself or others.

The Drill-Free Light Bar Cab Mount is designed to facilitate the quick and simple installation of devices normally mounted to the roof of a pickup truck. Our product provides a durable platform onto which these devices may be mounted without requiring holes to be drilled into the cab roof for fastening or wiring access. This Drill-Free Light Bar Cab Mount provides a system of weather-resistant gaskets and deflectors designed to redirect wind and moisture in common applications. **PLEASE NOTE: the Drill-Free Light Bar Cab Mount is not designed to be weather-proof in the event of power washing, mechanical car washing, or other forces beyond normal highway operation.**

It is the responsibility of the owner/operator to periodically inspect the Drill-Free Light Bar Cab Mount to be sure the clamping system remains secure and the weather resistant gasketing is snug.

The Drill-Free Light Bar Cab Mount is designed to provide a mounting platform for lighting, antennas, GPS, and other devices. In no way is the Drill-Free

Light Bar Cab Mount to be used as a load bearing rack for ladders or other equipment or supplies. The recommended weight restriction of the Drill-Free Light Bar Cab Mount is 30 lbs.

The Drill-Free Light Bar Cab Mount is designed to provide a mounting platform but in no way provides advice on the possible electronic effect of mounting various devices within any proximity to another. The Drill-Free Light Bar Cab Mount is manufactured of powder coated aluminum but is mounted to the vehicle with gaskets to provide a water-resistant bond and protect the finish of the vehicle. As such, the Drill-Free Light Bar Cab Mount may not be grounded to the vehicle without the installation technician applying an appropriate grounding mechanism.

MOUNTING THE UNIT:

The Drill-Free Light Bar Cab Mount has been developed with five vehicle specific platforms. Each model shares the same clamping method, gasketing system, and deck dimensions. **NOTE: To maximize success of the water resistant seal, the Light Bar Mount must be centered and level on the vehicle when installed.**

1. Mount Preparation: Open package and remove all parts from shipping position inside the box.

2. Platform Preparation: Mount and fasten lights and other apparatuses to be installed on the upper surface of the platform, attaching and fastening each to their manufacturers' installation requirements. All wiring should include 8 to 10 inch leads and connectors. At the same time, make up the corresponding wire harness for connection inside the vehicle. Lengths will vary. **NOTE: Fasteners are not to project more than 3/8" below bottom surface of the mounting area for risk of damaging vehicle. Pan-head fasteners are recommended.**

3. Vehicle Preparation: Remove the mounting screws securing the CHMSL (Cab High Mount Stop Light). Remove light housing from truck body, detach wiring connector, and set aside for re-installation at end of the upfit.

4. Install the corresponding apparatus wiring harness through the CHMSL hole into the vehicle and snake through the interior for connection. Be sure to leave enough wire length for maneuvering and attachment of connectors at the end of the upfit.

5. Remove the two clamps from the assembly. Pull all harness wires and CHMSL lead through the access holes. Position the Platform Assembly onto the CHMSL mount area of the vehicle, centered on the opening. Compress the bottom foam strip such that the registration tabs capture the bottom edge of the vehicle opening.

6. Installation of the Platform: One at a time, insert each clamp into the outer vehicle aperture, then insert mounting bolts thru the platform mounting hole and align with clamp holes. Carefully adjust the location of the clamps to maximize hole alignment and thread bolt in loosely.

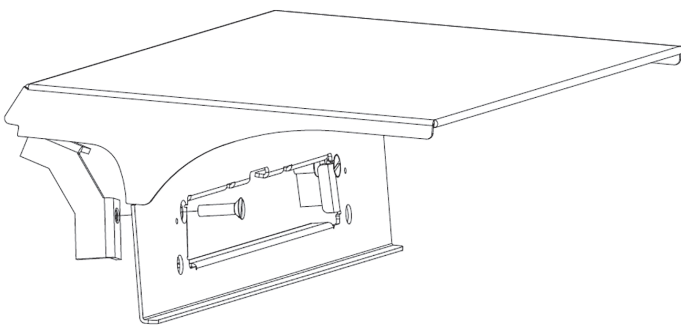

7. Final Securing of the Platform: BE SURE TO CENTER AND LEVEL THE PLATFORM ON THE VEHICLE CAB. Holding the Platform Assembly firmly against the vehicle, tighten the clamp adjustment fasteners to take up the slack until the gaskets fit uniformly against the profile of the cab body and compress the leading edge deflector gasket. Sight the top of the endcaps as a reference for level and true. Final tighten both clamp fasteners equally, 15-18 ft/lbs each.

8. Connect the new apparatus' wiring harnesses and test. Reconnect the CHMSL harness, and reinstall light housing into Platform Assembly with original fasteners.

9. A strip of self-adhesive weather stripping is included to adhere to vehicle roof overlapping the front edge of the unit as added protection of the leading edge gaskets. This is strongly recommended to avoid ice buildup.

Warranty

Buyers Products Co. warrants all truck/trailer hardware manufactured or distributed by it, to be free from defects in material and workmanship for a period of one year from date of shipment. Parts must be properly installed and used under normal conditions. Any product which has been altered, including modification, misuse, accident or lack of maintenance will not be considered under warranty. Normal wear is excluded. The sole responsibility of Buyers Products Co. under this warranty is limited to repairing or replacing any part or parts which are returned, prepaid, and are found to be defective by Buyers Products Co. Authorization from Buyers Products Co. must be obtained before returning any part. No charges for transportation or labor performed on Buyers' products will be allowed under this warranty.