

Installation and Operator's Manual

LT19 (2 Position) & LT21 (3 Position) Lockable Trimmer Racks for Utility Landscape Trailers

GENERAL SAFETY PRECAUTIONS



This symbol points out important safety instructions which, if not followed, could endanger the personal safety and/or property of yourself and others. Read and follow all instructions in this manual before attempting to install or operate this Lockable Trimmer Rack. Failure to comply with these instructions may result in personal injury. When you see this symbol. **HEED ITS WARNING!**



WARNING

Improper installation and operation could cause personal injury, and/or property damage. Observe the following Safety Precautions before, during and after operating this spare tire carrier. By following these precautions and common sense, possible injury to persons and potential damage to this accessory may be avoided.

BEFORE YOU BEGIN INSTALLING:

1. Read and understand these instructions completely.
2. Verify that you have received all the parts listed in the bill of materials.



WARNING

Always wear safety glasses when using power tools.

Tools Required:

- 1/2" Wrench and/or sockets
- 7/16" Wrench and/or sockets
- Electric Drill
- 11/32" Drill Bit
- Carpenter's Square
- Tape Measure
- (2) C-clamps

1. Clamp the locking and nonlocking uprights to the trailer side rail approximately 28" to 34" apart with the base of the upright on the trailer floor. The locking upright may be assembled on the left or right of the nonlocking upright. Verify the uprights are square to the trailer deck in both directions with a carpenter's square. **Note: If bent shaft**



- trimmers are used, the uprights need to be mounted closer together than if straight shaft trimmers are used.*
2. Assemble a line trimmer to the rack to verify the distance between the uprights is correct for the model of trimmer you wish to hold. **Note: The large hook on the locking upright should engage the trimmer's grip and the smaller hook on the nonlocking upright should engage the shaft of the trimmer. Do not clamp on or near the throttle trigger of the trimmer. With the trimmer assembled in position, verify that the lock assembly hook can rotate freely over the trimmer grip.**
 3. Clamp the two uprights to the rail of the trailer. Make sure the uprights are square to the rail and the deck of the trailer with a square.
 4. Mark the center of the two holes on each rail.



WARNING

Check for locations of brake lines and electrical wiring etc., before drilling any holes. Any damage to trailer during installation is the installer's sole responsibility.

5. Drill two 11/32" holes through the marked locations.
6. Fasten each upright to the trailer with two 5/16-18 x 1-1/2" cap screws, four 5/16" flat washers, and two 5/16-18" nylock nuts. Tighten all four screws.

MAINTENANCE

Examine the general condition of the Lockable Trimmer Rack for any damage or worn parts before installation and monthly after mounted to your trailer. Check all nuts and bolts to make sure they are secure and tight monthly. Have necessary repairs made by qualified service personnel.

LT19 (2 Position) Bill of Materials

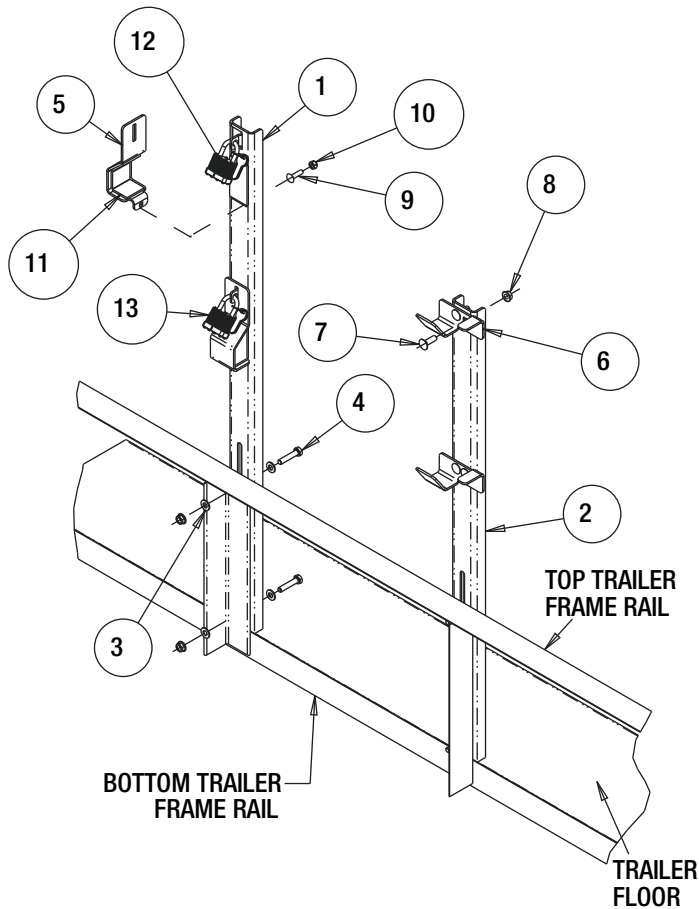

ITEM	PART NO.	QTY.	DESCRIPTION
1	3054057	1	RACK, TRIMMER (2), REAR STANSION
2	3054056	1	RACK, TRIMMER (2), FRONT STANSION
3	FWF031075006	8	WASHER, 5/16 SAE TYPE A ZINC
4	FCS031018150	4	SCREW, HHC 5/16-18 X 1.5 GR 5 ZN
5	3053883	2	BRACKET, HINGELESS
6	3053819	2	CLAMP, TRIMMER RACK
7	3026934	4	BOLT, CARRIAGE, 5/16-18 X 1 SST
8	3003777	8	NUT, SERRATED FLANGE 5/16-18 ZINC
9	FCB025020050SS	2	BOLT, RHSQN,.25-20X.5 SST
10	FNE025020031SS	2	NUT, NYLOCK, 1/4-20, GR A, SST
11	3056047	6	CUSHION, FOAM, TRIMMER RACK
12	3043332	2	PAD,FOAM,W/PSA,CROSSBOX, 0.25 FT PIECE CUT
13	3045148	1	LOCK KIT,(2) 1-1/2" LOCKS W/BUMPER KEYED ALIKE

LT19 (3 Position) Bill of Materials

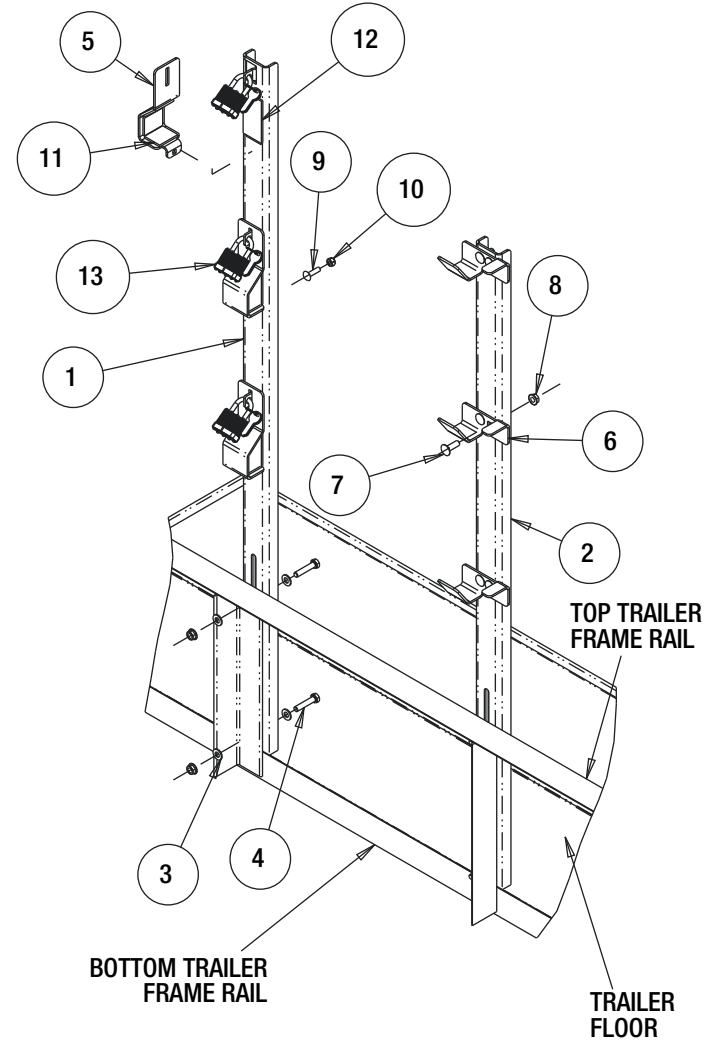

ITEM	PART NO.	QTY.	DESCRIPTION
1	3056128	1	RACK, TRIMMER (3), REAR STANSION
2	3056129	1	RACK, TRIMMER (3), FRONT STANSION
3	FWF031075006	8	WASHER, 5/16 SAE TYPE A ZINC
4	FCS031018150	4	SCREW, HHC 5/16-18 X 1.5 GR 5 ZN
5	3053883	3	BRACKET, HINGELESS
6	3053819	3	CLAMP, TRIMMER RACK
7	3026934	6	BOLT, CARRIAGE, 5/16-18 X 1 SST
8	3003777	10	NUT, SERRATED FLANGE 5/16-18 ZINC
9	FCB025020050SS	3	BOLT, RHSQN,.25-20X.5 SST
10	FNE025020031SS	3	NUT, NYLOCK, 1/4-20, GR A, SST
11	3056047	9	CUSHION, FOAM, TRIMMER RACK
12	3043332	3	PAD,FOAM,W/PSA,CROSSBOX, 0.25 FT PIECE CUT
13	3006320	1	LOCK KIT,(3) 1-1/2" LOCKS W/BUMPER KEYED ALIKE

Warranty

Buyers Products Co. warrants all truck/trailer hardware manufactured or distributed by it, to be free from defects in material and workmanship for a period of one year from date of shipment. Parts must be properly installed and used under normal conditions. Any product which has been altered, including modification, misuse, accident or lack of maintenance will not be considered under warranty. Normal wear is excluded. The sole responsibility of Buyers Products Co. under this warranty is limited to repairing or replacing any part or parts which are returned, prepaid, and are found to be defective by Buyers Products Co. Authorization from Buyers Products Co. must be obtained before returning any part. No charges for transportation or labor performed on Buyers' products will be allowed under this warranty.