



# Demco

## Brakes

### 10" x 2 1/4" Standard/Marine



**FREE BACKING**



**UNI-SERVO**

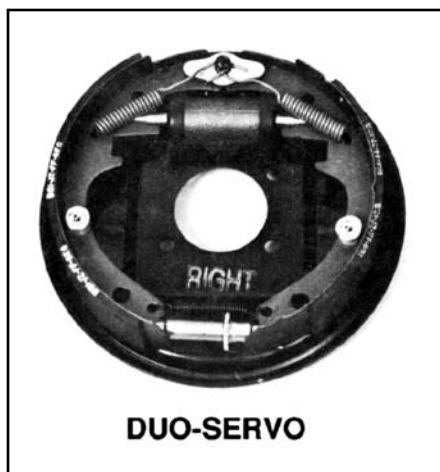

**DUO-SERVO**



**SELF ADJUSTING**

**ASSEMBLY  
CALIBRATION  
OPERATION  
REPLACEMENT PARTS**

**READ** *complete manual CAREFULLY  
BEFORE attempting operation.*

Doing Our Best to Provide You the Best

OPERATORS MANUAL



 **WARNING: To Prevent Serious Injury or Death**

FAILURE TO FOLLOW THESE INSTRUCTIONS, OR FAILURE TO PROPERLY MAINTAIN BRAKES AFTER INSTALLATION, CAN RESULT IN LOSS OF BRAKING ACTION. THIS CAN CAUSE PERSONAL INJURY, DEATH OR PROPERTY DAMAGE. ONLY PROFESSIONAL MECHANICS SHOULD INSTALL BRAKE CLUSTERS. HAVE YOUR BRAKES INSPECTED BY A PROFESSIONAL MECHANIC AT LEAST ANNUALLY AFTER INSTALLATION.

 **WARNING: To Prevent Serious Injury or Death**

- Review following instructions before installation and use of hydraulic brakes.
- Dealers or distributors must review these instructions with ultimate user.
- Failure to follow these instructions, or failure to properly maintain braking system after installation, can result in loss of braking action.

**Table of Contents**

General information.....	3
Safety, Signal Words .....	4
Equipment Safety Guidelines.....	5
Remember .....	5
Before Operation .....	5-6
During Operation.....	6-7
Following Operation .....	7
Highway and Transport Operations .....	7
Performing Maintenance .....	8
Bolt Torque .....	9
Brake Installation and Maintenance .....	10-11
Standard, Marine, & New Departure Hub(NDH) Free Backing Breakdown & Parts List....	12
Standard, Marine, & NDH Uni-Servo Breakdown & Parts List.....	13
Standard & HDH Duo-Servo Breakdown & Parts List.....	14
Standard & NDH Self Adjusting Breakdown & Parts List.....	15

## SAFETY

**TAKE NOTE! THIS SAFETY ALERT SYMBOL FOUND THROUGHOUT THIS MANUAL IS USED TO CALL YOUR ATTENTION TO INSTRUCTIONS INVOLVING YOUR PERSONAL SAFETY AND SAFETY OF OTHERS. FAILURE TO FOLLOW THESE INSTRUCTIONS CAN RESULT IN INJURY OR DEATH.**



**THIS SYMBOL MEANS**

**ATTENTION**

**BECOME ALERT**

**YOUR SAFETY IS INVOLVED!**

### **SIGNAL WORDS**

Note use following signal words **DANGER**, **WARNING**, and **CAUTION** with safety messages. Appropriate signal word for each has been selected using following guidelines:

#### **DANGER:**

Indicates an imminently hazardous situation that, if not avoided, will result in death or serious injury. This signal word is to be limited to most extreme situations typically for machine components which, for functional purposes, cannot be guarded.

#### **WARNING:**

Indicates a potentially hazardous situation that, if not avoided, could result in death or serious injury, and includes hazards that are exposed when guards are removed. It may also be used to alert against unsafe practices.

#### **CAUTION:**

Indicates a potentially hazardous situation that, if not avoided, may result in minor or moderate injury. It may also be used to alert against unsafe practices.

If you have questions not answered in this manual, require additional copies, or if your manual is damaged, please contact your dealer or Demco, P.O. Box 189, 4010 320th Street, Boyden, IA 51234  
ph: (712) 725-2311 or (712) 725-2302 Toll Free: 1-800-543-3626 Fax: (712) 725-2380

<http://www.demco-products.com>



## **SAFETY...YOU CAN LIVE WITH IT**



### **EQUIPMENT SAFETY GUIDELINES**

Every year many accidents occur which could have been avoided by a few seconds of thought and a more careful approach to handling equipment. You the operator, can avoid many accidents by observing and following precautions in this section. To avoid personal injury, study the following precautions and insist those working with you, or you yourself, follow them.

In order to provide a better view, certain illustrations in this manual may show an assembly with a safety shield removed. However, equipment should never be operated in this condition. Keep all shields in place. If shield removal becomes necessary for repairs, replace shield prior to use.

Replace any caution, warning, danger or instruction safety decal that is not readable or is missing. Location of such decals is indicated in this booklet.

Do not attempt to operate this equipment under the influence of alcohol or drugs.

Review safety instructions with all users.

Operator should be a responsible adult. **DO NOT ALLOW PERSONS TO OPERATE OR ASSEMBLE THIS UNIT UNTIL THEY HAVE DEVELOPED A THOROUGH UNDERSTANDING OF SAFETY PRECAUTIONS AND HOW IT WORKS.**

Never exceed limits of brakes. If its ability to do a job, or to do so safely is in question-**DON'T TRY IT.**



### **REMEMBER**

Your best assurance against accidents is a careful and responsible operator. If there is any portion of this manual or function you do not understand, contact your local authorized dealer or manufacturer.



### **BEFORE OPERATION:**

- Carefully study and understand this manual.
- Always wear protective clothing and substantial shoes.
- Give equipment a visual inspection for any loose bolts, worn parts, or cracked welds, and make necessary repairs. Follow maintenance safety instructions included in this manual.
- Be sure there are no tools lying on or in equipment.

- Do not use equipment until you are sure that area is clear, especially around children and animals.
- Don't hurry learning process or take equipment for granted. Ease into it and become familiar with your new equipment.
- Practice operation of your equipment and its attachments. Completely familiarize yourself and other operators with its operation before using.
- Make sure that brakes are evenly adjusted.
- Make sure tow rating on vehicle is high enough for what it is towing.
- Do not allow anyone to stand between tongue or hitch and towing vehicle when backing up to equipment.
- Securely attach to towing vehicle. Use appropriately sized hitch ball and/or hitch pin with a mechanical retainer and attach safety chains.
- Criss cross chains under tongue and secure to draw bar cage, mounting loops, or bumper frame.



### **DURING OPERATION**

- **SAFETY CHAINS** If equipment is going to be transported on a public highway, safety chains should be obtained and installed. Always follow state and local regulations regarding safety chains and auxiliary lighting when towing equipment on a public highway. Be sure to check with local law enforcement agencies for your own particular regulations. Only safety chains (not an elastic or nylon/plastic tow straps) should be used to retain connection between towing and towed equipment in event of separation of primary attaching system.
- Install safety chains by criss crossing chains under tongue and secure to draw bar cage, mounting loops, or bumper frame.
- Beware of bystanders, **PARTICULARLY CHILDREN!** Always look around to make sure it is safe to start engine of towing vehicle or move equipment. This is particularly important with higher noise levels, as you may not hear people shouting.
- **NO PASSENGERS ALLOWED-** Do not carry passengers anywhere on or in equipment.
- Do not clean, lubricate, or adjust your equipment while it is moving.
- When halting operation, even periodically, set towing vehicles parking brake, shut off engine, and **remove the ignition key.**
- Be extra careful when using on inclines.
- **MANEUVER TOWING UNIT AT SAFE SPEEDS.**
- Avoid loose gravel, rocks, and holes, they can be dangerous for equipment operation or movement.
- Allow for overall length when making turns.

- Keep all bystanders and pets clear of work area.
- Operate towing vehicle from operators seat only.
- Never leave running equipment attachments unattended.
- As a precaution, always recheck hardware on equipment following every 100 hours or 50 miles. Correct all problems. Follow maintenance safety procedures.



### **FOLLOWING OPERATION**

- Following operation, or when unhitching, stop towing vehicle, set brakes, shut off the engine and **remove ignition key**.
- Store unit in an area away from human activity.
- Do not permit children to play on or around stored unit.
- Make sure all parked units are on a hard, level surface and engage all safety devices.
- Wheel chocks may be needed to prevent unit from rolling.



### **HIGHWAY AND TRANSPORT OPERATIONS**

- Adopt safe driving practices:
  - Always drive at a safe speed relative to local conditions and ensure that your speed is low enough for an emergency stop.
  - Reduce speed prior to turns to avoid risk of overturning.
  - Always keep towing vehicle in gear to provide engine braking when going downhill. Do not coast.
  - Do not drink and drive!
- Comply with state and local laws governing highway safety on public roads.
- Use approved accessory lighting, flags and necessary warning devices to protect operators of other vehicles on highway during transport. Various safety lights and devices are available from your dealer.
- Local laws should be checked for all highway lighting and marking requirements.
- Plan your route to avoid heavy traffic.
- Be a safe and courteous driver. Always yield to oncoming traffic in all situations, including narrow bridges, intersections, etc.
- Be observant of bridge loading ratings. Do not cross bridges rated lower than the gross weight at which you are operating.
- Watch for obstructions overhead and side to side while transporting.
- Always operate equipment in a position to provide maximum visibility at all times. Make allowances for increased length and weight of equipment when making turns and/or stop.



## **PERFORMING MAINTENANCE**

- Good Maintenance is your responsibility. Poor maintenance is an invitation to trouble.
- Make sure there is plenty of ventilation. Never operate engine of towing vehicle in a closed building. Exhaust fumes may cause asphyxiation.
- Before working on this unit, stop towing vehicle, set parking brakes, shut off engine and **remove ignition key**.
- Be certain all moving parts and attachments have come to a complete stop before attempting to perform maintenance.
- Always use safety supports and block wheels. Never use a jack to support unit.
- Always use proper tools or equipment for job at hand.
- Use extreme caution when making adjustments.
- Follow torque chart in this manual when tightening bolts and nuts.
- Openings in skin and minor cuts are susceptible to infection from brake fluid.  
**Without immediate medical treatment, serious infection and reactions can occur.**
- Replace **all shields** and **guards** after servicing and before moving.
- After servicing, be sure all tools, parts and service equipment are removed.
- Do not allow grease or oil to build up on the brake.
- When replacing bolts, refer to owners manual.
- Refer to bolt torque chart for head identification marking.
- Where replacement parts are necessary for periodic maintenance and servicing, genuine factory replacement parts must be used to restore your equipment to original specifications. Manufacturer will not claim responsibility for use of unapproved parts or accessories and other damages as a result of their use.
- If equipment has been altered in any way from original design, manufacturer does not accept any liability for injury or warranty.
- A fire extinguisher and first aid kit should be kept readily accessible while performing maintenance on this equipment



## BOLT TORQUE

### TORQUE DATA FOR STANDARD NUTS, BOLTS, AND CAPSCREWS.

Tighten all bolts to torques specified in chart unless otherwise noted. Check tightness of bolts periodically, using bolt chart as guide. Replace hardware with same grade bolt.

NOTE: Unless otherwise specified, high-strength Grade 5 hex bolts are used throughout assembly of equipment.

#### Bolt Torque for Standard bolts \*



#### Torque Specifications

"A"	GRADE 2		GRADE 5		GRADE 8	
	lb-ft	(N.m)	lb-ft	(N.m)	lb-ft	(N.m)
1/4"	6	(8)	9	(12)	12	(16)
5/16"	10	(13)	18	(25)	25	(35)
3/8"	20	(27)	30	(40)	45	(60)
7/16"	30	(40)	50	(70)	80	(110)
1/2"	45	(60)	75	(100)	115	(155)
9/16"	70	(95)	115	(155)	165	(220)
5/8"	95	(130)	150	(200)	225	(300)
3/4"	165	(225)	290	(390)	400	(540)
7/8"	170	(230)	420	(570)	650	(880)
1"	225	(300)	630	(850)	970	(1310)

#### Bolt Torque for Metric bolts \*

"A"	CLASS 8.8		CLASS 9.8		CLASS 10.9	
	lb-ft	(N.m)	lb-ft	(N.m)	lb-ft	(N.m)
6	9	(13)	10	(14)	13	(17)
7	15	(21)	18	(24)	21	(29)
8	23	(31)	25	(34)	31	(42)
10	45	(61)	50	(68)	61	(83)
12	78	(106)	88	(118)	106	(144)
14	125	(169)	140	(189)	170	(230)
16	194	(263)	216	(293)	263	(357)
18	268	(363)	--	--	364	(493)
20	378	(513)	--	--	515	(689)
22	516	(699)	--	--	702	(952)
24	654	(886)	--	--	890	(1206)

Torque figures indicated are valid for non-greased or non-oiled threads and heads unless otherwise specified. Therefore, do not grease or oil bolts or capscrews unless otherwise specified in this manual. When using locking elements, increase torque values by 5%.

\* GRADE or CLASS value for bolts and capscrews are identified by their head markings.

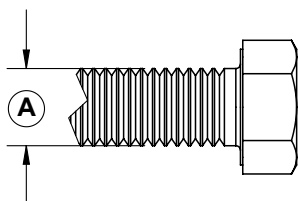

GRADE-2

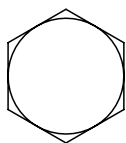

GRADE-5

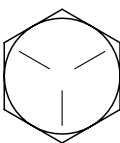

GRADE-8

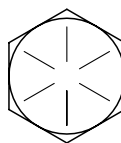

CLASS 8.8

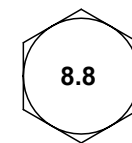

CLASS 9.8

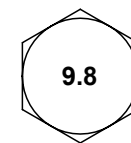

CLASS 10.9

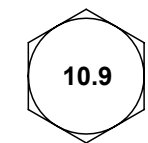

# INSTRUCTIONS FOR 10" BRAKES

## BRAKE INSTALLATION

### 1. Brake Mounting Flange

To assure correct brake action, the mounting flange must be square and concentric with the axle spindle. A flange that is not properly installed will contribute to rapid lining wear and improper brake action.

The 10" DEMCO brake is designed to interchange with existing equipment mounting on flanges with (4) holes on 4" B.C. and a 3" register diameter. Several manufacturers offer complete axles with flanges attached, or you may choose to install flanges yourself.

Two types of cluster plates are used. One with 4" B.C. square pattern for conventional hubs and one with 4" B.C. rectangular pattern for new departure hubs.

Use a flange welding fixture to properly position the flange for welding. Bolt the flange to the welding fixture securely with bolts.

Install the fixture (and flange) onto the spindle and tighten spindle nut. If flange is being installed on a round axle, rotate to insure "wheel cylinder up" location when the axle is installed.

Do not to make a continuous weld around the flange. First, tack weld on all four sides between the bolts. Follow this with a full weld up each side of the axle. It is usually not advisable or necessary to weld across the top and bottom of the axle. The bottom of the axle is its most highly stressed area and a weld at this point will weaken the axle. Allow the axle, spindle, and flange to cool before removing welding fixture.

### 2. Installing Brakes

Place the brake against spindle flange. In mounting the brake, be sure the hydraulic wheel cylinder is at the top. Brakes are also marked as "RIGHTS" and "LEFTS". The brake designated as "LEFT" travels on the driver's side of the road.

**ALWAYS ROTATE DRUM IN DIRECTION OF FORWARD ROTATION ONLY.**

### 3. Installing Brake Drum

When the brakes have been correctly assembled to the axle flanges, the hub and drum assemblies may be mounted on the axle spindle.

Two types of hubs may be used. The new departure hub is greased for life and does not need packing. The conventional hub however is packed as follows.

Pack the inside bearing with suitable wheel bearing grease. Force grease through and around the rollers. Place the bearing in the hub and install the grease seal flush with the end of the hub using an arbor press or soft mallet. Remove excess grease.

To avoid damage to bearing seal, lubricate seal seat prior to putting on the hub. Grease, pack and install the outer bearing on spindle. Place flat washer and spindle nut on spindle. Tighten spindle nut per hub & bearing manufacturing specifications, then install new cotter pin to lock nut and install dust cap.

**Caution:** Do not pack hub full of grease. Excessive grease may leak into brake drums causing brake failure.

Wheels may now be mounted on the trailers.

### 4. Adjusting Brakes

**Non Self adjusting brakes** must be adjusted up and then back off 15-20 clicks. If there is one spot where the wheel drags just slightly this is acceptable.

**Self adjusting brakes** must be adjusted the first time only to assure having brakes the first few times they are applied. Insert a brake adjusting tool or screw driver into the slotted hole. With the handle up and the bit down and against the adjusting nut, pull down on the handle. While spinning the wheel adjust the cog wheel up until you start to get a little brake drag on the wheel. **Do not over tighten the adjusting nut.** You can not back the nut off unless you hold the adjusting shoe away from the nut while turning it back.



## **WARNING: To Prevent Serious Injury or Death**

Saltwater, granular fertilizers and other corrosive materials are destructive to metal. To prolong the life of a braking system used under corrosive conditions, we recommend that the actuator be flushed periodically with a high pressure water hose. Be sure to re-grease bearings and oil all moving parts after the unit has dried. At the end of the season, when unit is to be stored, remove the brake drums and clean inside the brakes. Pack wheel bearings before drum is installed.

### 5. Hydraulic Lines

Use care in forming tubing to avoid sharp bends or kinks. Use double flare steel tubing to assure tight leak-proof connections. Anchor all hydraulic lines at two foot intervals to prevent chafing and vibration. Use hydraulic rubber hose at points of flexing. Anchor hose ends to avoid stress on tubing.

### 6. Bleeding the System

The first requirement for safe, sure hydraulic braking is the use of quality brake fluid. Use only DOT-3 or DOT-4 brake fluid from a sealed container.

#### **Elevate tongue on trailer 4-6 inches**

If pressure bleeding equipment is available, follow the manufacturer's instruction in bleeding the system.

**If system must be bled manually, proceed as follows:** Fill master cylinder with fluid. Install bleeder hose on first wheel cylinder to be bled (if tandem axle trailer,

bleed rear axle first). Have loose end of hose submerged in brake fluid in glass container to observe bubbling.

By loosening the bleeder screw located in the wheel cylinder one turn, the system is open to the atmosphere through the passage drilled in the screw. Pump actuator with short strokes until fluid in master cylinder reservoir stops bubbling, then pump actuator with long steady strokes. The bleeding operation is completed when bubbles no longer rise to the surface of the fluid in glass container. **Be sure to close bleeder screw securely.**

Repeat bleeding operation at each wheel cylinder. During the bleeding process, replenish the brake fluid, so the level does not fall below the 1/2 full level in the master cylinder reservoir. After bleeding is complete, fill the master cylinder reservoir and secure the filler cap.

After the bleeding operation has been completed, apply pressure to the system and check the brake system for leaks.

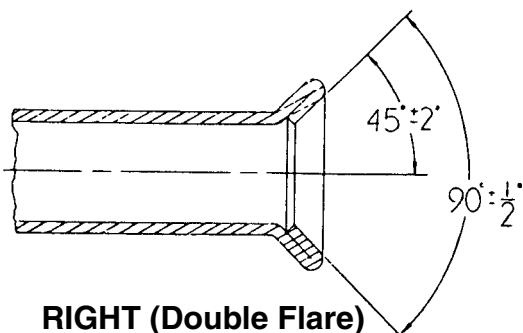
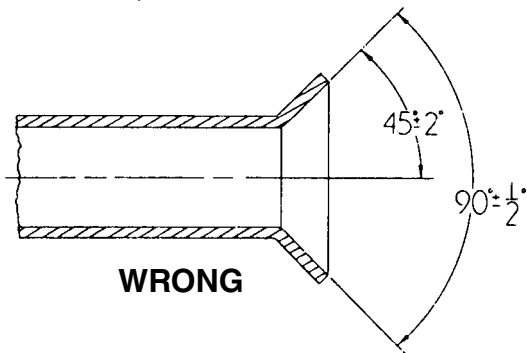

## **WARNING: To Prevent Serious Injury or Death**

**FAILURE TO FOLLOW THESE INSTRUCTIONS, OR FAILURE TO PROPERLY MAINTAIN BRAKES AFTER INSTALLATION, CAN RESULT IN LOSS OF BRAKING ACTION. THIS CAN CAUSE PERSONAL INJURY, DEATH OR PROPERTY DAMAGE. ONLY PROFESSIONAL MECHANICS SHOULD INSTALL BRAKE CLUSTERS. HAVE YOUR BRAKES INSPECTED BY A PROFESSIONAL MECHANIC AT LEAST ANNUALLY AFTER INSTALLATION.**

# 10" STANDARD, MARINE, & NDH FREE BACKING BRAKES

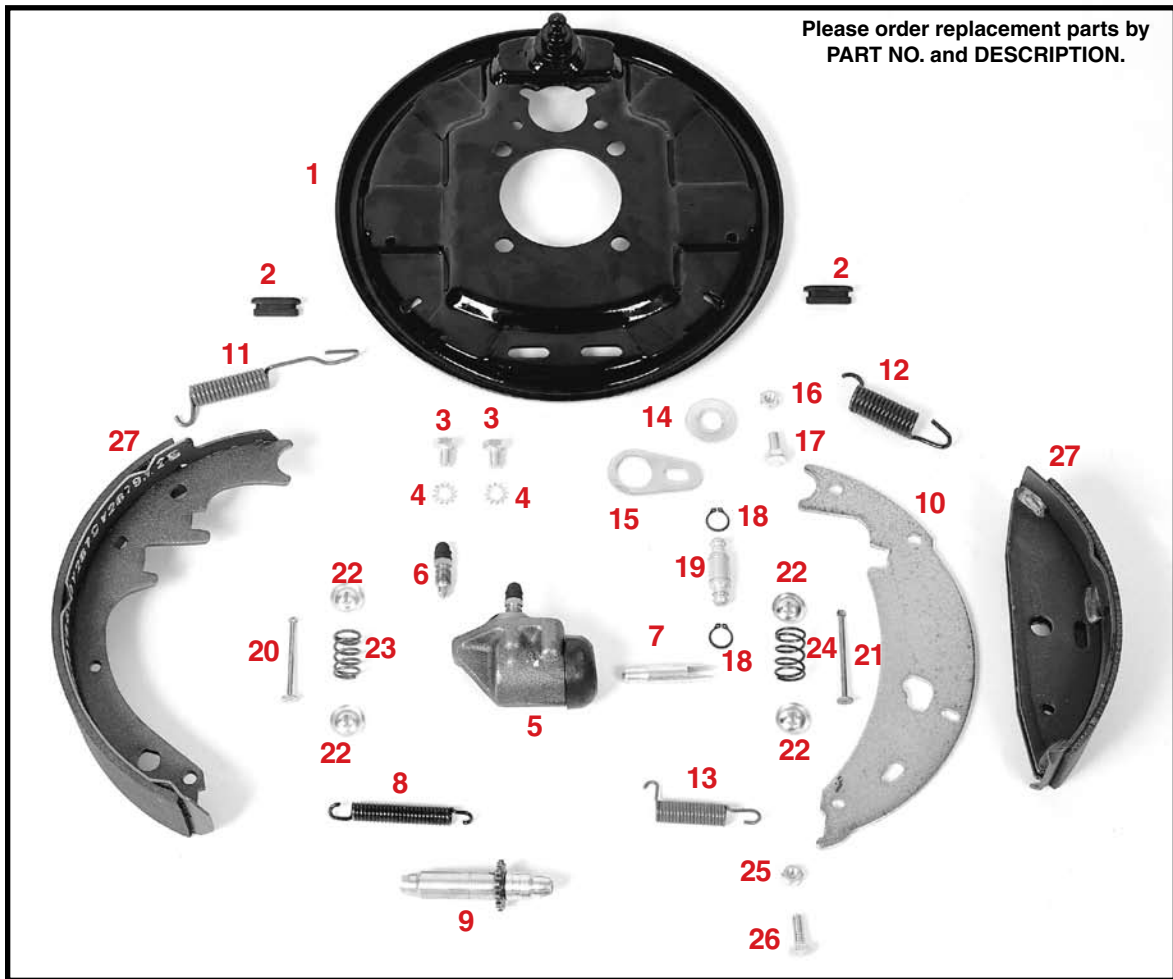

Please order replacement parts by  
PART NO. and DESCRIPTION.

## PARTS LIST for 10" FREE BACKING BRAKES

REF. NO.	PART NO.	QTY.	DESCRIPTION
-	SB40715	-	Right Hand Cluster-Conv. (shown)
-	SB40715M	-	Right Hand Cluster-Conv. MARINE
-	SB19913	-	Right Hand Cluster - NDH
-	SB19913M	-	Right Hand Cluster - NDH MARINE
-	SB40716	-	Left Hand Cluster-Conv.
-	SB40716M	-	Left Hand Cluster-Conv. MARINE
-	SB19914	-	Left Hand Cluster - NDH
-	SB19914M	-	Left Hand Cluster - NDH MARINE
1.	SB24636-30	1	Back Plate Assembly
-	SB23871-30	1	Back Plate Assembly NDH Hub
-	SB24636-96	1	Back Plate Assembly MARINE
-	SB23871-96	1	Back Plate Assembly NDH Hub MARINE
2.	SB9254	2	Cover Plate - Adjusting Hole
3.	04305	2	5/16"-18UNC x 1/2" Hex Hd. Bolt
-	05940	2	5/16"-18UNC x 1/2" Hex Hd. Bolt SS MARINE
4.	05424	2	5/16" External Tooth Washer
-	05941	2	5/16" External Tooth Washer SS MARINE
5.	SB9776	1	Wheel Cylinder Assembly -Right
-	SB9776M	1	Wheel Cylinder Assembly-Right MARINE
-	SB9777	1	Wheel Cylinder Assembly - Left
-	SB9777M	1	Wheel Cylinder Assembly-Left MARINE
-	SB15845	1	Repair Kit - Wheel Cylinder (includes spring, cup and boot)
6.	05431	1	Bleeder - replacement
7.	SB9783	1	Push Rod
-	SB9783M	1	Push Rod MARINE Olive Drab
8.	SB10957	1	Spring-Adjusting Screw
-	SB10957M	1	Spring-Adjusting Screw SS MARINE
9.	SB05431	1	Adjusting Screw Assembly

REF. NO.	PART NO.	QTY.	DESCRIPTION
10.	SB17916-95	1	Shoe Lever
11.	SB10958	1	Spring - Shoe
-	SB10958M	1	Spring-Shoe MARINE
12.	SB9785	1	Spring Lever
-	SB9785M	1	Spring Lever MARINE
13.	SB6814	2	Spring-Shoe
-	SB6814M	2	Spring-Shoe MARINE
14.	00205	1	Washer-Shoe Guide
15.	SB17917-95	1	Travel Link
16.	05962	1	5/16"-18 UNC Locknut
-	05942	1	5/16"-18 UNC Locknut SS MARINE
17.	05961	1	5/16"-18UNC x 5/8" Hex Hd. Bolt
-	05943	1	5/16"-18UNC x 5/8" Hex Hd. Bolt SS MARINE
18.	SB7778	1	Retaining Ring
-	SB7778M	1	Retaining Ring SS MARINE
19.	05824	1	Pin-Front Shoe
20.	SB10959	1	Pin - Shoe Hold Down #8
21.	03562	1	Pin - Shoe Hold Down #1
22.	SB9789	4	Cup Shoe Hold Down
23.	05983	2	Spring - Shoe Hold Down Blue
-	07884	1	Spring- Shoe Hold Down SS MARINE
24.	SB9790	1	Spring - Shoe Hold Down Maroon
-	07883	1	Spring- Shoe Hold Down SS MARINE
25.	05963	1	1/4"-20UNC Locknut
-	05944	1	1/4"-20UNC Locknut SS MARINE
26.	01076	1	1/4"-20UNC x 3/4" Hex Hd. Bolt
-	05930	1	1/4"-20UNC x 3/4" Hex Hd. Bolt SS MARINE
27.	SB10955	1	Brake Shoe Kit (2 front & 2 rear)
-	07812	1	Brake Shoe Kit (2 front & 2 rear) MARINE

# 10" STANDARD, MARINE, & NDH UNI-SERVO BRAKES

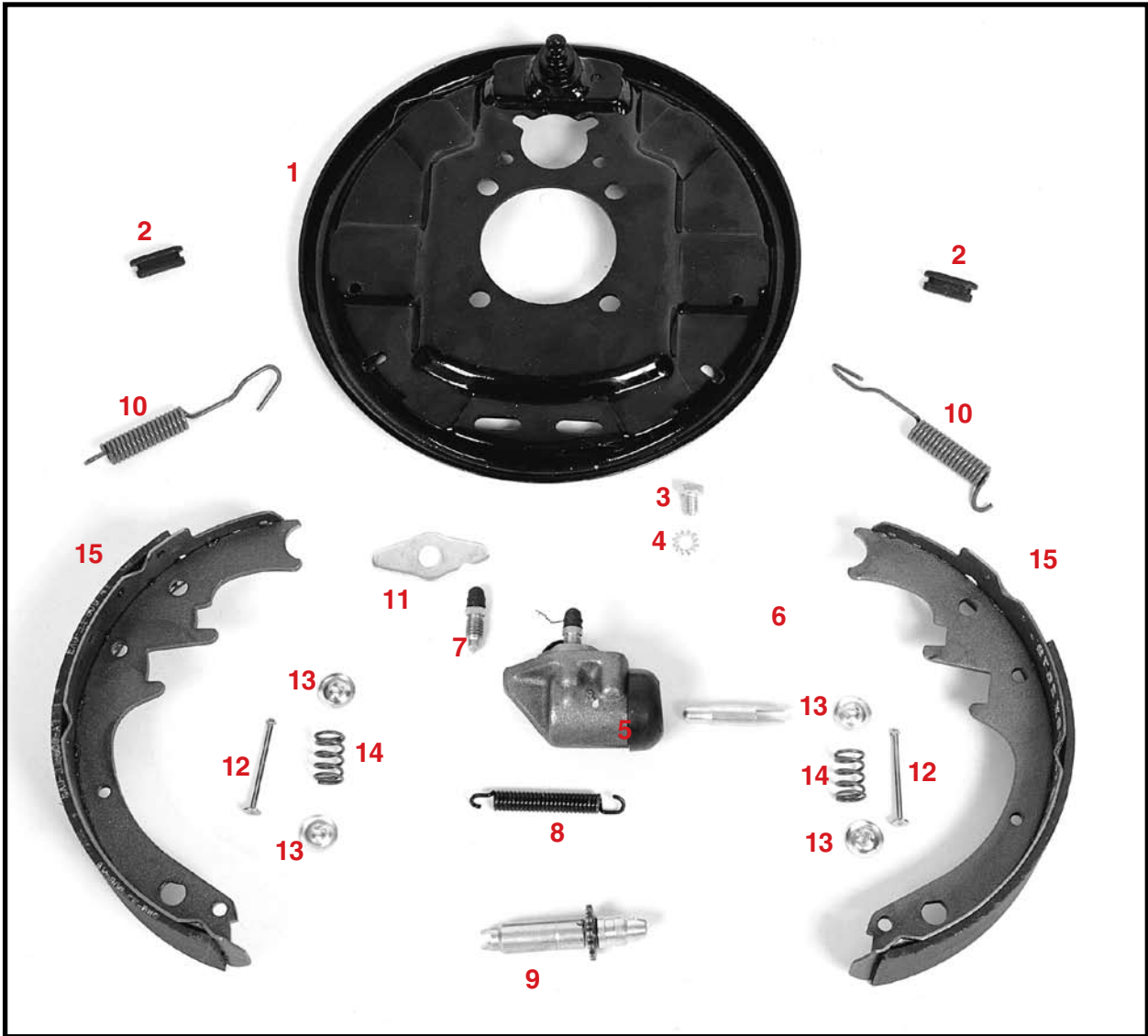

## PARTS LIST for 10"UNI-SERVO BRAKES

REF. NO.	PART NO.	QTY.	DESCRIPTION
-	SB18787	-	Right Hand Cluster-Conv. (shown)
-	SB18787M	-	Right Hand Cluster-Conv. MARINE
-	SB19915	-	Right Hand Cluster - NDH
-	SB19915M	-	Right Hand Cluster - NDH MARINE
-	SB18788	-	Left Hand Cluster-Conv.
-	SB18788M	-	Left Hand Cluster-Conv. MARINE
-	SB19916	-	Left Hand Cluster - NDH
-	SB19916M	-	Left Hand Cluster - NDH MARINE
1.	SB24636-30	1	Back Plate Assembly
-	SB24636-96	1	Back Plate Assembly MARINE
-	SB23871-30	1	Back Plate Assembly NDH HUB
-	SB23871-96	1	Back Plate Assembly NDH HUB MARINE
2.	SB9254	2	Cover Plate - Adjusting Hole
3.	04305	2	5/16"-18UNC x 1/2" Hex Hd. Bolt
-	05940	2	5/16"-18UNC x 1/2" Hex Hd. Bolt SS MARINE
4.	05424	2	5/16" External Tooth Washer
-	05941	2	5/16" External Tooth Washer SS MARINE
5.	SB9776	1	Wheel Cylinder Assembly -Right
-	SB9776M	1	Wheel Cylinder Assembly-Right MARINE
-	SB9777	1	Wheel Cylinder Assembly - Left
-	SB9777M	1	Wheel Cylinder Assembly-Left MARINE
-	SB15845	1	Repair Kit - Wheel Cylinder (includes spring, cup and boot)

REF. NO.	PART NO.	QTY.	DESCRIPTION
6.	05431	1	Bleeder - replacement
7.	SB9783	1	Push Rod
-	SB9783M	1	Push Rod MARINE Olive Drab
8.	SB10957	1	Spring-Adjusting Screw
-	SB10957M	1	Spring-Adjusting Screw SS MARINE
9.	SB05431	1	Adjusting Screw Assembly
10.	SB10958	2	Spring - Shoe
-	SB10958M	2	Spring-Shoe MARINE
11.	SB10961-95	1	Shoe Guide
12.	SB10959	2	Pin - Shoe Hold Down
13.	SB9789	4	Cup Shoe Hold Down
14.	05983	2	Spring - Shoe Hold Down Blue
-	07884	2	Spring- Shoe Hold Down SS MARINE
15.	SB10954	1	Brake Shoe Kit (2 front & 2 rear)
-	07811	1	Brake Shoe Kit (2 front & 2 rear) MARINE

Please order replacement parts by PART NO. and DESCRIPTION.



## 10" STANDARD & NDH DUO-SERVO BRAKES

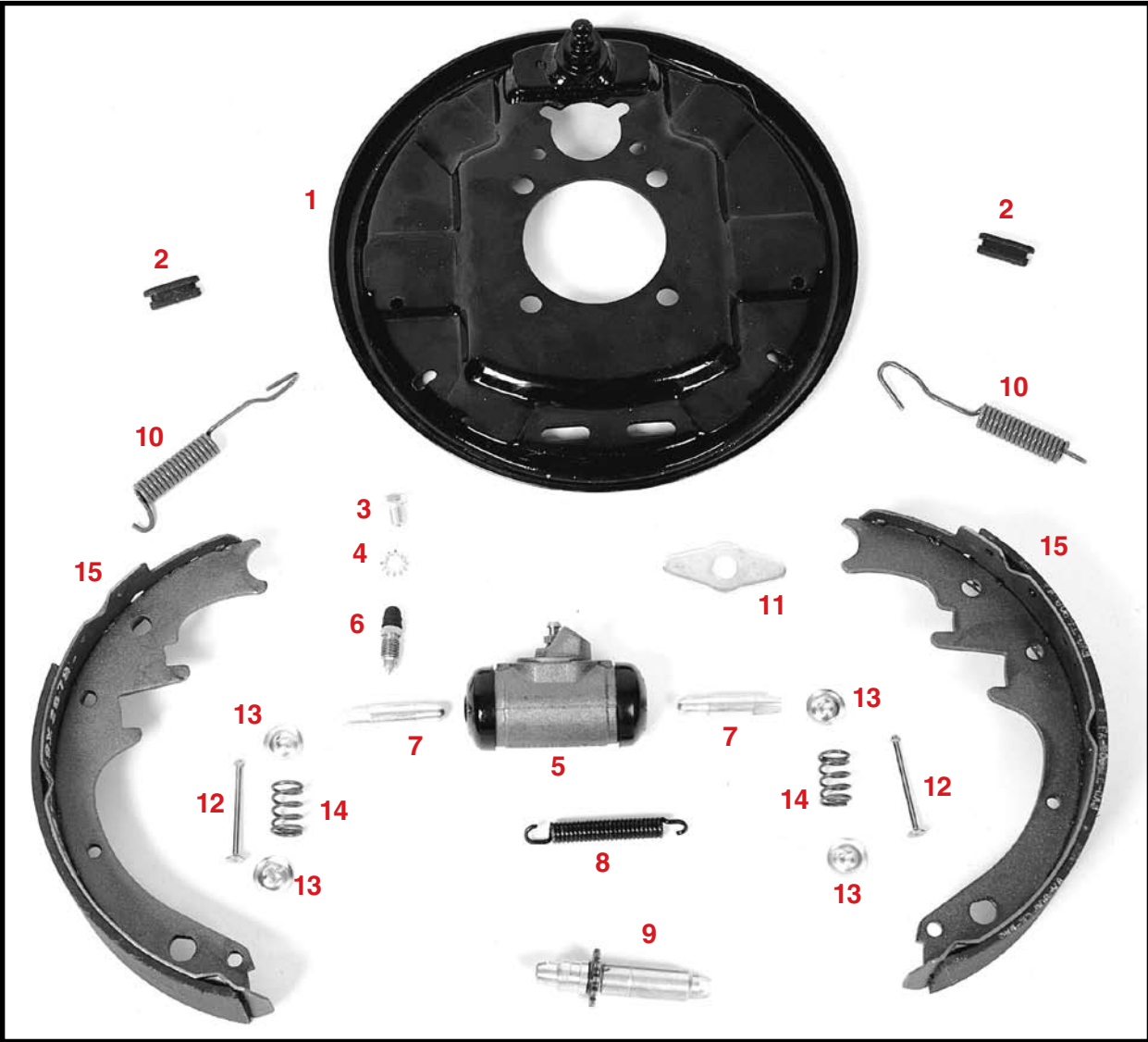

### PARTS LIST for 10"DUO-SERVO BRAKES

REF. NO.	PART NO.	QTY.	DESCRIPTION
-	SB18793	-	Right Hand Cluster-Conv.
-	SB19911	-	Right Hand Cluster - NDH
-	SB18794	-	Left Hand Cluster-Conv. (shown)
-	SB19912	-	Left Hand Cluster - NDH
1.	SB24636-30	1	Back Plate Assembly
-	SB23871-30	1	NDH Hub Back Plate Assembly
2.	SB9254	2	Cover Plate - Adjusting Hole
3.	04305	2	5/16"-18UNC x 1/2" Hex Hd. Bolt
4.	05424	2	5/16" External Tooth Washer
5.	SB17185	1	Wheel Cylinder Assembly -Right
-	SB17186	1	Wheel Cylinder Assembly - Left
-	SB15845	1	Repair Kit - Wheel Cylinder (includes spring, cup and boot)
6.	05431	1	Bleeder - replacement
7.	SB9783	2	Push Rod
8.	SB10957	1	Spring-Adjusting Screw

REF. NO.	PART NO.	QTY.	DESCRIPTION
9.	SB05431	1	Adjusting Screw Assembly
10.	SB10958	2	Spring - Shoe
11.	SB10961-95	1	Shoe Guide
12.	SB10959	2	Pin - Shoe Hold Down #8
13.	SB9789	4	Cup Shoe Hold Down
14.	05983	2	Spring - Shoe Hold Down <b>Blue</b>
15.	SB10954	1	Brake Shoe Kit (2 front & 2 rear)

Please order replacement parts by **PART NO.** and **DESCRIPTION.**

## 10" STANDARD & NDH SELF ADJUSTING BRAKES

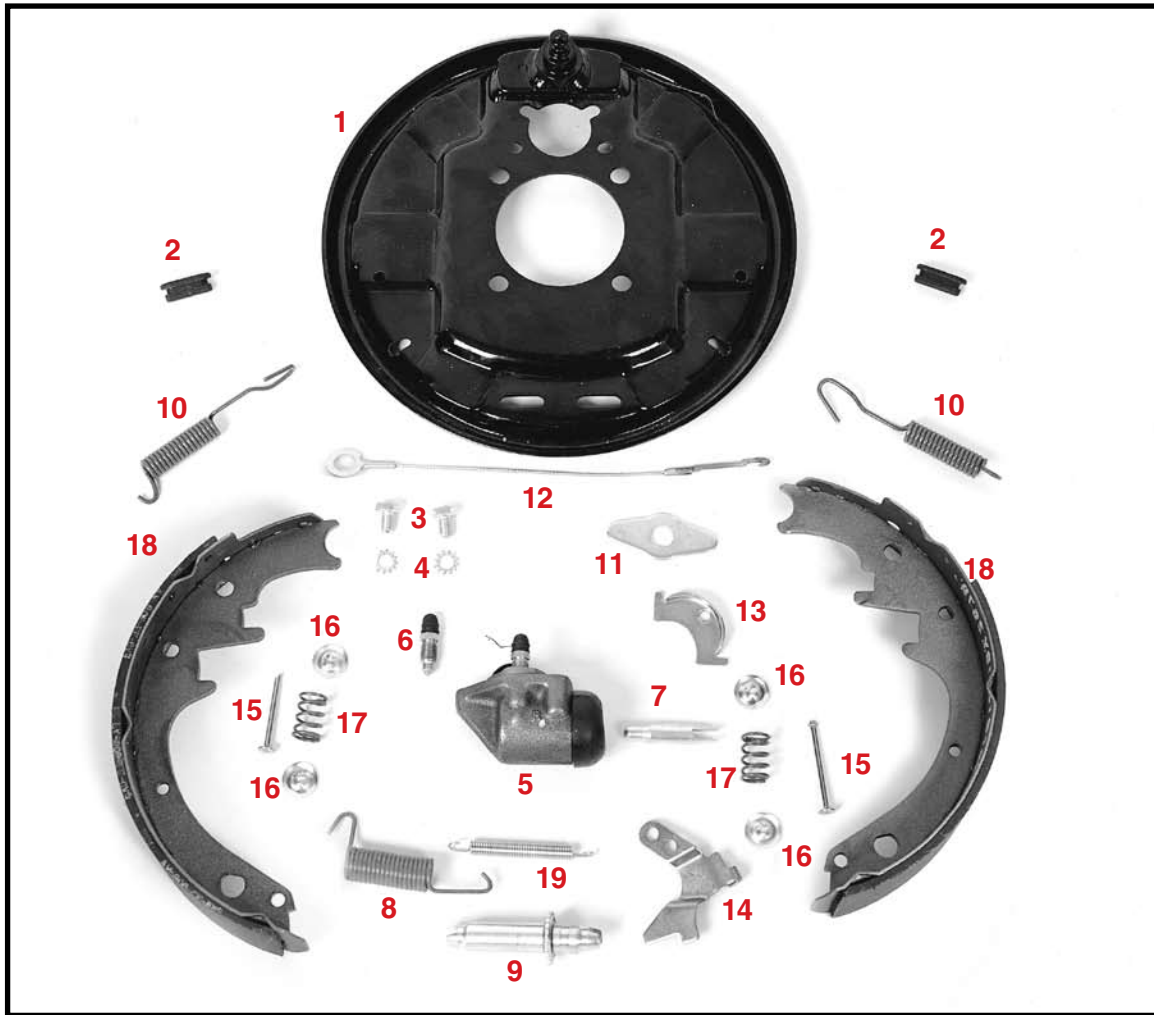

### PARTS LIST for 10" SELF ADJUSTING BRAKES

REF. NO.	PART NO.	QTY.	DESCRIPTION
-	SB23714	-	Right Hand Cluster-Conv. (shown)
-	SB24428	-	Right Hand Cluster - NDH
-	SB23715	-	Left Hand Cluster-Conv.
-	SB24429	-	Left Hand Cluster - NDH
1.	SB24636-30	1	Back Plate Assembly
-	SB23871-30	1	NDH Hub Back Plate Assembly
2.	SB9254	2	Cover Plate - Adjusting Hole
3.	04305	2	5/16"-18UNC x 1/2" Hex Hd. Bolt
4.	05424	2	5/16" External Tooth Washer
5.	SB9776	1	Wheel Cylinder Assembly -Right
-	SB9777	1	Wheel Cylinder Assembly - Left
-	SB15845	1	<b>Repair Kit - Wheel Cylinder</b> (includes spring, cup and boot)
6.	05431	1	Bleeder - replacement
7.	SB9783	1	Push Rod
8.	SB23724	1	Spring-Adjusting Screw
9.	SB24047	1	Adjusting Screw Assembly-Left "R"
-	SB24048	1	Adjusting Screw Assembly-Right "L"
10.	SB10958	2	Spring - Shoe
11.	SB10961-95	1	Shoe Guide
12.	SB23937	1	Cable
13.	SB23936	1	Cable Guide

REF. NO.	PART NO.	QTY.	DESCRIPTION
14.	05415-95	1	Lever-Right (shown)*
-	05414-95	1	Lever-Left*
15.	SB10959	2	Pin - Shoe Hold Down
16.	SB9789	4	Cup Shoe Hold Down
17.	05983	2	Spring - Shoe Hold Down <b>Blue</b>
18.	SB10954	1	Brake Shoe Kit (2 front & 2 rear)
19.	03880	1	Spring-Adjusting Screw Retainer

Please order replacement parts by **PART NO.** and **DESCRIPTION.**  
\* Patent Pending.



P.O. BOX 189  
4010 320th St., BOYDEN, IA. 51234  
PH: (712) 725-2311 or (712) 725-2302  
FAX: (712) 725-2380  
TOLL FREE: 1-800-54DEMCO (1-800-543-3626)  
[www.demco-products.com](http://www.demco-products.com)