



5/17
HJ26004, Rev 5



5th Wheel Side Rail Assemblies

6004 UMS SIDE RAIL

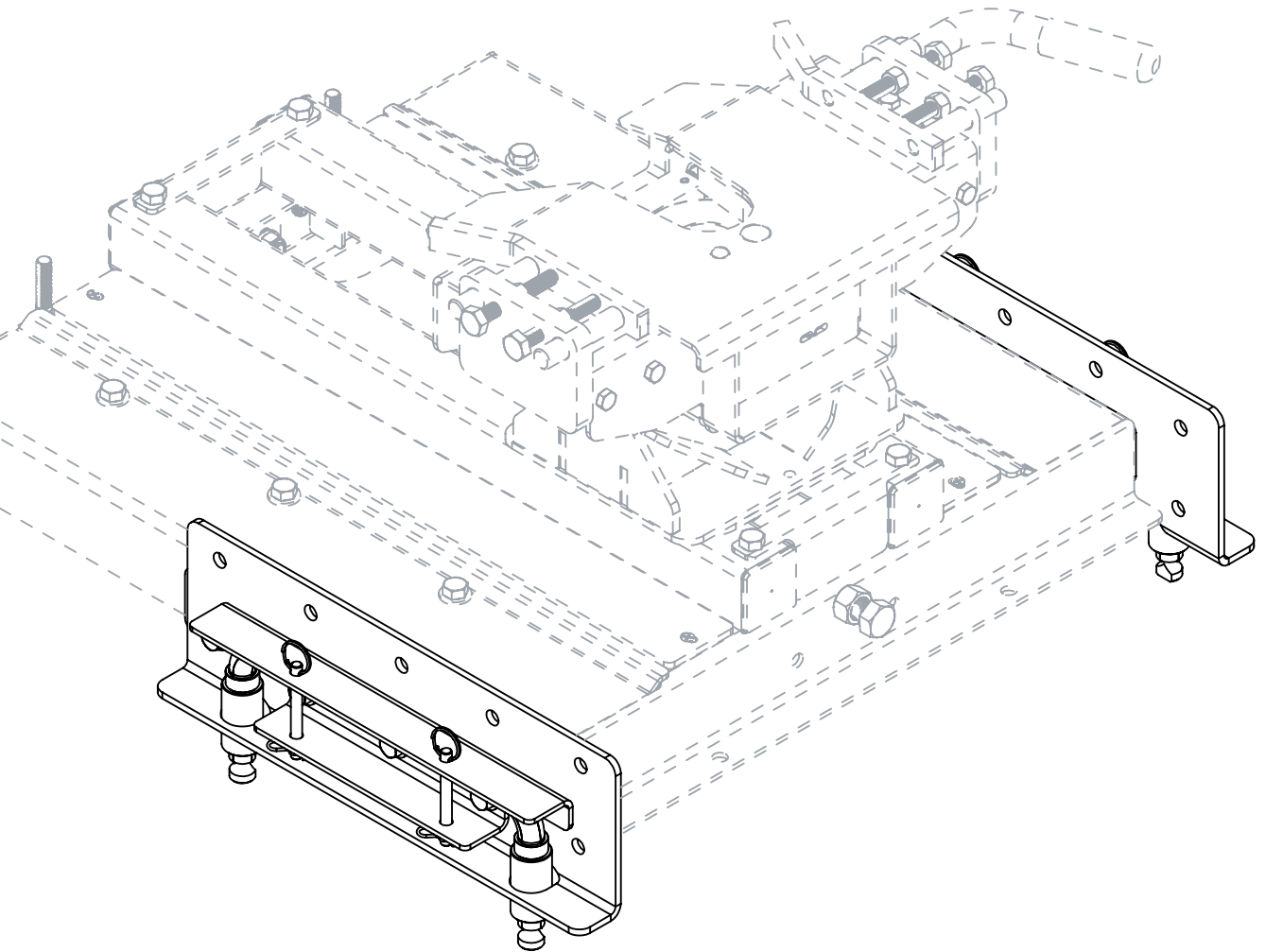

READ *complete manual CAREFULLY*
BEFORE attempting operation.

Doing Our Best to Provide You the Best

MANUAL
OPERATORS

WARRANTY POLICY, OPERATOR MANUALS & REGISTRATION

Go online to www.demco-products.com to review Demco warranty policies, operator manuals and register your Demco product.

Please consult vehicle owners manual for 5th wheel towing instructions.



Torque Specifications

BOLT TORQUE DATA FOR STANDARD NUTS, BOLTS, AND CAPSCREWS.

Tighten all bolts to torques specified in chart unless otherwise noted. Check tightness of bolts periodically, using bolt chart as guide. Replace hardware with same grade bolt.

NOTE: Unless otherwise specified, high-strength Grade 5 hex bolts are used throughout assembly of equipment.

Torque figures indicated are valid for non-greased or non-oiled threads and heads unless otherwise specified. Therefore, do not grease or oil bolts or capscrews unless otherwise specified in this manual. When using locking elements, increase torque values by 5%.

* GRADE or CLASS value for bolts and capscrews are identified by their head markings.

Bolt Torque for Standard bolts *

"A"	GRADE 2		GRADE 5		GRADE 8	
	lb-ft	(N.m)	lb-ft	(N.m)	lb-ft	(N.m)
1/4"	6	(8)	9	(12)	12	(16)
5/16"	10	(13)	18	(25)	25	(35)
3/8"	20	(27)	30	(40)	45	(60)
7/16"	30	(40)	50	(70)	80	(110)
1/2"	45	(60)	75	(100)	115	(155)
9/16"	70	(95)	115	(155)	165	(220)
5/8"	95	(130)	150	(200)	225	(300)
3/4"	165	(225)	290	(390)	400	(540)
7/8"	170	(230)	420	(570)	650	(880)
1"	225	(300)	630	(850)	970	(1310)

Bolt Torque for Metric bolts *

"A"	CLASS 8.8		CLASS 9.8		CLASS 10.9	
	lb-ft	(N.m)	lb-ft	(N.m)	lb-ft	(N.m)
6	9	(13)	10	(14)	13	(17)
7	15	(21)	18	(24)	21	(29)
8	23	(31)	25	(34)	31	(42)
10	45	(61)	50	(68)	61	(83)
12	78	(106)	88	(118)	106	(144)
14	125	(169)	140	(189)	170	(230)
16	194	(263)	216	(293)	263	(357)
18	268	(363)	--	--	364	(493)
20	378	(513)	--	--	515	(689)
22	516	(699)	--	--	702	(952)
24	654	(886)	--	--	890	(1206)

6004 Side Rail Assembly Instructions

1. Loosely bolt the main Autoslide assembly to the side rails with spacer plates using the 1/2" x 1 3/4" bolts, flat washers, and lock nuts provided in the side rail bolt package at the predetermined height using the bolt pattern guide below. **NOTE:** On highest setting, use 6 bolts. The 4 along the top row are to fasten to hitch assembly and the bottom 2 are to fasten the side rail brace to side rail to retain locking pins. (1/4" & 3/8" thick spacers are supplied for adjusting the hitch mount width with the bed pockets. You may mix and match the different shim thicknesses for fine tuning the fit).
2. Tighten all bolts.
3. Unlock locking pins and insert the hitch assembly into the base rails and test for fit. If the pins are too narrow to drop in, follow the alignment procedure on page 3.
4. Proceed to base rail install procedure as provided in the base rail installation kit.

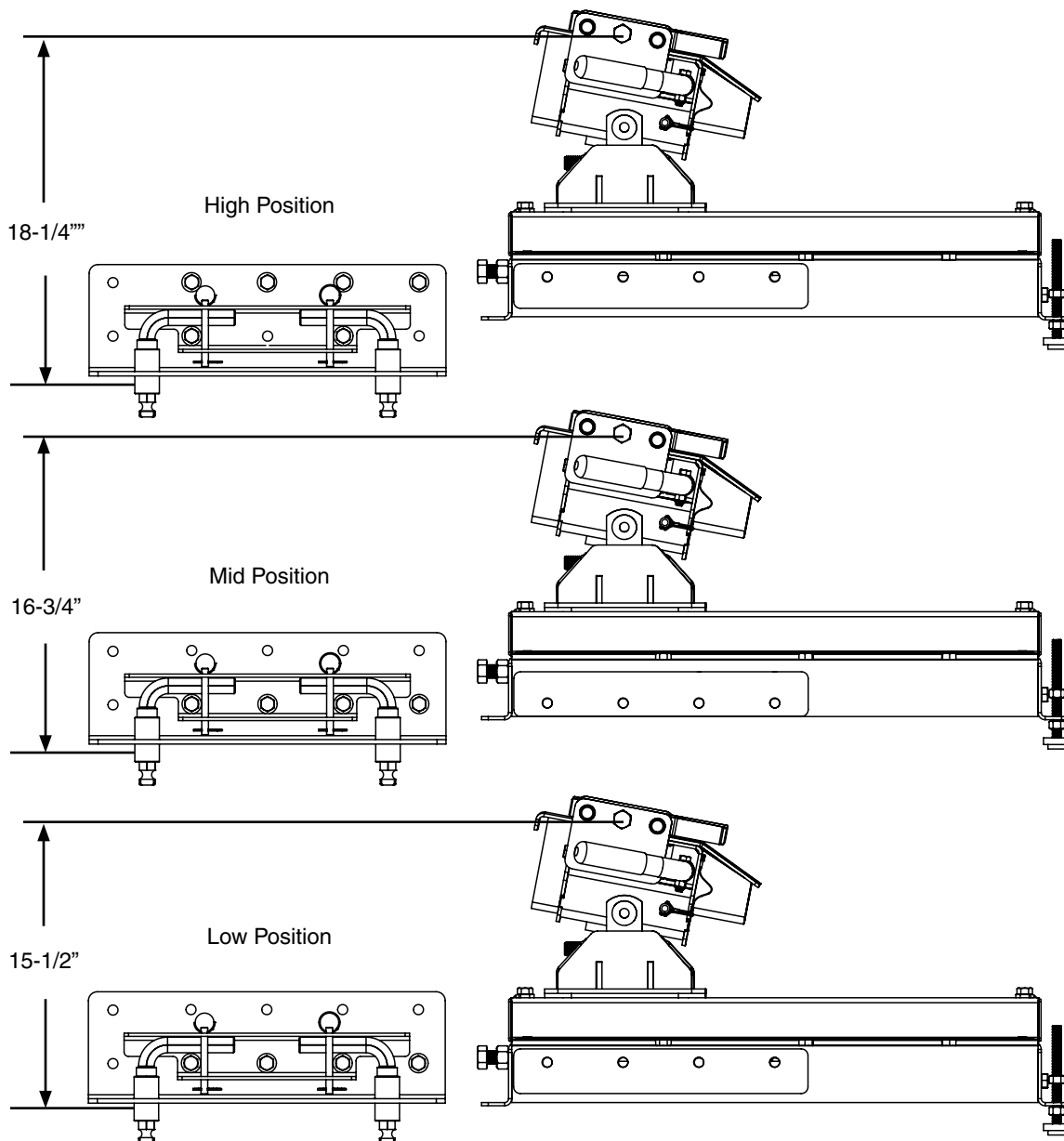

6004 Parts Breakdown

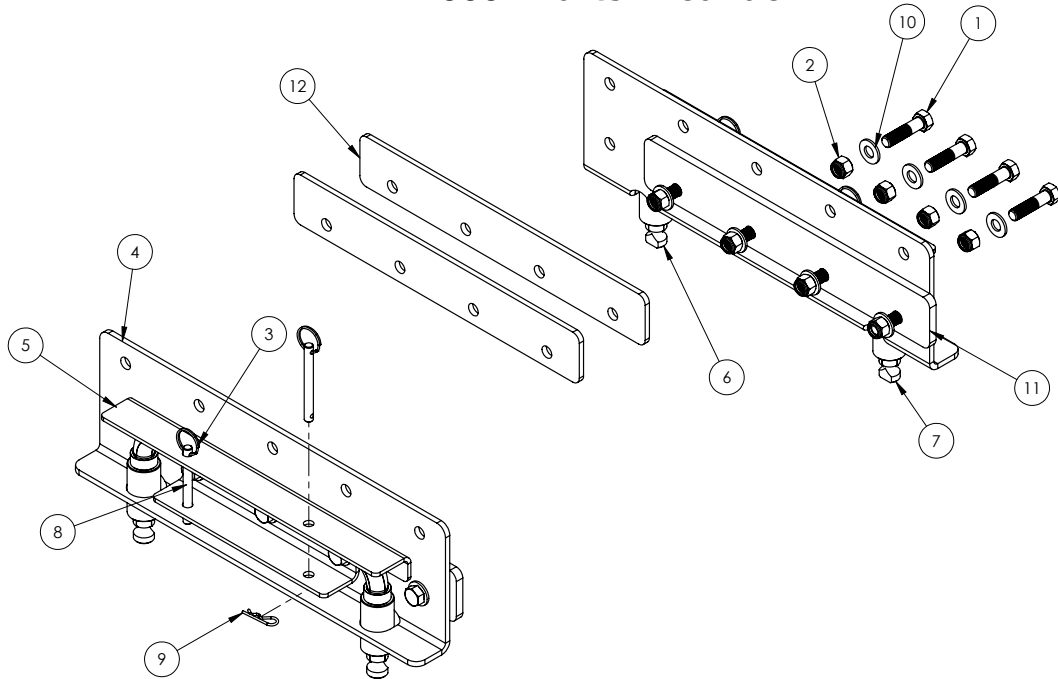

ITEM	PART #	QTY	DESCRIPTION
1	01253	12	BOLT, .50 NC x 2.00 GR.5 HEX
2	02178	12	NUT, .50NC LOCK, NY. INSERT
3	07225	4	SPLIT RING
4	14260-76	2	UMS SIDE RAIL
5	14262-76	2	UMS SIDE RAIL BRACE
6	14263-95	2	UMS LOCK PIN ASSEMBLY, PASSENGER FRONT/DRIVER REAR
7	14264-95	2	UMS LOCK PIN ASSEMBLY, PASSENGER REAR/DRIVER FRONT
8	14342-95	4	CLEVIS SAFETY PIN
9	14350	4	HAIR PIN, .093 WIRE X 1.63 OL
10	14488	20	.50 FLAT WASHER
11	14763-76	2	.375 AS SPACER
12	14959-76	2	.25 AS SPACER

Please order replacement parts by PART NO. and DESCRIPTION

IMPORTANT NOTE: Apply a little grease or lubricant to the part of the pins that insert into the base rails to help maintain smooth operation and rotation of pins and to protect from the elements. Turn the pins occasionally to prevent them from seizing.

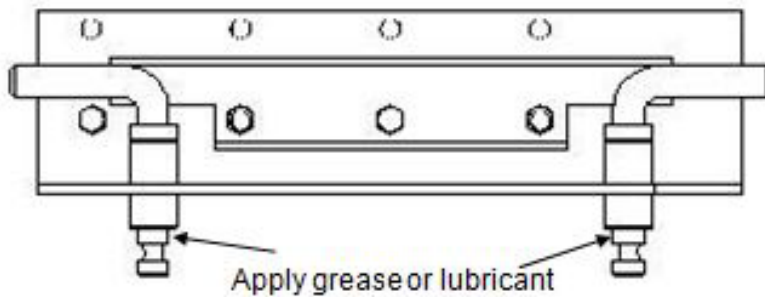

Alignment Procedure

If the side plate pins do not drop into the base rail holes because they are not out far enough, then undo one side and add a 1/2" flat washer in between the main frame and the side spacer plate at each bolt attachments hole. Tighten and try reinstalling into the base rails. If necessary, do the same on the other side to shim out further if needed.

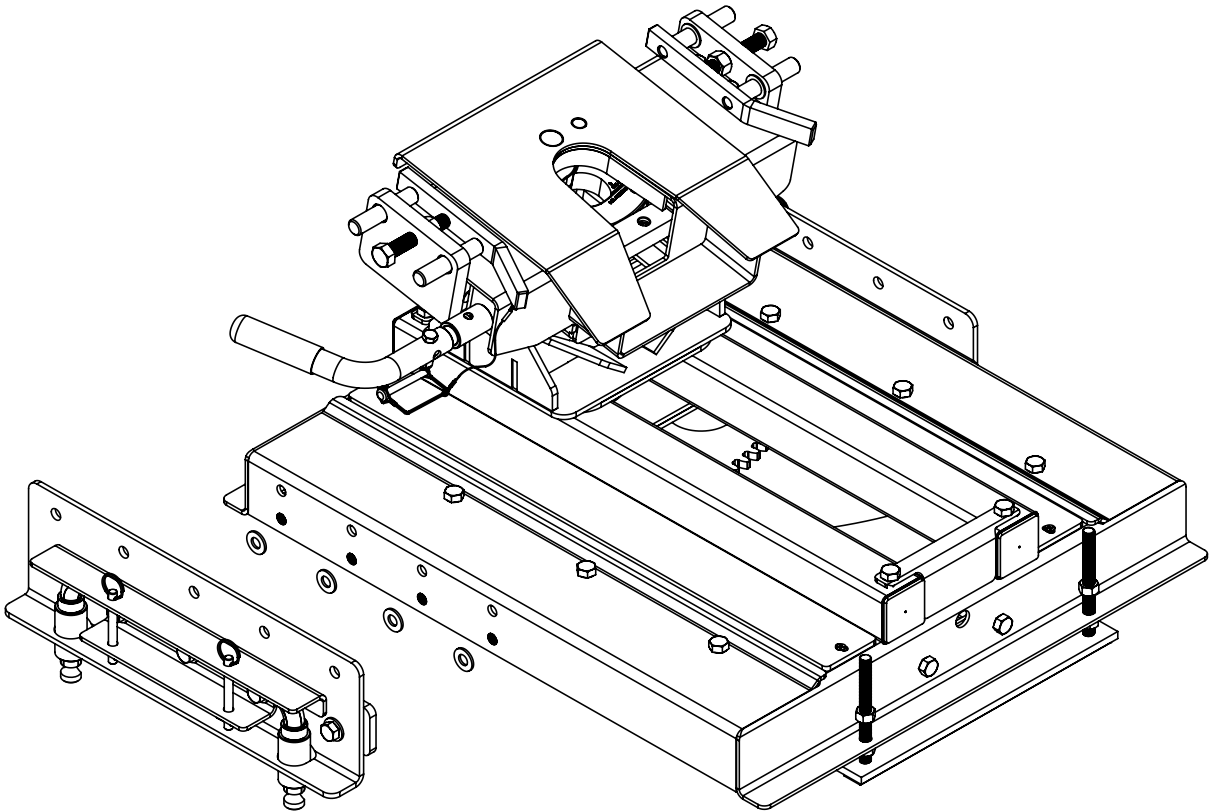

NOTES

NOTES



4010 320th St., BOYDEN, IA. 51234

PH: (712) 725-2311

FAX: (712) 725-2380

TOLL FREE: 1-800-54DEMCO (1-800-543-3626)

www.demco-products.com

Go online to www.demco-products.com for Demco warranty policies, operator manuals & product registration.