

4/16
HJ26040 rev 2

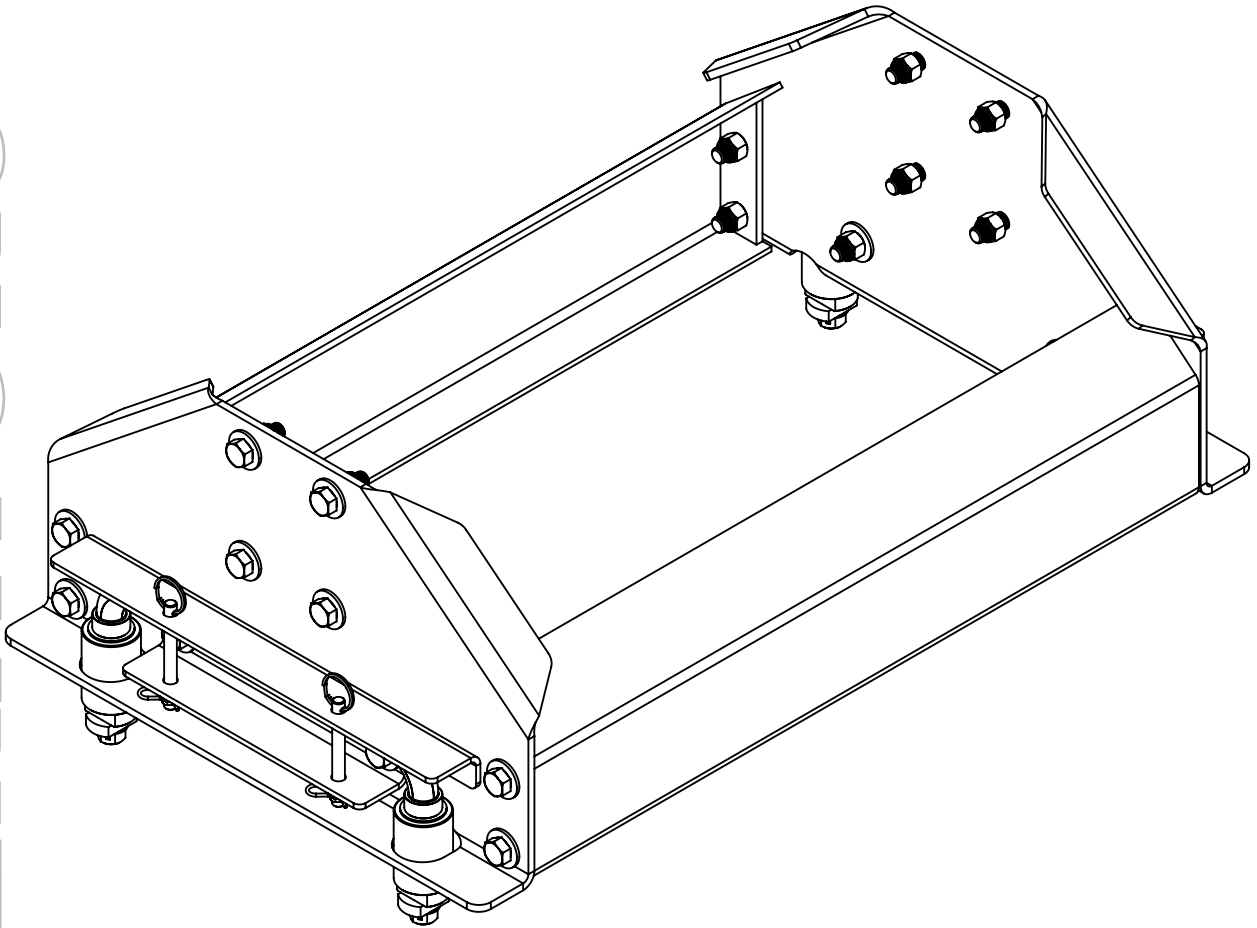

5th Wheel Side Rail Assemblies

6040 Reese UMS SIDE RAIL



READ *complete manual CAREFULLY*
BEFORE attempting operation.

Doing Our Best to Provide You the Best

MANUAL
OPERATORS

WARRANTY POLICY, OPERATOR MANUALS & REGISTRATION

Go online to www.demco-products.com to review Demco warranty policies, operator manuals and register your Demco product.

6040 UMS Side Rail Assembly Instructions

1. Place the side rail plates into the base rail holes in truck box.
2. Loosely bolt the saddle bracket (5990) to the side rails using the 1/2" x 1 1/2" bolts, flat washers, and lock nuts provided in the 6040 bolt package.
3. Loosely bolt the cross braces to the side rails using only 1/2" x 1 1/2" bolts and lock nuts (no flat washers). NOTE: A flat washer under the head of the bolts would prevent the locking pins from pivoting around far enough to allow the pins to release from the base rails.
4. Tighten all the bolts.
5. Unlock and remove the hitch assembly from the base rails and put to the side for later.

IMPORTANT NOTE: Apply a little grease or lubricant to the part of the pins that insert into the base rails to help maintain smooth operation and rotation of pins and to protect from the elements. Turn the pins occasionally to prevent them from seizing.

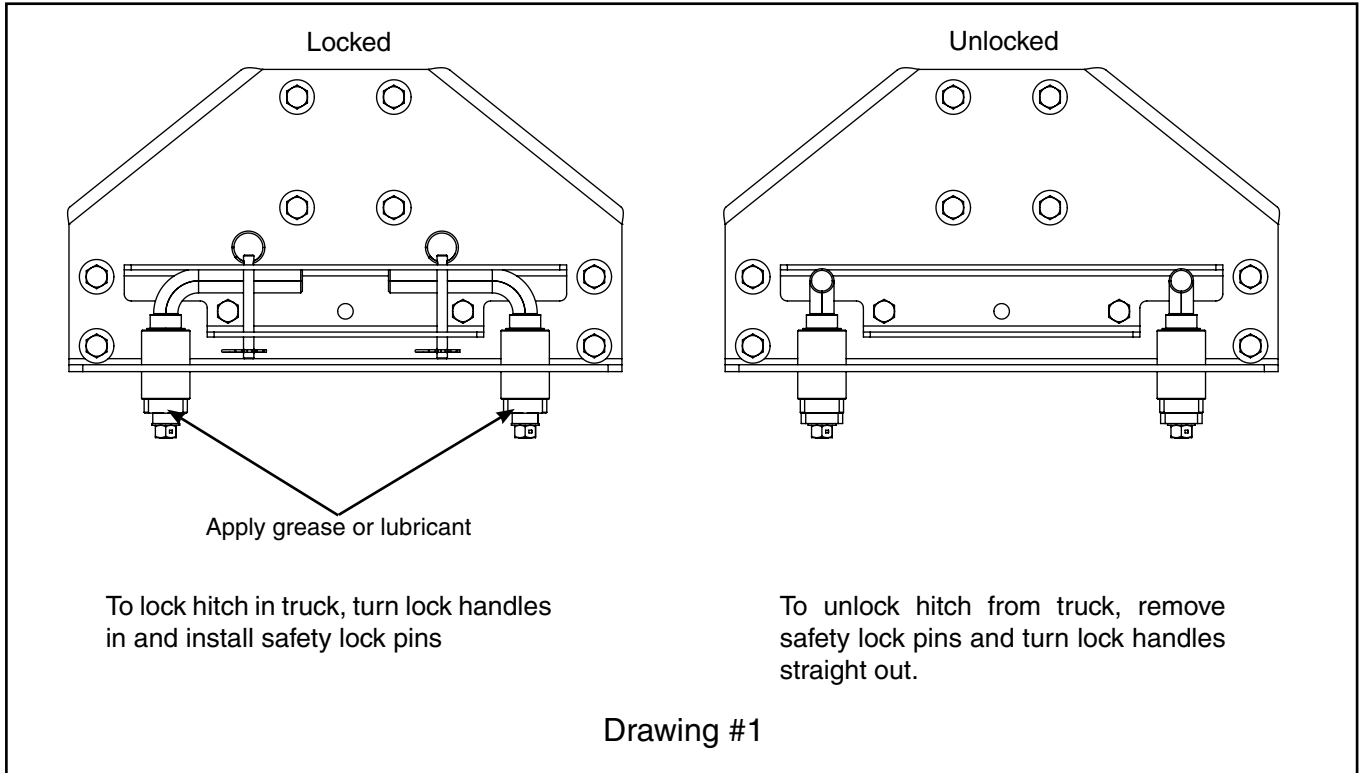

6040 Parts Breakdown

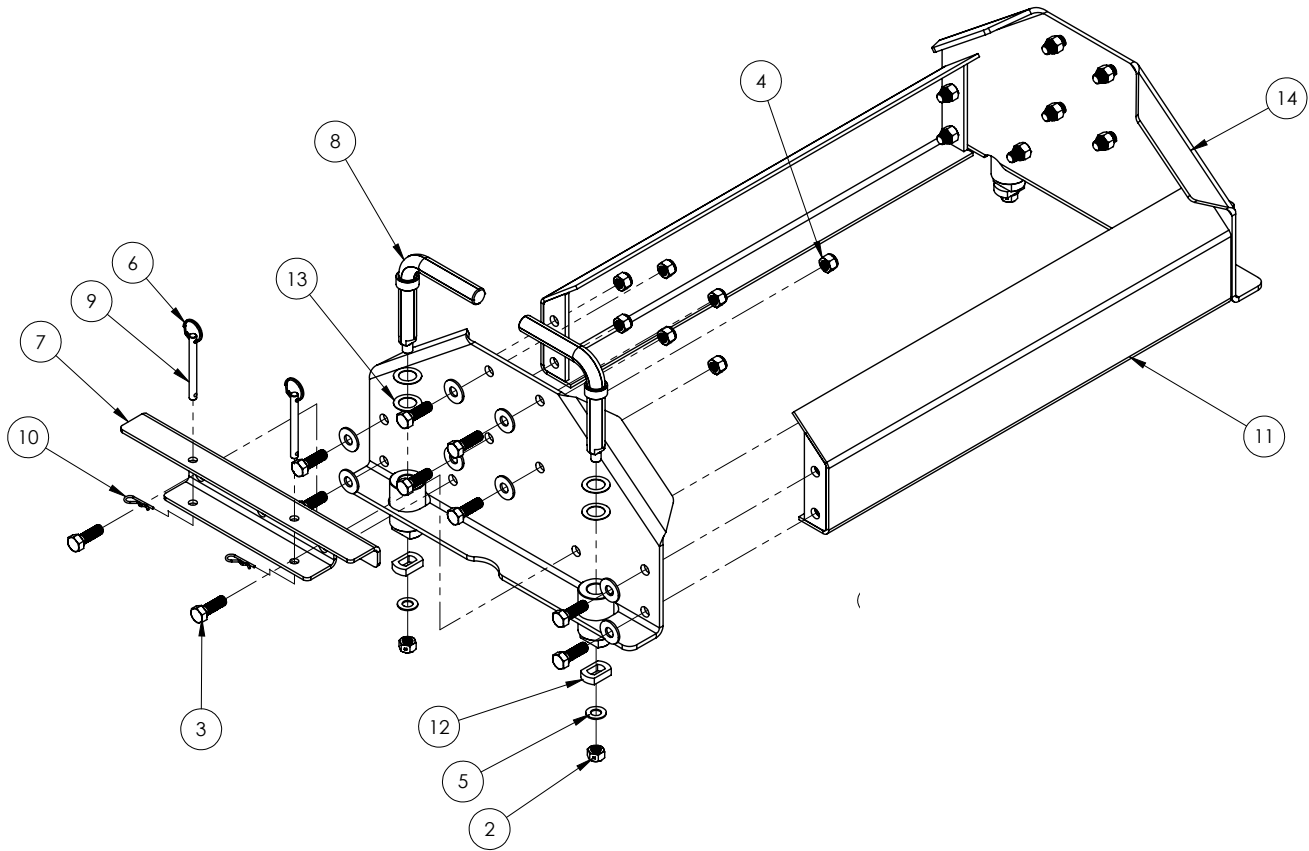

6040 Parts Breakdown

ITEM	PART #	QTY	DESCRIPTION
1	00085	16	.50 FLAT WASHER
2	00173	4	NUT, HEX, .50NC CENTER PUNCH
3	01254	20	BOLT, .50 NC X 1.50 GR.5 HEX
4	02178	20	NUT, .50NC LOCK, NY. INSERT
5	02384	4	.50 X 14GA MACHINE WASHER
6	07225	4	SPLIT RING
7	14262-76	2	UMS SIDE RAIL BRACE
8	14412-95	4	UMS LOCK PIN ASSEMBLY, REESE
9	14342-95	4	CLEVIS SAFETY PIN
10	14350	4	HAIR PIN, .093 WIRE X 1.63 OL
11	14352-76	2	UMS 21K BRACE
12	14413-95	4	LOCKING TAB
13	14423	8	WASHER SHIM .875 ID X .030 THK
14	14462-76	2	SIDE RAIL F/UM REESE MNT

Please order replacement parts by PART NO. and DESCRIPTION.

Demco

4010 320th St., BOYDEN, IA. 51234

PH: (712) 725-2311

FAX: (712) 725-2380

TOLL FREE: 1-800-54DEMCO (1-800-543-3626)

www.demco-products.com

Go online to www.demco-products.com for Demco warranty policies, operator manuals & product registration.