

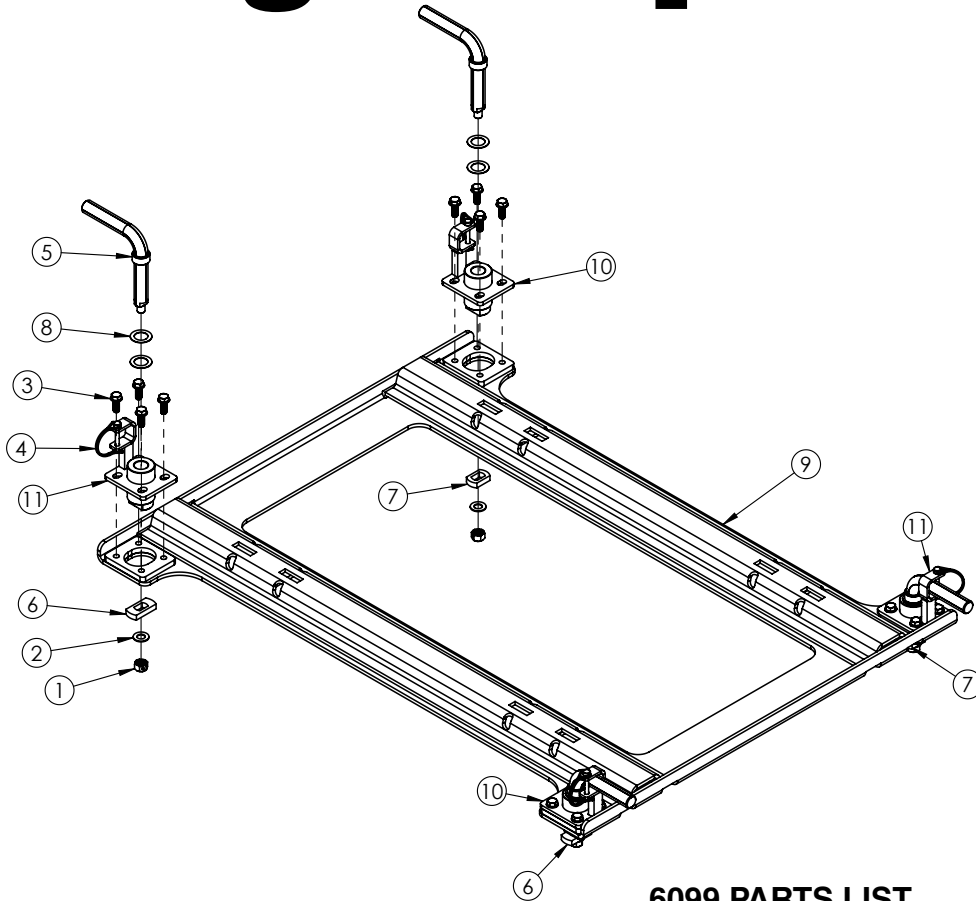

Dodge Prep Rails UL



6099 PARTS LIST

REF. NO.	PART NO.	QTY.	DESCRIPTION
1.	00173	4	.5 NC Hex Nut Center Punch
2.	02384	4	.5 x 14GA Machine Washer
3.	14930	16	Bolt .375 NC x 1.00 GR5 Hex w/srtd flng
4.	11790	4	.25 x 2.00 Pin W/ Wire Clip
5.	14412-95	4	UMS Lock Pin
6.	14914-91	2	Locking Tab Large Gold
7.	14413-95	2	Locking Tab Small Silver
8.	14423	8	Washer Shim .875 ID x .030 THK
9.	14915-76	1	Main Frame
10.	14916-76	2	Locking Socket Driver Front Pass. Rear
11.	14929-76	2	Locking Socket Pass. Front Driver Rear

Please order replacement parts by PART NO. and DESCRIPTION.

READ complete manual CAREFULLY
BEFORE attempting operation.



1. Remove covers from each mounting pod and place main frame into box of truck over mounting pods as shown.

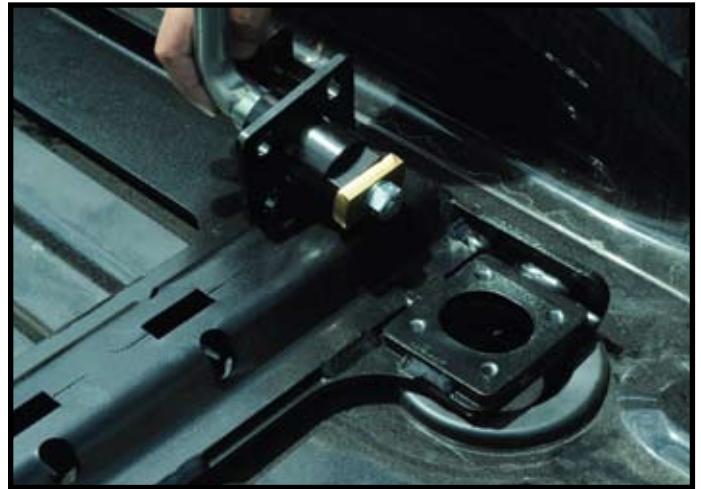

3. Place rear locking sockets (gold locking tabs) into main frame and lock. Insert four 3/8" x 1.00" flanged head bolts to each socket and leave loose. Reference front drawing for direction of locking sockets.



2. Place front locking sockets (silver locking tabs) into main frame and lock. Insert four 3/8" x 1.00" flanged head bolts to each socket and leave loose. Reference front drawing for direction of locking sockets.



4. Pull back on main frame towards back of truck and snug bolts. Make sure sockets are free to operate and main frame can be easily removed. Once this is done torque all bolts to 35 ft-lbs. **NOTE:** Locking sockets are in the locking position in picture. Once bolts are checked once again make sure frame can be removed and operate properly.

IMPORTANT NOTE: Apply a little grease or lubricant to the part of the pins that insert into the mounting pods to help maintain smooth operation and rotation of pins and to protect from the elements. Turn the pins occasionally to prevent them from seizing. If handles turn to hard for desired fit remove nut on bottom of handle and remove one shim from top bushing.