



Doing Our Best to Provide You the Best

HJ26331, Rev 0
08/19

5TH WHEEL DOUBLE PIVOT SADDLE ASSEMBLY

6331 Chevrolet/GMC

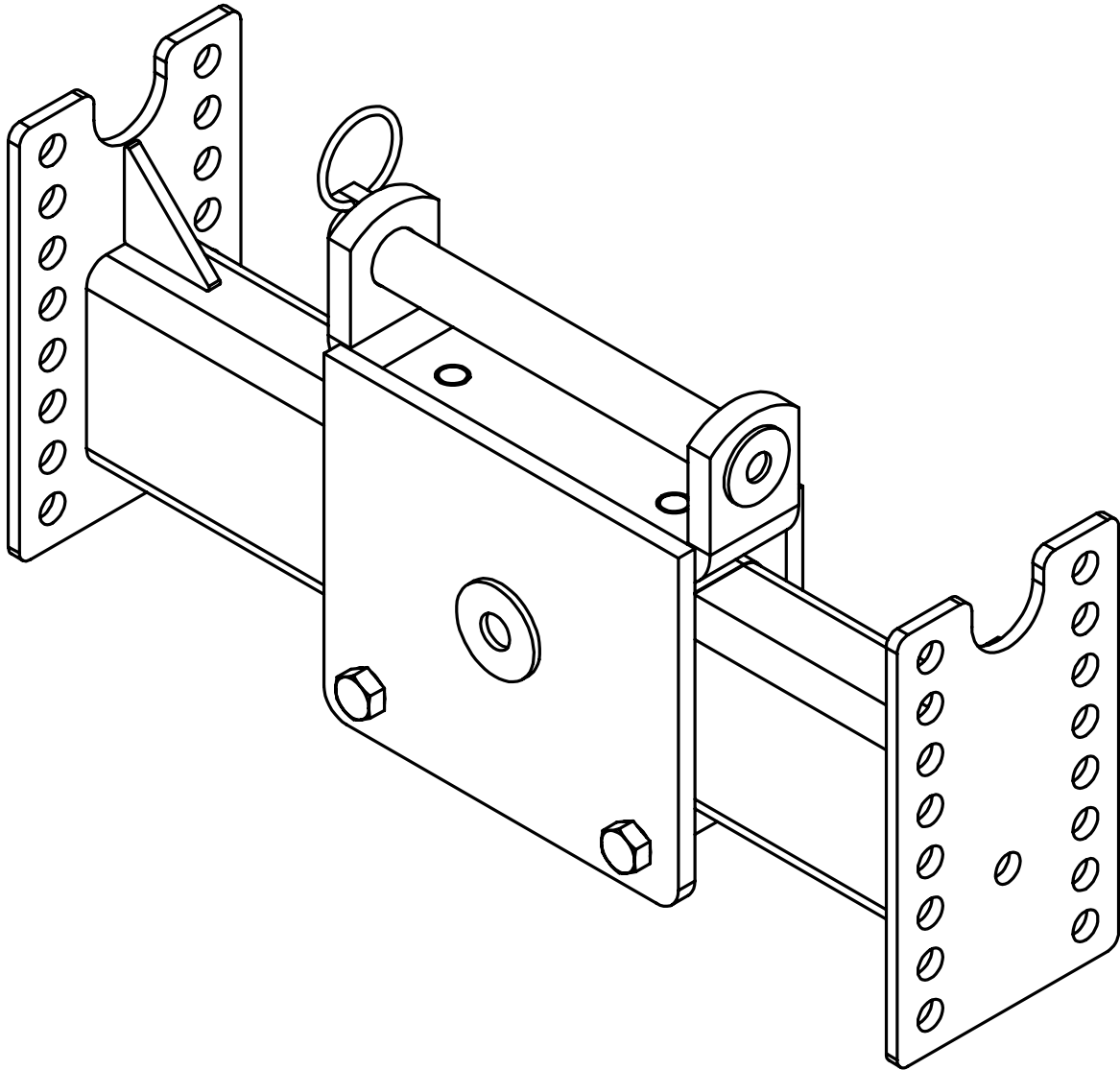

OPERATOR MANUAL

WARRANTY POLICY, OPERATOR MANUALS, PARTS MANUALS & REGISTRATION

Go online to www.demco-products.com to review Demco warranty policies, operator manuals and register your Demco product.

Torque Specifications

BOLT TORQUE DATA FOR STANDARD NUTS, BOLTS, AND CAPSCREWS.

Tighten all bolts to torques specified in chart unless otherwise noted. Check tightness of bolts periodically, using bolt chart as guide. Replace hardware with same grade bolt.

NOTE: Unless otherwise specified, high-strength Grade 5 hex bolts are used throughout assembly of equipment.

Torque figures indicated are valid for non-greased or non-oiled threads and heads unless otherwise specified. Therefore, do not grease or oil bolts or capscrews unless otherwise specified in this manual. When using locking elements, increase torque values by 5%.

* GRADE or CLASS value for bolts and capscrews are identified by their head markings.

Bolt Torque for Standard bolts *

"A"	GRADE 2		GRADE 5		GRADE 8	
	lb-ft	(N.m)	lb-ft	(N.m)	lb-ft	(N.m)
1/4"	6	(8)	9	(12)	12	(16)
5/16"	10	(13)	18	(25)	25	(35)
3/8"	20	(27)	30	(40)	45	(60)
7/16"	30	(40)	50	(70)	80	(110)
1/2"	45	(60)	75	(100)	115	(155)
9/16"	70	(95)	115	(155)	165	(220)
5/8"	95	(130)	150	(200)	225	(300)
3/4"	165	(225)	290	(390)	400	(540)
7/8"	170	(230)	420	(570)	650	(880)
1"	225	(300)	630	(850)	970	(1310)

Bolt Torque for Metric bolts *

"A"	CLASS 8.8		CLASS 9.8		CLASS 10.9	
	lb-ft	(N.m)	lb-ft	(N.m)	lb-ft	(N.m)
6	9	(13)	10	(14)	13	(17)
7	15	(21)	18	(24)	21	(29)
8	23	(31)	25	(34)	31	(42)
10	45	(61)	50	(68)	61	(83)
12	78	(106)	88	(118)	106	(144)
14	125	(169)	140	(189)	170	(230)
16	194	(263)	216	(293)	263	(357)
18	268	(363)	--	--	364	(493)
20	378	(513)	--	--	515	(689)
22	516	(699)	--	--	702	(952)
24	654	(886)	--	--	890	(1206)

6331 DOUBLE PIVOT SADDLE ASSEMBLY

The saddle bracket assembly is pre-assembled at the factory. Attach to side rails by following hitch assembly instructions that accompany the side rails and base rails. Hitch attachment instructions are included in the 5th wheel head instructions.

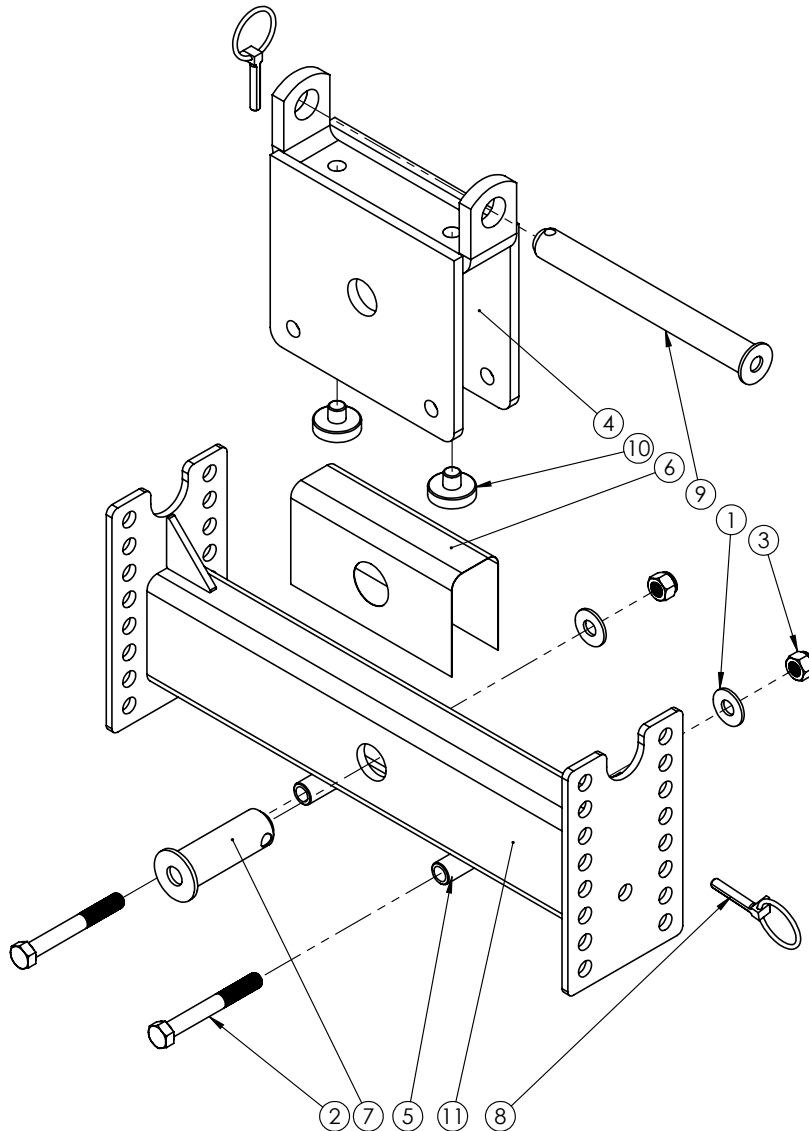

6331 Parts List

ITEM	PART #	QTY	DESCRIPTION
1	00085	2	.50 FLAT WASHER
2	01896	2	BOLT, .50 NC X 4.00 HEX HEAD GR.5
3	02178	2	NUT, .50 NC LOCK, NY. INSERT
4	14150-76	1	PIVOT SADDLE ASSEMBLY
5	14153-95	2	PIVOT SPACER BUSHING
6	14207	1	TEFLON SHIM
7	14209-95	1	PIVOT PIN ASSY.
8	14221	2	LYNCH PIN, .313
9	14222-95	1	AS PIVOT PIN 1" X 9.38
10	15769	2	URETHANE PIVOT BUMPER 3/8" THICK
11	16848-76	1	GM PIVOT SADDLE TUBE ASSY.

Please order replacement parts by **PART NO.** and **DESCRIPTION.**

DEMCO

4010 320th St., Boyden, IA. 51234

Phone: (712) 725-2311

Fax: (712) 725-2380

Toll Free: 1-800-54DEMCO (1-800-543-3626)

**Demco warranty policies, operator manuals, and product registration
can be found online:**

www.demco-products.com

