

## FRAME BRACKET 8551009

Ford F250/F350 Super Duty 6-1/2' & 8' Box

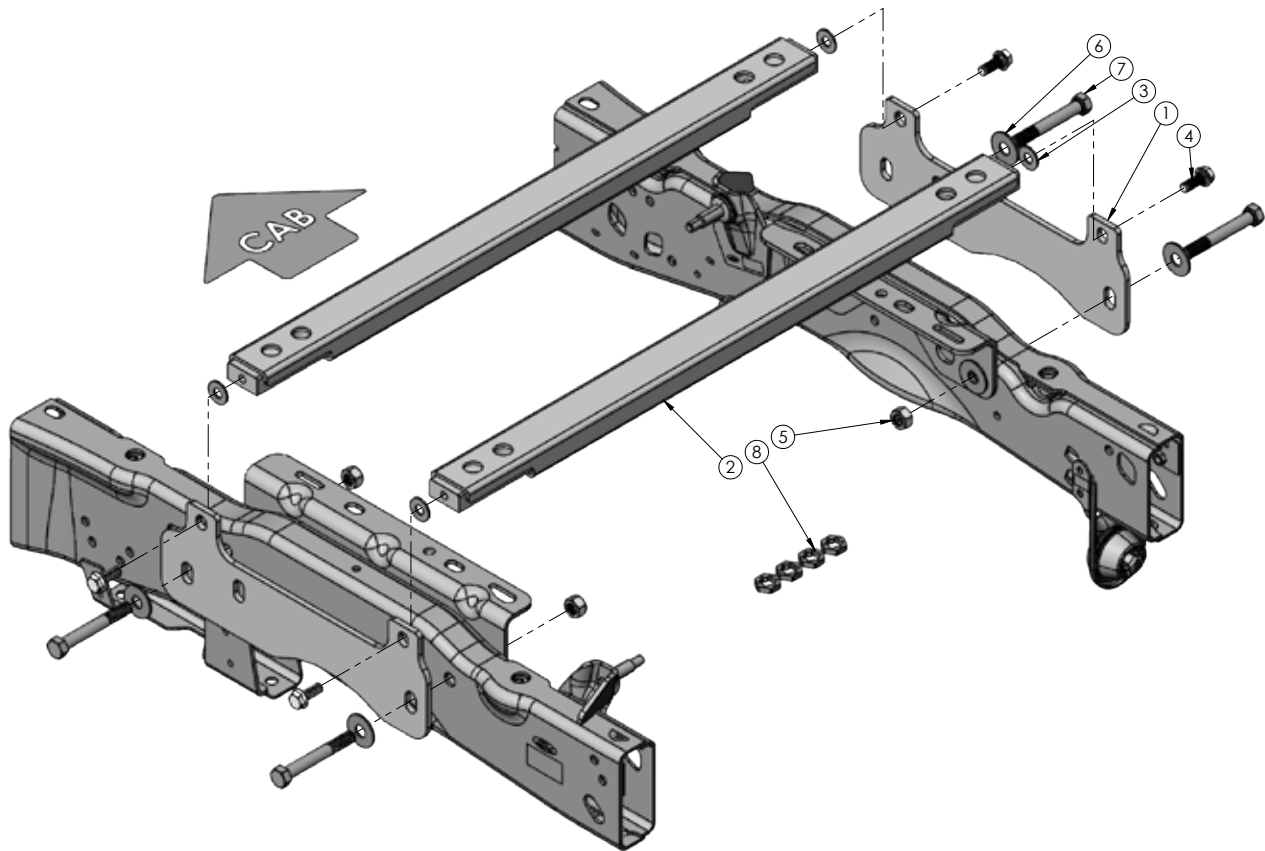

ITEM	PART #	QTY	DESCRIPTION
1	<b>15845-76</b>	2	FRAME BRACKET
2	<b>15846-76</b>	2	BASE RAIL
3	<b>00085</b>	4	FLAT WASHER .50
4	<b>14055</b>	4	BOLT, .50NC X 1.25 SERR FLG HEX HD
5	<b>02587</b>	4	NUT, .625NC NYLON LOCK
6	<b>00477</b>	8	FLAT WASHER .625
7	<b>02434</b>	4	BOLT, .625NC X 4.50 HEX HD GR.5
8	<b>15844</b>	4	BOX BOLT ADAPTOR
9	<b>14335</b>	4	CAP PLUG (not shown)
10	<b>15367</b>	4	VINYL 5" (not shown)

Please order replacement parts by **PART NO.** and **DESCRIPTION.**

# Installation

## 8551009 General Assembly & Install Instructions

### WARRANTY POLICY, OPERATOR MANUALS & REGISTRATION

Go online to [www.demco-products.com](http://www.demco-products.com) to review Demco warranty policies, operator manuals and register your Demco product.

#### BOLT TORQUE SPECIFICATIONS

STANDARD BOLTS			METRIC BOLTS		
Size	Grade	Torque	Size	Grade	Torque
5/16"	5	18 ft/lbs.	8mm	8.8	23 ft/lbs.
3/8"	5	30 ft/lbs.	10mm	8.8	45 ft/lbs.
7/16"	5	50 ft/lbs.	12mm	8.8	78 ft/lbs.
1/2"	5	75 ft/lbs.	14mm	8.8	125 ft/lbs.
5/8"	5	150 ft/lbs.	16mm	8.8	160 ft/lbs.
3/4"	5	290 ft/lbs.			

#### Hitch Assembly:

1. Place the base rails on a flat level surface. Insert and lock the side rail plates into the base rail holes as shown in the supplied hitch instructions.
2. Loosely bolt the saddle bracket and the two cross brackets to the side rails using the fasteners provided with the hitch.
3. Tighten all bolts according to the bolt torque specification chart.
4. Unlock and remove the hitch assembly from the base rails and put to the side for later.

#### Truck Bed Drilling Instructions:

1. Use the measurements shown on the drill hole measurement chart to mark out the four holes that will be drilled through the truck bed.
2. Start out by measuring the distance stated for the particular **BOX LENGTH** of truck you are doing the installation on (refer to page 3) from the end of the bottom of the truck bed (tailgate end) to a point on the left side of center of the bed and mark it. Do the same on the right side of center of the bed and mark it. Draw a line across the bed using these two marks as a reference.
3. Measure out and find the center of the truck bed and draw a line from the front to the rear of the bed.
4. Measure out 14 13/16" to either side of the middle center line slightly ahead of the fender well and slightly behind the fender well.
5. Draw a line between these two points. Do the same on the other side.
6. Measure out (towards the cab) 13 1/2" from the points where the line that goes across the bed intersects with the two lines that are 14 13/16" off the center running the length of the bed. Mark these two points.
7. There should now be four spots marked out for drilling. Double check that the rear to hole marks are exactly the distance stated for the box length of truck you are doing the installation on (refer to box length on chart) from end of the bed and that the front holes marks are exactly 13 1/2" forward of those marks.
8. Check the hole marks from side to side and make sure they are exactly 29 5/8" apart from each other.
9. Finally, check for square by measuring diagonally from opposite corners **Drawing #1**. The measurement should be the same both ways. It should measure 32 9/16".
10. After all the hole marks have been double checked for proper placement, use a center punch and hammer to mark out the spots for drilling.
11. Drill the holes using a 2" hole saw. Deburr the holes using a small file and apply some touch up paint to match color (not supplied).

Drawing #1

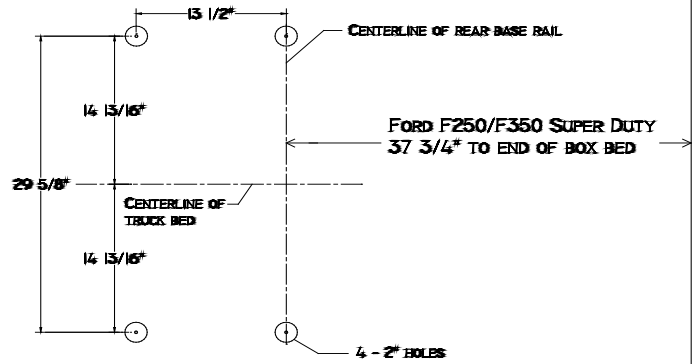

Drawing #2

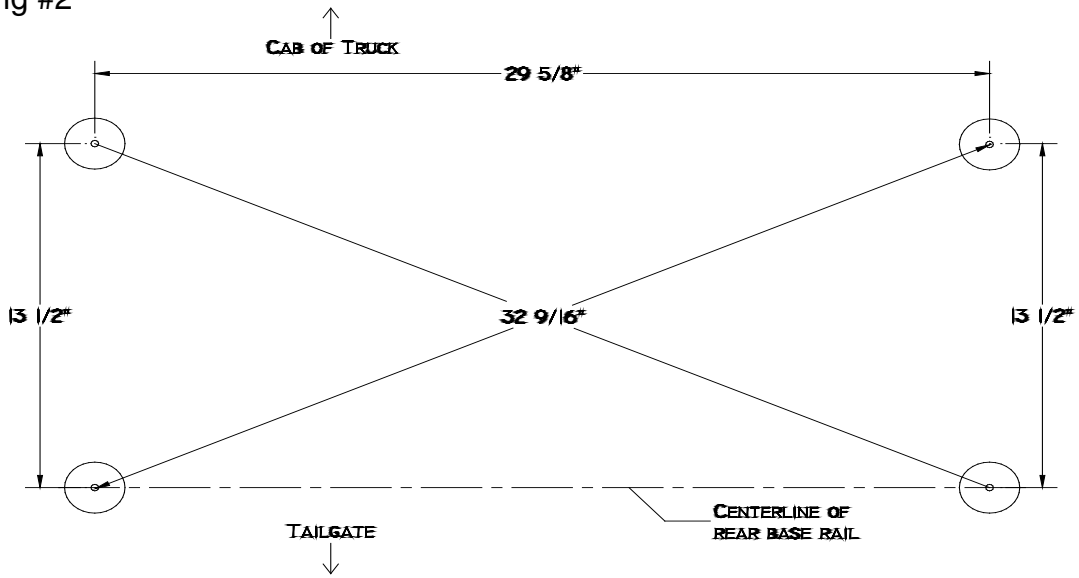

# Installation

---

## Truck Bed Drilling Instructions with Template

1. Place the template in the box and center the template between the wheel wells.
2. **IF NEEDED, TAPE THE TEMPLATE DOWN.**
3. Measure from the back of the box to the template on the passengers side and drivers side to insure that the template is square. See **DRAWING #1** and table for measurements.
4. Locate which holes you will be drilling, by the ones marked with a red arrow.
5. Take a 3/8" locating punch and mark the holes to be drilled.
6. **BEFORE YOU DRILL, MAKE SURE THAT THE TEMPLATE DID NOT MOVE, AND THAT THERE ARE NO OBSTRUCTIONS IN THE WAY.**
7. Remove the template and drill the four marked holes with a 2" hole saw.
8. Deburr each hole.
9. Touch up the bare metal with some paint that matches the box of the truck.

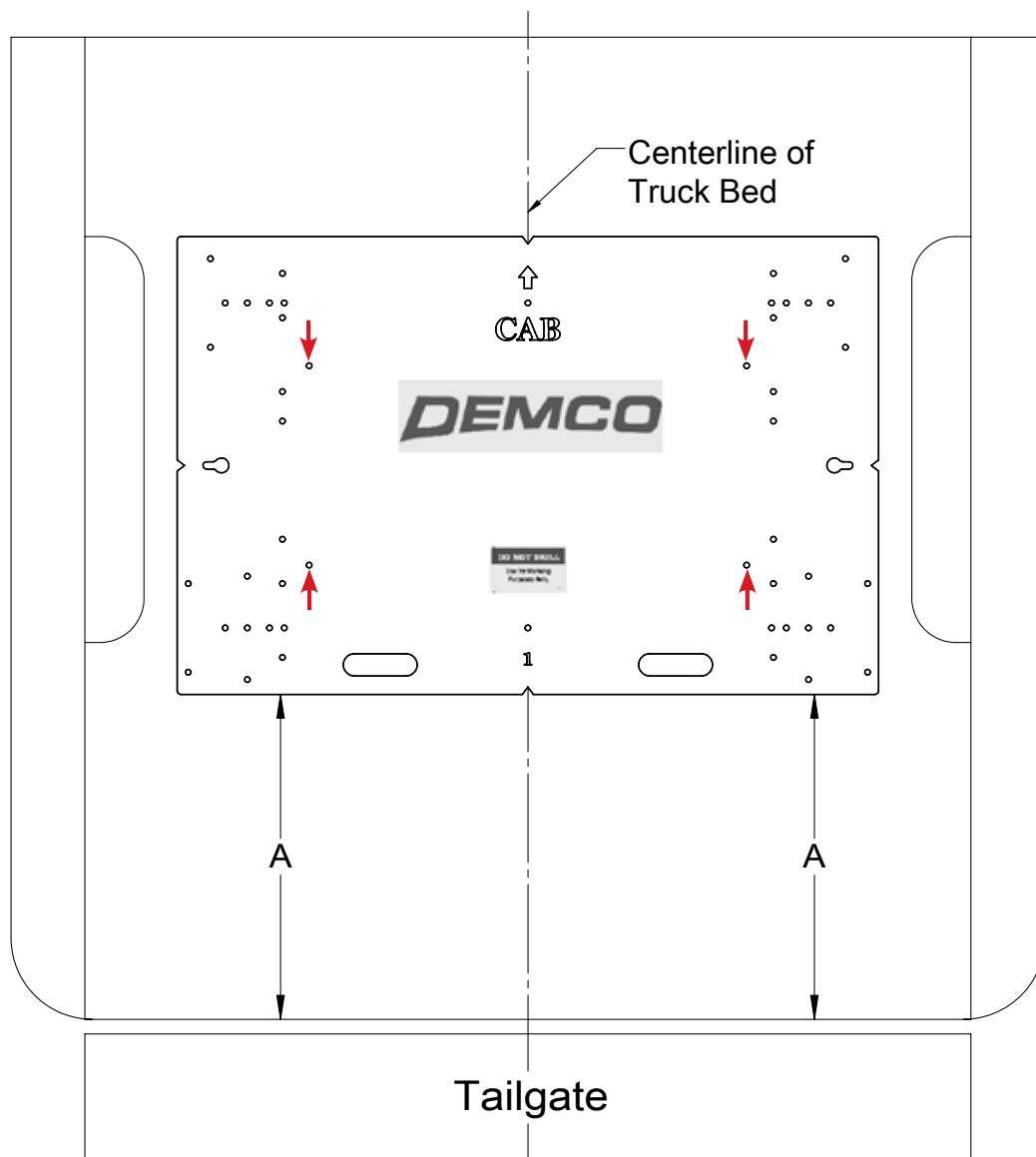

**Drawing #1**

BOX LENGTH	DIMENSIONS	MEASUREMENT
5-1/2'	A	*N/A
6-1/2'	A	*29"
8'	A	*29"
*ALL MEASUREMENTS ARE FROM THE BACK OF THE BOX		

# Installation

## Base Rail Installation

1. With the four 2" holes drilled in the truck bed, remove 4 box bolts from passenger side of truck bed. Loosen drivers side box bolts about a 1/4" up. Use Torx Plus 24 EP socket or included box bolt adaptor. **NOTE:** If inside of box has spray in bed liner (factory or after market), liner material must be removed from bolt head before using socket or box bolt adaptor. If using the box bolt adaptor, use 1-1/8" socket over top adaptor. Using a 1/2" drive air gun works best.
2. The top of each base rail will need to be covered with included vinyl. Cut vinyl to the length of base rail tubing, then cut vinyl length ways. Your piece of vinyl should measure about 2-1/2" x 36-1/2". This vinyl will be against the bottom of the box if installed correctly on the base rail.
3. Carefully raise truck bed approximately 2" off of frame on passenger side. One at a time, slide rail from passenger side to drivers side. See picture for approximate location. This is only temporary, side frame brackets and hitch assembly will locate rails to proper location. Lower box down but don't put box bolts in yet. **NOTE:** When lowering box, make sure plastic alignment pin enters its alignment hole located on front passenger side frame mount by front box bolt.

Drivers side shown



4. With base rails in position below the bed, reinstall and lock the hitch assembly through 2" drilled holes and into the base rails from the top side of the box.
5. Measure and center the entire hitch assembly side to side and front to back so that it is as close to center of the holes in the bed.
6. Attach the drivers and passenger frame brackets against frame using existing holes in frame. Use 5/8" x 4-1/2" bolts, 5/8" flatwashers (1 washer per side of the frame) and 5/8" nylon lock nut. Do not tighten.
7. Raise frame bracket up so it can be bolted to rails with 1/2" x 1-1/4" serrated flange head bolt. Before installing bolt, put 1/2" flatwasher behind frame bracket and against steel block in rail. Install bolt but do not tighten. Do this on each rail block.
8. Reinstall and tighten all eight box bolts.
9. Tighten all frame bracket bolts.
10. Unlock and lift the hitch assembly out of the box to make sure it can be removed and inserted with relative ease. If there was any shifting during installation that caused any binding, simply loosen the four bolts that attach the base rail to the frame brackets and re-align the base rail and re-tighten.
11. Ensure the side rail locking pins are turned and secured in the locked position with the safety pins. Install the hitch head to the saddle bracket.



# **DEMCO**

4010 320th St., Boyden, IA. 51234

Phone: (712) 725-2311

Fax: (712) 725-2380

Toll Free: 1-800-54DEMCO (1-800-543-3626)

**Demco warranty policies, operator manuals, and product registration  
can be found online:**

**[www.demco-products.com](http://www.demco-products.com)**

