

FRAME BRACKET 8552006

Ford

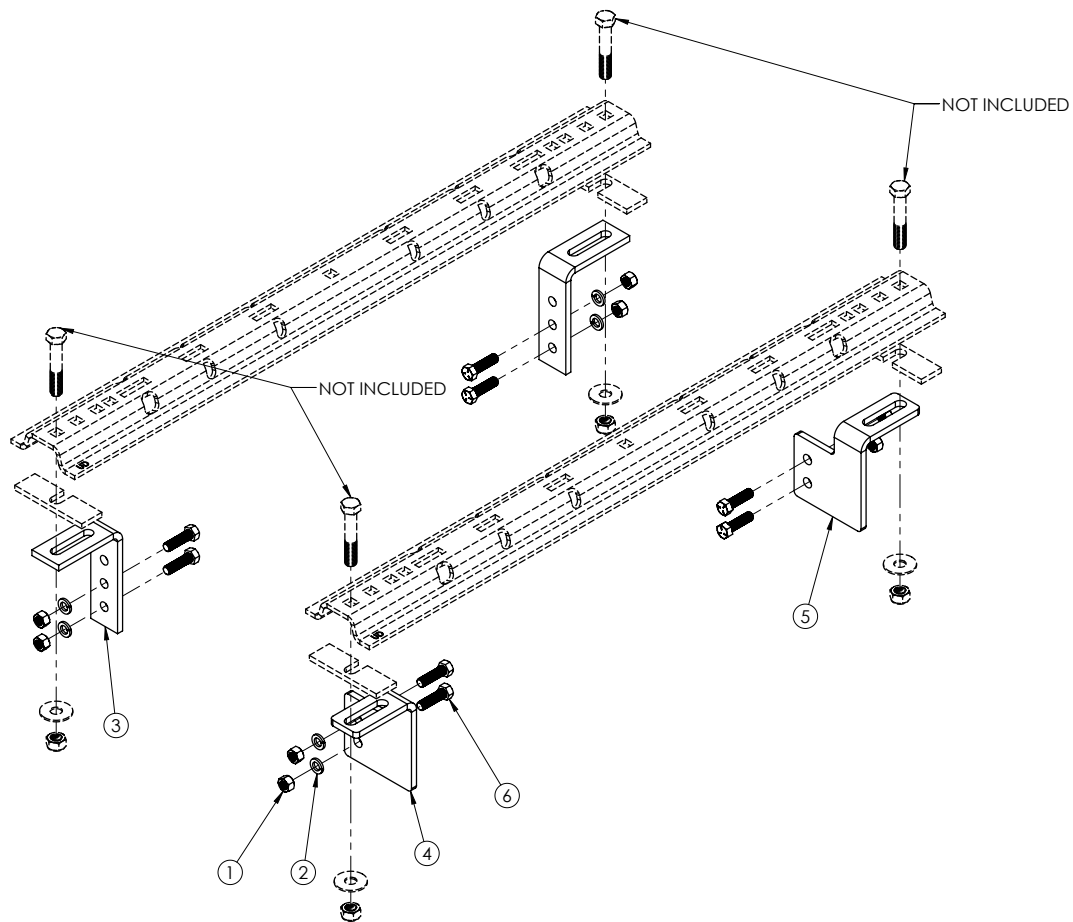

ITEM	PART #	QTY	DESCRIPTION
1	00083	8	NUT, .50NC HEX
2	00084	8	WASHER, .50 LOCK
3	14189-76	2	FRAME BRACKET
4	14197-76	1	411 ER FRAME BRACKET DRIVER SIDE
5	14198-76	1	411 EL FRAME BRACKET PASSENGER SIDE
6	14266	8	BOLT, .50NC X 1-3/4" HEX KNURL GR.5
7	14238	1	FISH WIRE .50 (NOT SHOWN)

Please order replacement parts by **PART NO.** and **DESCRIPTION.**

Installation

8552006 General Assembly & Installation Instructions

WARRANTY POLICY, OPERATOR MANUALS & REGISTRATION

Go online to www.demco-products.com to review Demco warranty policies, operator manuals and register your Demco product.

BOLT TORQUE SPECIFICATIONS

STANDARD BOLTS			METRIC BOLTS		
Size	Grade	Torque	Size	Grade	Torque
5/16"	5	18 ft/lbs.	8mm	8.8	23 ft/lbs.
3/8"	5	30 ft/lbs.	10mm	8.8	45 ft/lbs.
7/16"	5	50 ft/lbs.	12mm	8.8	78 ft/lbs.
1/2"	5	75 ft/lbs.	14mm	8.8	125 ft/lbs.
5/8"	5	150 ft/lbs.	16mm	8.8	160 ft/lbs.
3/4"	5	290 ft/lbs.			

CAUTION: Do not install base rails over plastic bed liners. Plastic bed liners must be cut out of the way. Rails may be installed on spray in liners.

NOTE: All metal surfaces that come in contact with the aluminum body need to have vinyl placed in between to prevent corrosion.

NOTE: Consult spray liner installer for recommended curing time.

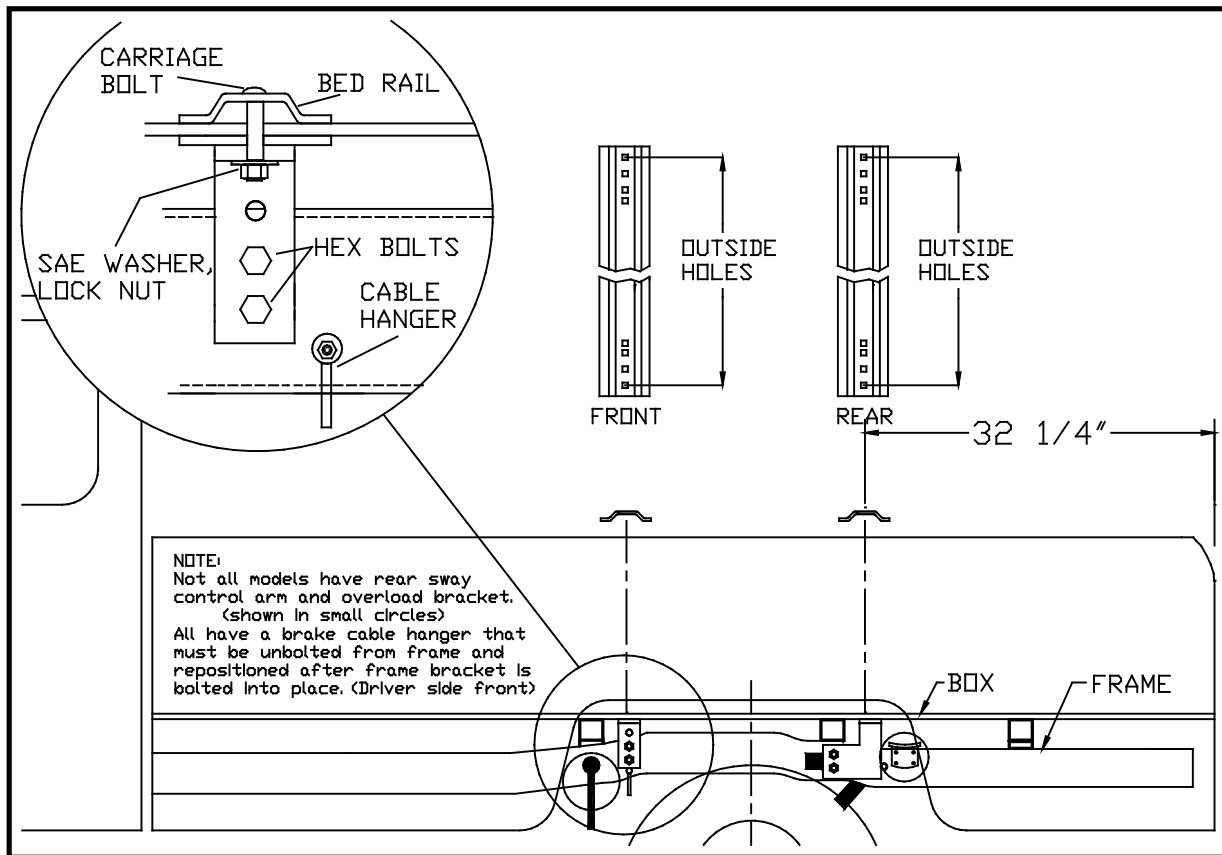

INSTALLATION

1.
 - a. Completely assemble hitch. See GENERAL INSTRUCTIONS and SAFETY supplied.
 - b. Set hitch into back of truck, center it side to side.
 - c. Measure 32 1/4" from back edge of truck box to square hole centers in rear bed rail.
 2. Check underneath box at bolt hole locations for any obstruction (gas line, wiring, etc.).
 3.
 - a. Drill two 5/8" holes thru FRONT BED RAIL, OUTSIDE POSITION, as shown.
 - b. Insert two 5/8" x 3 1/2" bolts.
 - c. Drill two 5/8" holes in REAR BED RAIL, OUTSIDE POSITION. Insert two 5/8" x 3 1/2" bolts.
 4.
 - a. Under box, loosely install the 411 frame brackets and rear frame brackets (passenger and driver), washers, 5/8" flat washers and lock nuts in place onto the bolts (4 places).
 - b. Press each bracket tight against frame member; tighten nuts snug against box.
 5.
 - a. Pilot drill* and drill 1/2" hole into truck frame, at two places thru holes each frame bracket -- BE CAREFUL OF ELECTRIC OR FLUID LINES behind frame members.
 - b. Brackets will be bolted onto frame by drilling frame with 17/32 drill bit and fishing knurl bolt through frame with fish wire and attach with hex nut and lock washer on outside of bracket.
 - c. **TIGHTEN ALL BOLTS ACCORDING TO BOLT TORQUE SPECIFICATIONS.**
- * To pilot drill: Use 1/2" drill bit or transfer punch to mark center. Drill thru with 1/4" drill.

Truck Bed Drilling Instructions with Template

1. Place the template in the box and center the template between the wheel wells.
2. **IF NEEDED, TAPE THE TEMPLATE DOWN.**
3. Measure from the back of the box to the template on the passenger side and driver side to insure that the template is square. See **DRAWING #1** and table for measurements.
4. Locate which holes you will be drilling, by the ones marked with a red arrow.
5. Take a 3/8" locating punch and mark the holes to be drilled.
6. **BEFORE YOU DRILL, MAKE SURE THAT THE TEMPLATE DID NOT MOVE, AND THAT THERE ARE NO OBSTRUCTIONS IN THE WAY.**
7. Remove the template and drill the four marked holes with a 5/8" drill bit.
NOTE: A pilot hole may need to be drilled.
8. Deburr each hole.
9. Touch up the bare metal with some paint that matches the box of the truck.

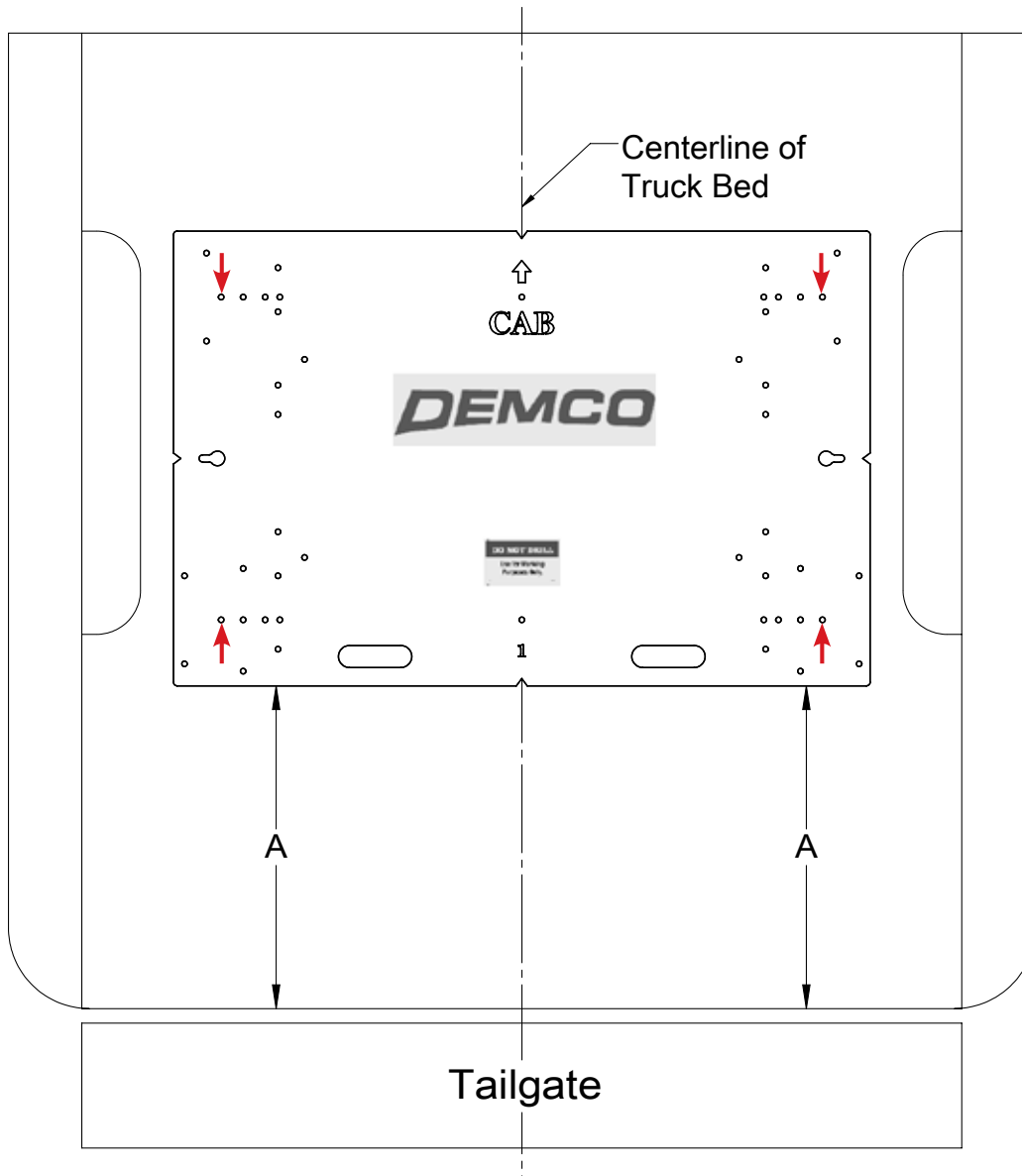

Drawing #1

BOX LENGTH	DIMENSIONS	MEASUREMENT
FORD F250 & F350 "SUPER DUTY"		
6-1/2'	A	*27-3/4"
8'	A	*27-3/4"
*ALL MEASUREMENTS ARE FROM THE BACK OF THE BOX		

DEMCO

4010 320th St., Boyden, IA. 51234

Phone: (712) 725-2311

Fax: (712) 725-2380

Toll Free: 1-800-54DEMCO (1-800-543-3626)

**Demco warranty policies, operator manuals, and product registration
can be found online:**

www.demco-products.com

