

FRAME BRACKET 8552031

Ford F250/F350 Super Duty 6-1/2' & 8' Box & Ford F450 Super Duty 8' Box

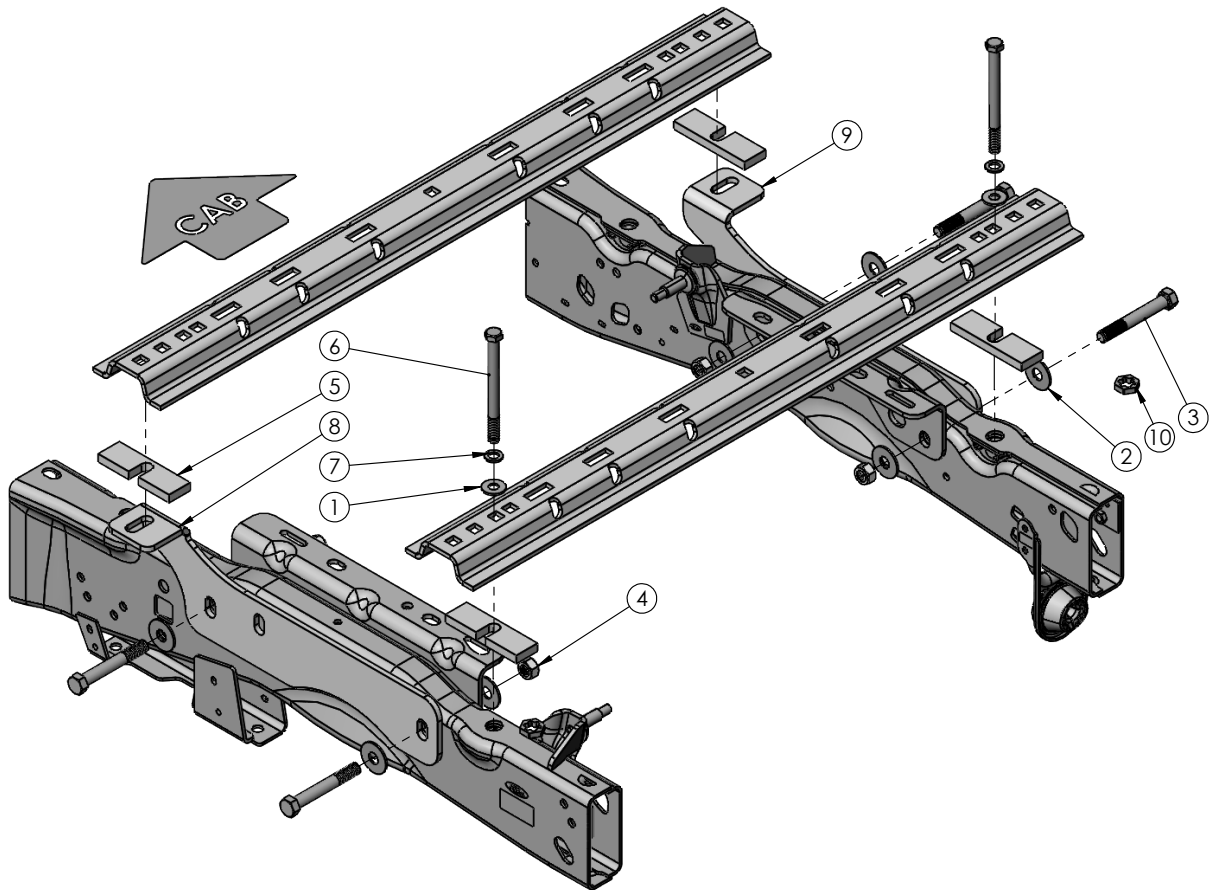

ITEM	PART #	QTY	DESCRIPTION
1	00085	2	WASHER, FLAT .50
2	00477	8	WASHER, FLAT .625
3	02434	4	BOLT, .625NC X 4.50 HEX GR.5
4	02587	4	NUT, .625NC NYLON LOCK
5	15839-95	4	UL BASE SHIM
6	15840	2	BOLT, 14MM X 2MM X 160MM GR.8.8 HEX
7	15841	2	WASHER, SPRING LOCK 14MM
8	15842-76	1	DRIVER BRACKET FRAME MOUNT
9	15843-76	1	PASSENGER FRAME BRACKET
10	15844	2	BOX BOLT ADAPTOR
11	15367	10'	VINYL 5" (not shown)

Please order replacement parts by PART NO. and DESCRIPTION.

Installation

8553031 General Assembly & Installation Instructions

WARRANTY POLICY, OPERATOR MANUALS & REGISTRATION

Go online to www.demco-products.com to review Demco warranty policies, operator manuals and register your Demco product.

BOLT TORQUE SPECIFICATIONS

STANDARD BOLTS			METRIC BOLTS		
Size	Grade	Torque	Size	Grade	Torque
5/16"	5	18 ft/lbs.	8mm	8.8	23 ft/lbs.
3/8"	5	30 ft/lbs.	10mm	8.8	45 ft/lbs.
7/16"	5	50 ft/lbs.	12mm	8.8	78 ft/lbs.
1/2"	5	75 ft/lbs.	14mm	8.8	125 ft/lbs.
5/8"	5	150 ft/lbs.	16mm	8.8	160 ft/lbs.
3/4"	5	290 ft/lbs.			

CAUTION: Do not install base rails over plastic bed liners. Plastic bed liners must be cut out of the way. Rails may be installed on spray in liners.

NOTE: All metal surfaces that come in contact with the aluminum body need to have vinyl placed in between to prevent corrosion.

NOTE: Consult spray liner installer for recommended curing time.

1. Fully assemble the 5th wheel hitch on a flat, level surface and set aside for later. **NOTE:** Assembly instructions come with hitch components.
2. Remove rear inner wheel well inserts if equipped.
3. Inside of the box, remove 2 box bolts, second row from the back of the box (34 1/2" from back of box to center of bolt) see below picture. Use Torx Plus #24 EP or supplied box bolt adapter. **NOTE:** If inside of box has spray in bed liner (factory or after market), liner material must be removed from bolt head before using socket or box bolt adapter. Use 1-1/8" socket to remove bolts. Bolts will not be reused. **NOTE:** Using 1/2" drive air gun works best.

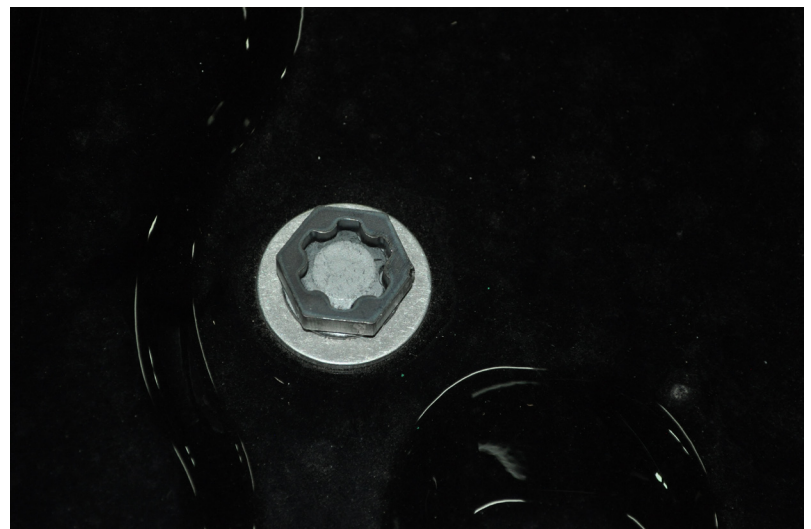
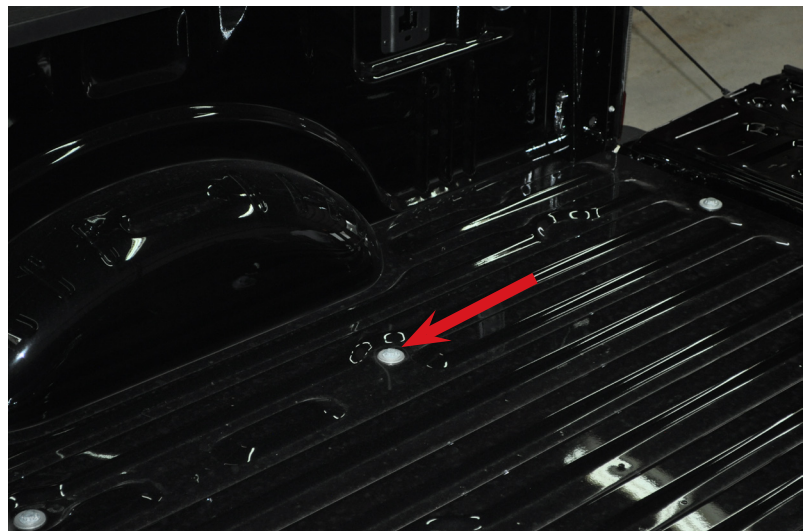

4. Apply vinyl to each leg of the rail and box spacer and place them in the box over the factory holes in the box. Using 14mm x 160mm bolts, 14mm lockwashers and 1/2" flatwashers placed in the third from the outside mounting hole in the rail on each side. Make sure the rail is parallel to the back of the pickup box and tighten according to the chart specifications on the front page. See picture below. **NOTE:** foam applied in picture to show where vinyl is to be applied.

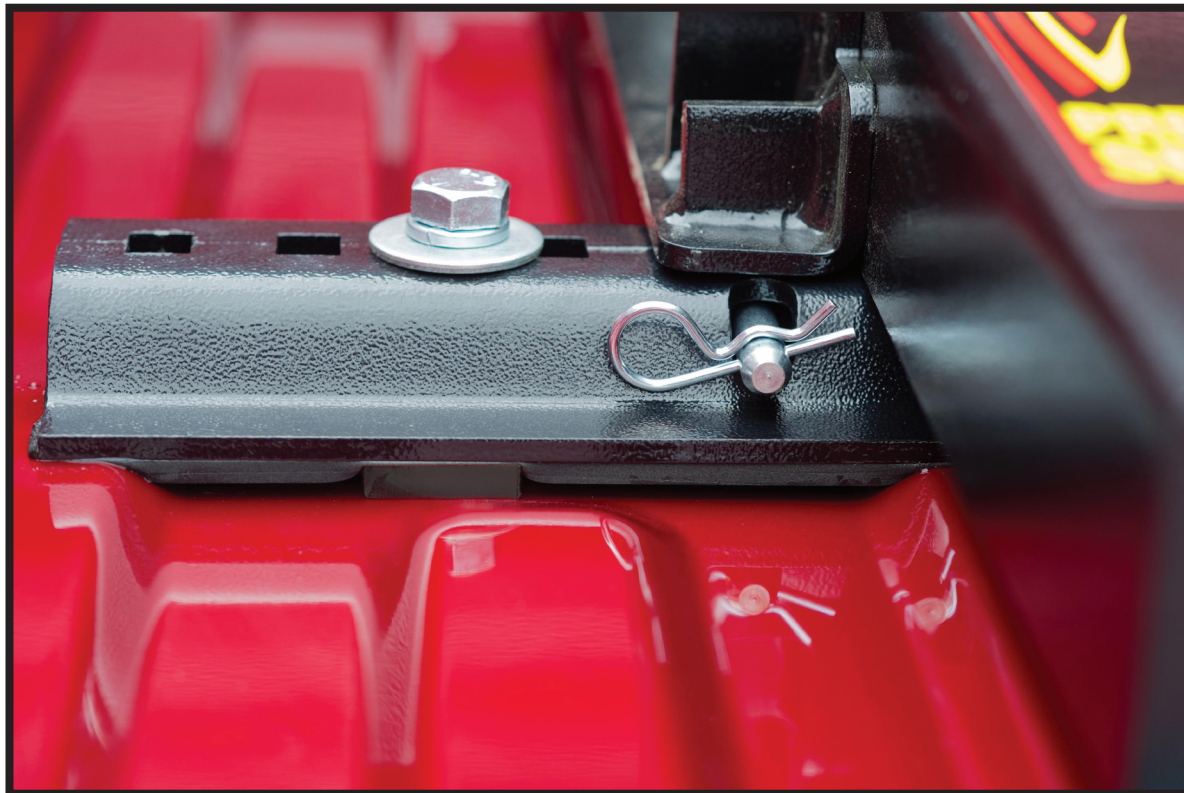

5. Apply vinyl to the front rail and box spacers. Place front rail into the box and place the hitch in the rails.
6. Make sure the front and rear rails are parallel to each other. Drill a 5/8" hole on each side using the first outside mounting hole (look below the box before drilling to make sure nothing is in the way of the drill bit). Remove the front rail and hitch. Using some paint, touch up the drilled hole to prevent corrosion. Reinstall front rail and hitch. Make sure the rail is once again parallel to the rear rail.
7. Attach drivers and passenger frame brackets against frame using existing holes in frame. Use 5/8" x 4-1/2" bolts and 5/8" flatwashers, 1 washer per side of the frame and 5/8" nylon locknut. Push bracket up so mounting tab is tight with the bottom of the box and tighten bolts.
8. Using the supplied bolts from the 6071 rail kit, install the bolts and tighten to the chart on front page. **NOTE:** Included in this kit are 1/2" thick UL base shims. Use these and not shims from 6071 kit because truck box floor has deeper corrugation.
9. Reinstall the rear wheel well inserts if equipped.

Installation

Truck Bed Drilling Instructions with Template

1. Place the template in the box and center the template between the wheel wells.
2. **IF NEEDED, TAPE THE TEMPLATE DOWN.**
3. Measure from the back of the box to the template on the passengers side and drivers side to insure that the template is square. See drawing #1 and table for measurements.
4. Locate which holes you will be drilling, by the ones marked with a red arrow.
5. Take a 3/8" locating punch and mark the holes to be drilled.
6. **BEFORE YOU DRILL, MAKE SURE THAT THE TEMPLATE DID NOT MOVE, AND THAT THERE ARE NO OBSTRUCTIONS IN THE WAY.**
7. Remove the template and drill the four marked holes with a 5/8" drill bit.
NOTE: A pilot hole may need to be drilled.
8. Deburr each hole.
9. Touch up the bare metal with some paint that matches the box of the truck.

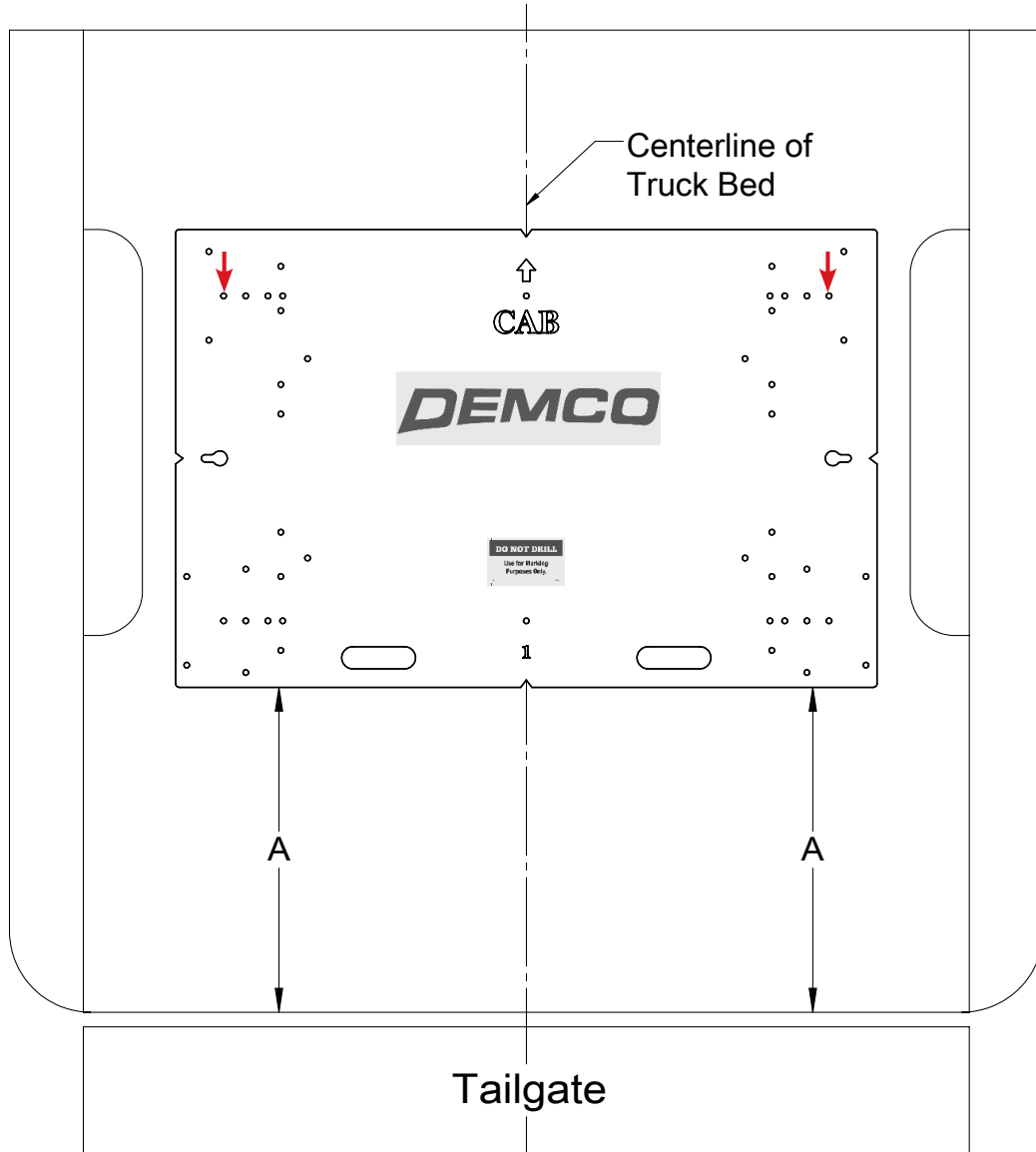

Drawing #1

BOX LENGTH	DIMENSIONS	MEASUREMENT
5-1/2'	A	*N/A
6-1/2'	A	*30"
8'	A	*30"
*ALL MEASUREMENTS ARE FROM THE BACK OF THE BOX		

DEMCO

4010 320th St., Boyden, IA. 51234

Phone: (712) 725-2311

Fax: (712) 725-2380

Toll Free: 1-800-54DEMCO (1-800-543-3626)

**Demco warranty policies, operator manuals, and product registration
can be found online:**

www.demco-products.com

