

FRAME BRACKET

Ford F250, F350 & F450

6 1/2' & 8' Box

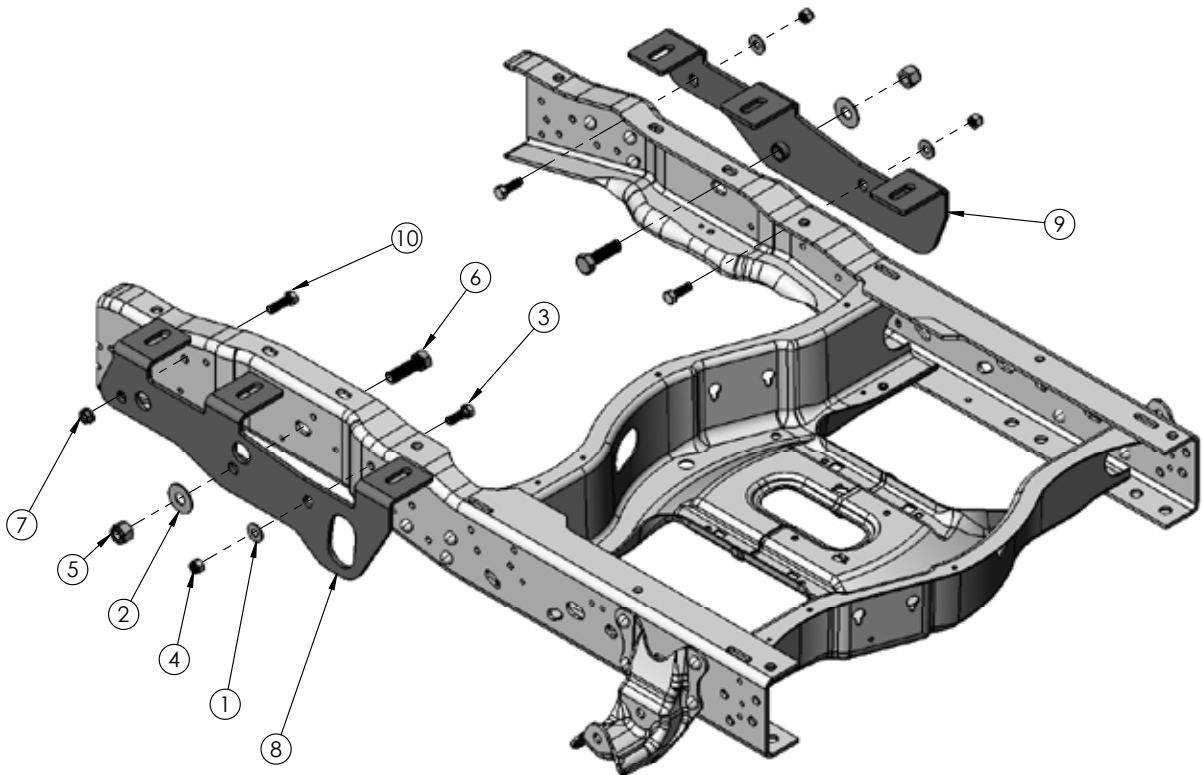

8553000 PARTS LIST

ITEM	PART #	DESCRIPTION	QTY.
1.	00085	1/2" Flat Washer	3
2.	00492	3/4" Flat Washer	2
3.	01254	1/2" NC x 1-1/2" Hex Bolt Gr.5	3
4.	02178	1/2" NC Nylon Lock Nut	3
5.	02961	3/4" NC Nylon Lock Nut	2
6.	05047	3/4" NC x 2-1/2" Hex Bolt Gr.5	2
7.	10379	1/2" NC Serrated Flange Nut	1
8.	14202-76	Frame Bracket Driver Side	1
9.	14203-76	Frame Bracket Passenger Side	1
10.	14266	1/2" NC x 1-3/4" Hex Bolt (Knurled Neck)	1
11.	14238	1/2" Fish Wire (not shown)	1

Please order replacement parts by PART NO. and DESCRIPTION.

WARRANTY POLICY, OPERATOR MANUALS & REGISTRATION

Go online to www.demco-products.com to review Demco warranty policies, operator manuals and register your Demco product.

BOLT TORQUE SPECIFICATIONS

STANDARD BOLTS			METRIC BOLTS		
Size	Grade	Torque	Size	Grade	Torque
5/16"	5	18 ft/lbs.	8mm	8.8	23 ft/lbs.
3/8"	5	30 ft/lbs.	10mm	8.8	45 ft/lbs.
7/16"	5	50 ft/lbs.	12mm	8.8	78 ft/lbs.
1/2"	5	75 ft/lbs.	14mm	8.8	125 ft/lbs.
5/8"	5	150 ft/lbs.	16mm	8.8	160 ft/lbs.
3/4"	5	290 ft/lbs.			

ILLUSTRATION 1

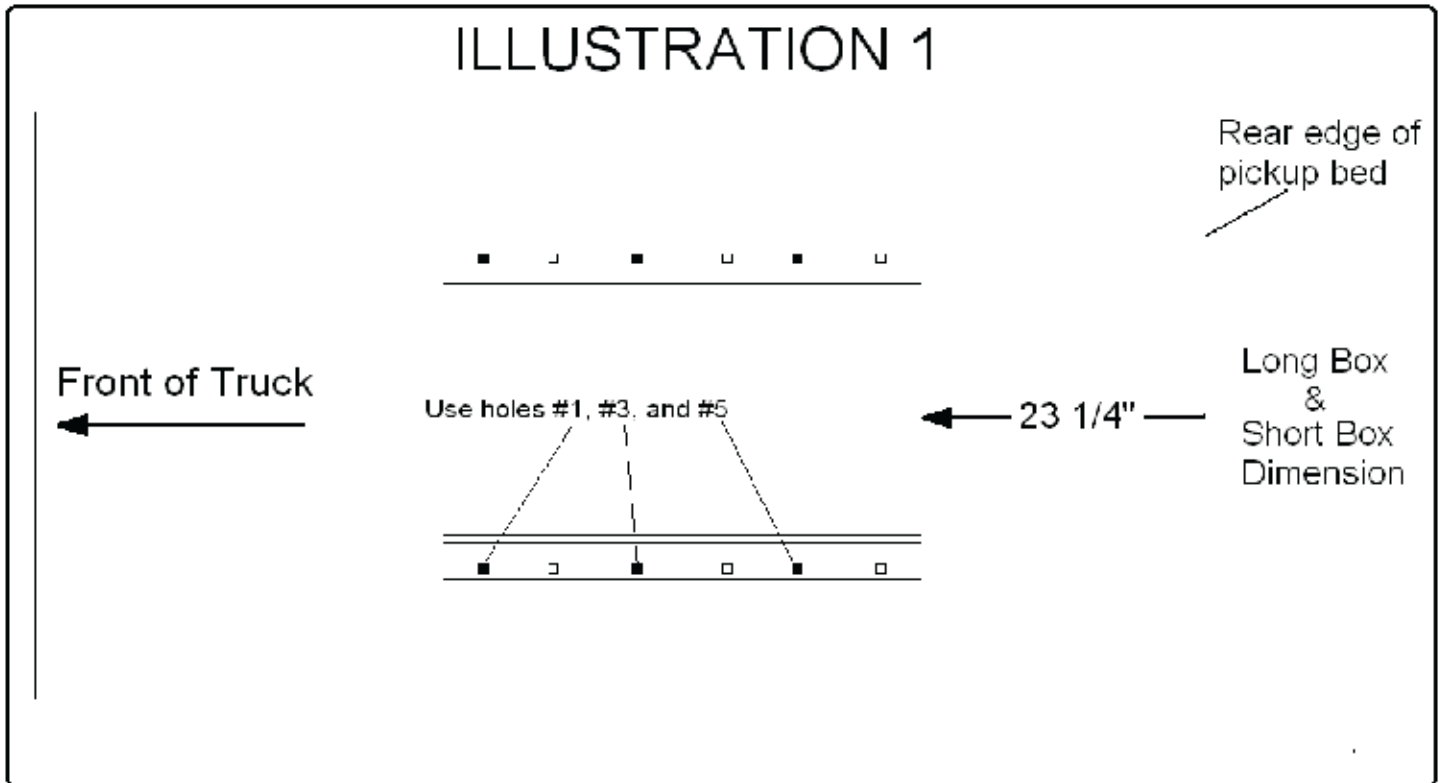

CAUTION: Do not install base rails over plastic bed liners. Plastic bed liners must be cut out of the way. Rails may be installed on spray in liners.

NOTE: Consult spray liner installer for recommended curing time.

1. Fully assemble the 5th wheel hitch on a flat, level surface and pin into the base rails (assembly instructions come with hitch components). Place assembled hitch in truck bed between the wheel wells, center it side to side and measure 23 1/4" from back edge of truck box to back edge of bed rail.
2. First check for obstruction under box, then drill two 17/32" holes thru hole #1 in each bed rail. Insert two 1/2" x 3" (04073) long hex bolts and 1/2" (07490) flat washers.
3. Lift up spring loaded locking pins and slide hitch back to rear most set of holes and lock into place. This will help to align base rails so they remain square for best operation. Drill thru hole #5 of each bed rail and insert two 1/2" x 3" (04073) long hex bolts and 1/2" (07490) flat washers, then do the same for hole #3 of each bed rail.
4. Position the left (14166-76) and right (14167-76) frame brackets up against the outer surface of the truck frame with the mounting tabs positioned over the frame and under the bed in line with the previously drilled holes in the bed where the 1/2" x 3" (04073) bolts are coming down through the bed.

5. Make sure the frame brackets are tight against the flat side of the truck frame and underneath the surface of the truck bed with bolts extending down through slotted holes in frame bracket tabs. Loosely fasten bolts with 3/16" spacer plates (14283-95) and 1/2" hex nylon lock nut (02178).
6. Each of the frame brackets must be attached to the side frame of the truck with 1/2" x 1 1/2" hex bolts (02154) and 1/2" x 1 3/4" knurl bolt (14266) (driver side front only) at the forward and rear holes and 3/4" x 2 1/2" bolt in the middle hole. See Illustration 3.

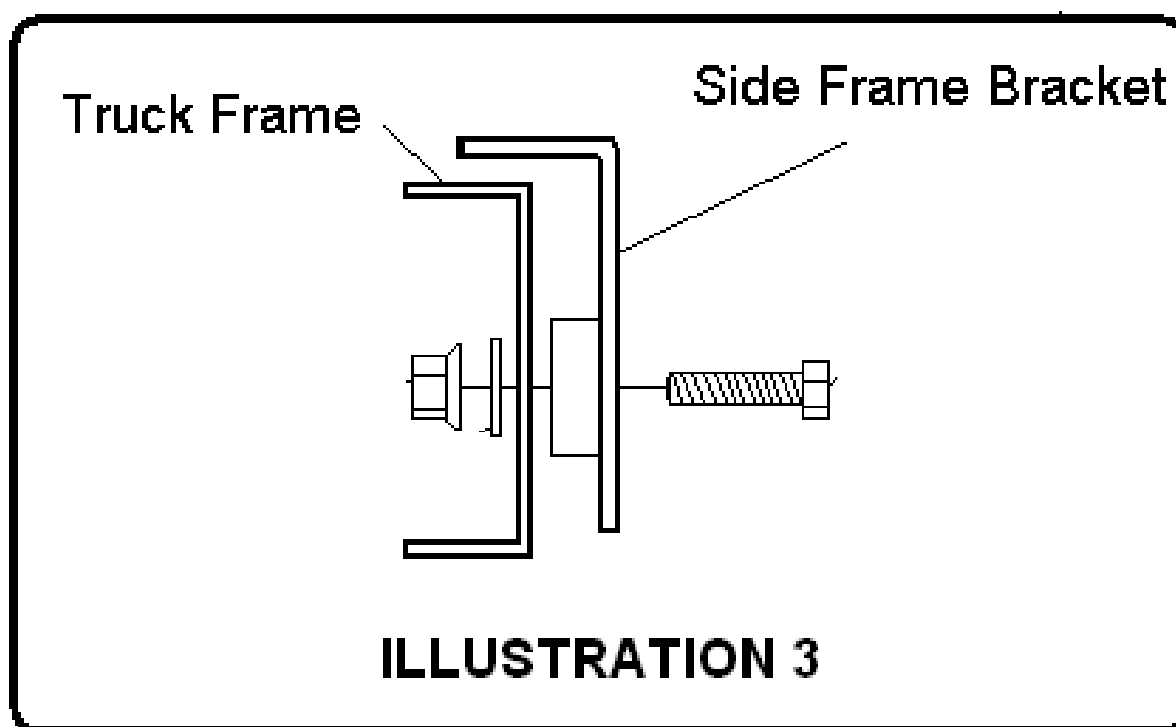

7. Tighten all bolts according to **BOLT TORQUE SPECIFICATIONS** chart. Failure to tighten bolts according to chart may result in fastener loss or failure.

DEMCO

4010 320th St., Boyden, IA. 51234

Phone: (712) 725-2311

Fax: (712) 725-2380

Toll Free: 1-800-54DEMCO (1-800-543-3626)

**Demco warranty policies, operator manuals, and product registration
can be found online:**

www.demco-products.com

