



Ford F150  
5 1/2', 6 1/2' & 8' Box

1/16  
HJ33002, Rev 3



**BOLT TORQUE SPECIFICATIONS**

**STANDARD BOLTS:**

Size	Grade	Torque	Size	Grade	Torque
5/16"	5	20 ft/lbs.	9/16"	5	123 ft/lbs.
3/8"	5	35 ft/lbs.	5/8"	5	170 ft/lbs.
7/16"	5	56 ft/lbs.	3/4"	5	305 ft/lbs.
1/2"	5	85 ft/lbs.	7/8"	5	445 ft/lbs.
			1"	5	670 ft/lbs.

# FRAME BRACKET

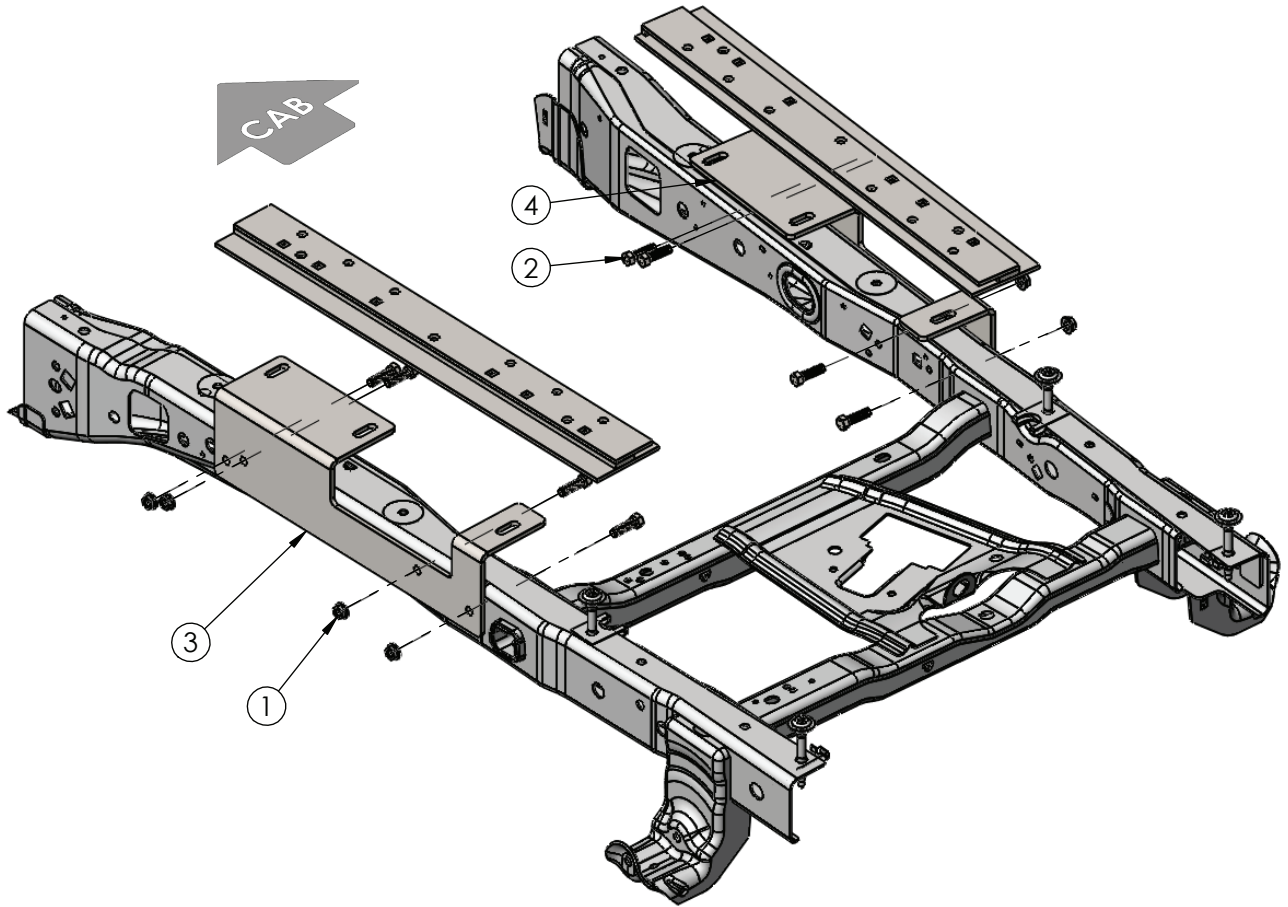

**8553002 PARTS LIST**

ITEM	PART #	DESCRIPTION	QTY.
1.	10379	1/2" Serrated Flange Nut	8
2.	14266	1/2" NC x 1 3/4" Hex Bolt Gr.5 Serrated Neck	8
3.	14370-76	Frame Bracket Driver Side	1
4.	14371-76	Frame Bracket Passenger Side	1
5.	14238	1/2" Fish Wire (not shown)	1

Please order replacement parts by **PART NO.** and **DESCRIPTION.**

ASSEMBLY  
OPERATION  
REPLACEMENT PARTS

**READ** complete manual CAREFULLY  
BEFORE attempting operation.

Doing Our Best to Provide You the Best

## WARRANTY POLICY, OPERATOR MANUALS & REGISTRATION

Go online to [www.demco-products.com](http://www.demco-products.com) to review Demco warranty policies, operator manuals and register your Demco product.

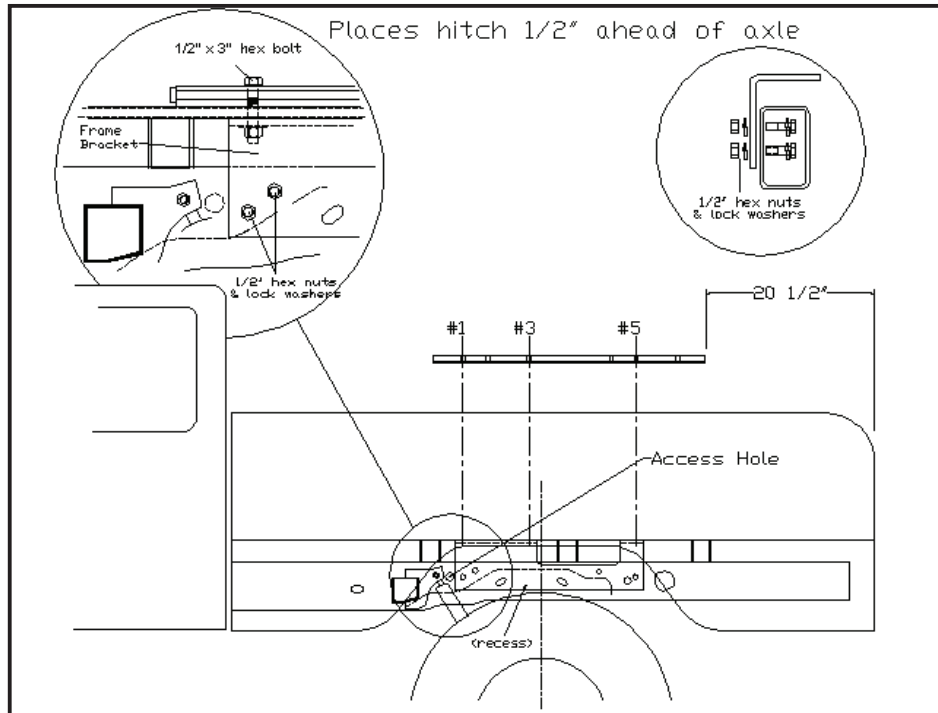

### INSTALLATION

1. a. Completely assemble hitch. See GENERAL INSTRUCTIONS and SAFETY supplied.  
b. Set hitch into back of truck, center it side to side.  
c. Measure 20 1/2" from back edge of truck box to back edge of bed rail.
2. Check underneath box at bolt hole locations for any obstructions (frame members, etc.).
3. a. Drill two 17/32" holes thru HOLE #1, each bed rail.  
b. Insert two 1/2" x 3" (04073) long hex bolts.  
c. Drill thru HOLES #3 and #5, each bed rail. Insert four 1/2" x 3" hex bolts (04073).
4. a. Under box, place (14189-76) frame brackets onto hex bolts (six places).  
b. Loosely install frame washer (14235-95), 1/2" flat washer (00085), and 1/2" Nylon lock nut (02178).  
c. Press each bracket tight against frame member, tighten nuts snug against box.
5. a. Pilot drill\* and drill 1/2" hole into truck frame, at four places thru holes in each frame bracket -- BE CAREFUL OF ELECTRIC OR FLUID LINES behind frame members.  
b. Brackets will be bolted onto frame by drilling frame and fishing knurl bolt (14266) through frame with fish wire (14238) and attach with 1/2" serrated flange nut (10379) on outside of bracket.  
c. TIGHTEN ALL BOLTS ACCORDING TO CHART ON FRONT PAGE.

\* To pilot drill: Use 1/2" drill bit or transfer punch to mark center. Drill thru with 1/4" drill.

# Demco

4010 320th St., BOYDEN, IA. 51234

PH: (712) 725-2311

FAX: (712) 725-2380

TOLL FREE: 1-800-54DEMCO (1-800-543-3626)

[www.demco-products.com](http://www.demco-products.com)

Go online to [www.demco-products.com](http://www.demco-products.com) for Demco warranty policies, operator manuals & product registration.