



Dodge Ram 1500  
5 1/2', 6 1/2' & 8' Box



**BOLT TORQUE SPECIFICATIONS**

STANDARD BOLTS			METRIC BOLTS		
Size	Grade	Torque	Size	Grade	Torque
5/16"	5	18 ft/lbs.	8mm	8.8	23 ft/lbs.
3/8"	5	30 ft/lbs.	10mm	8.8	45 ft/lbs.
7/16"	5	50 ft/lbs.	12mm	8.8	78 ft/lbs.
1/2"	5	75 ft/lbs.	14mm	8.8	125 ft/lbs.
5/8"	5	150 ft/lbs.			
3/4"	5	290 ft/lbs.			

# FRAME BRACKET

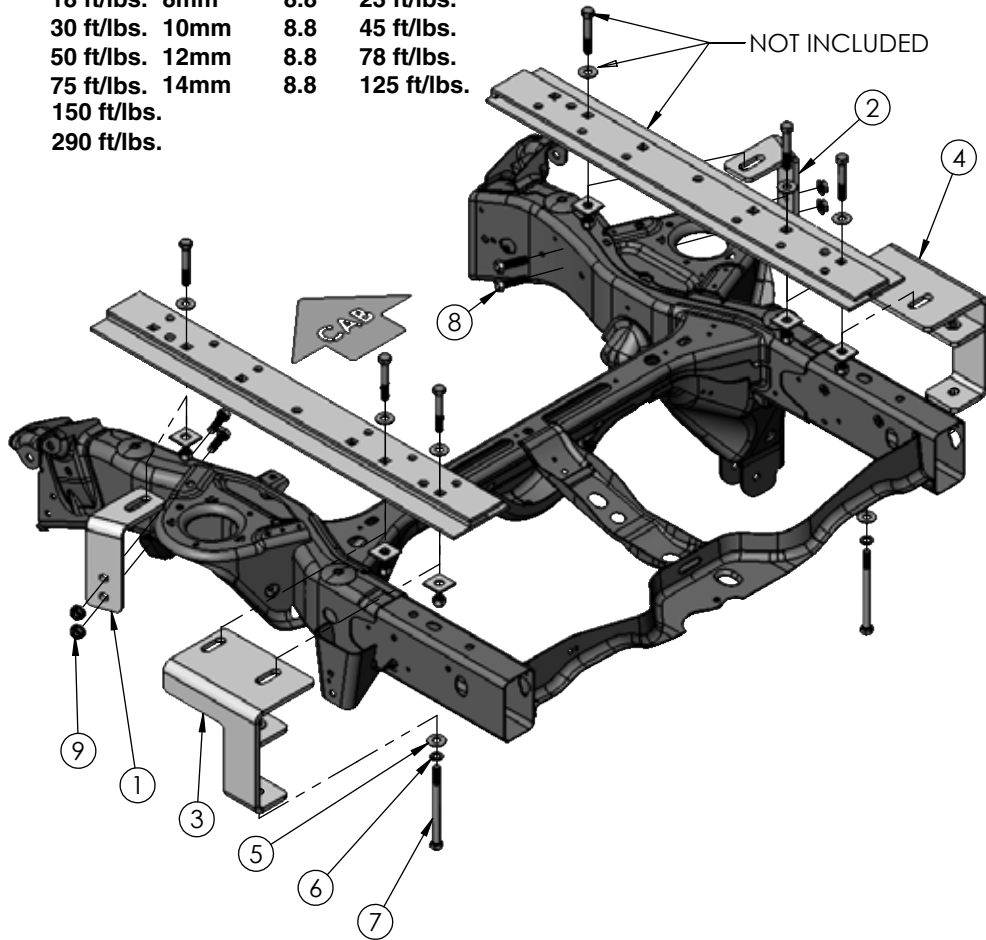

**8553010 PARTS LIST**

REF. NO.	PART NO.	QTY.	DESCRIPTION
1.	14239-76	1	Driver Side Front Frame Bracket
2.	14240-76	1	Passenger Side Front Frame Bracket
3.	14241-76	1	Driver Side Rear Frame Bracket
4.	14242-76	1	Passenger Side Rear Frame Bracket
5.	00085	2	1/2" Flat Washer
6.	00084	2	1/2" Lock Washer
7.	00349	2	1/2"-NC x 6" Hex Bolt Gr.5
8.	14266	4	1/2"-NC x 1-3/4" Hex Bolt Gr.5
9.	10379	4	1/2" Serrated Flange Nut

Please order replacement parts by **PART NO.** and **DESCRIPTION.**

ASSEMBLY  
OPERATION  
REPLACEMENT PARTS

**READ** complete manual CAREFULLY  
BEFORE attempting operation.

Doing Our Best to Provide You the Best

## WARRANTY POLICY, OPERATOR MANUALS & REGISTRATION

Go online to [www.demco-products.com](http://www.demco-products.com) to review Demco warranty policies, operator manuals and register your Demco product.

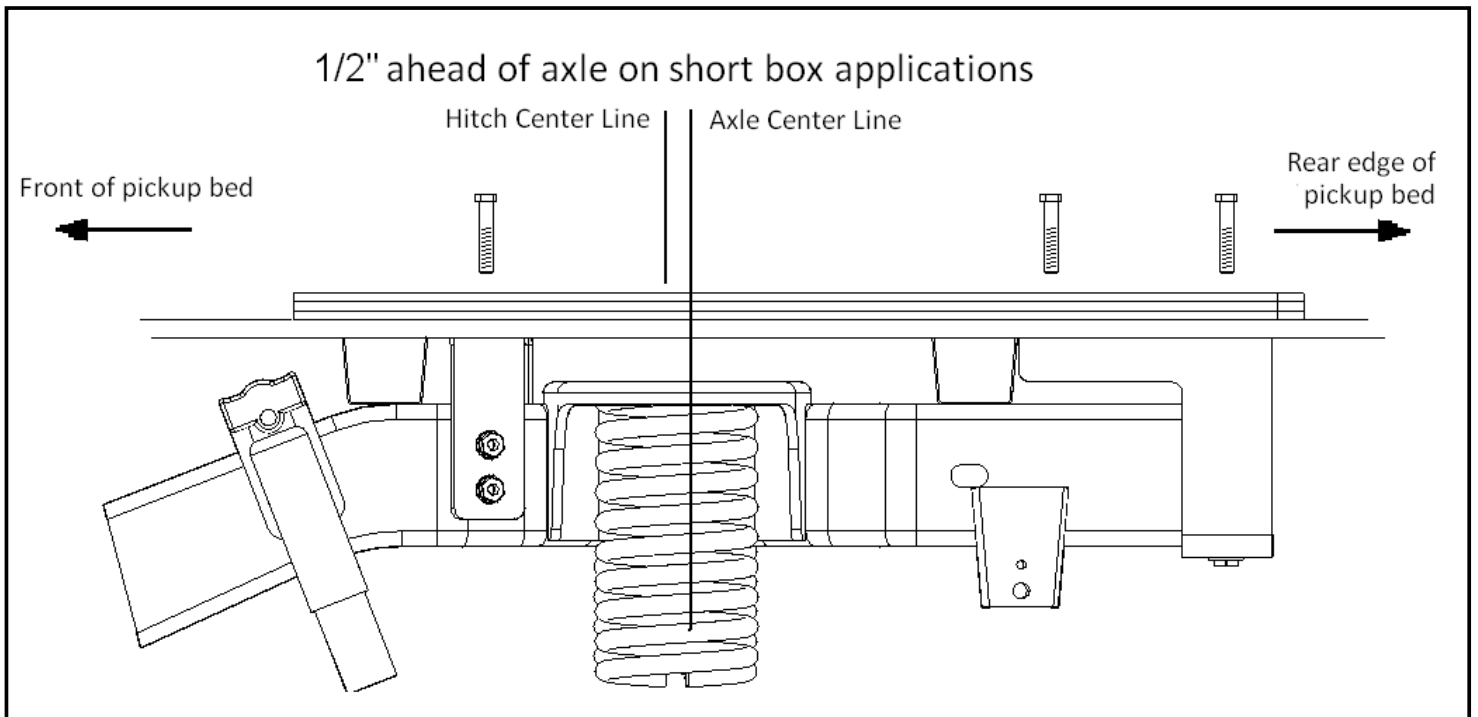

### ILLUSTRATION 1

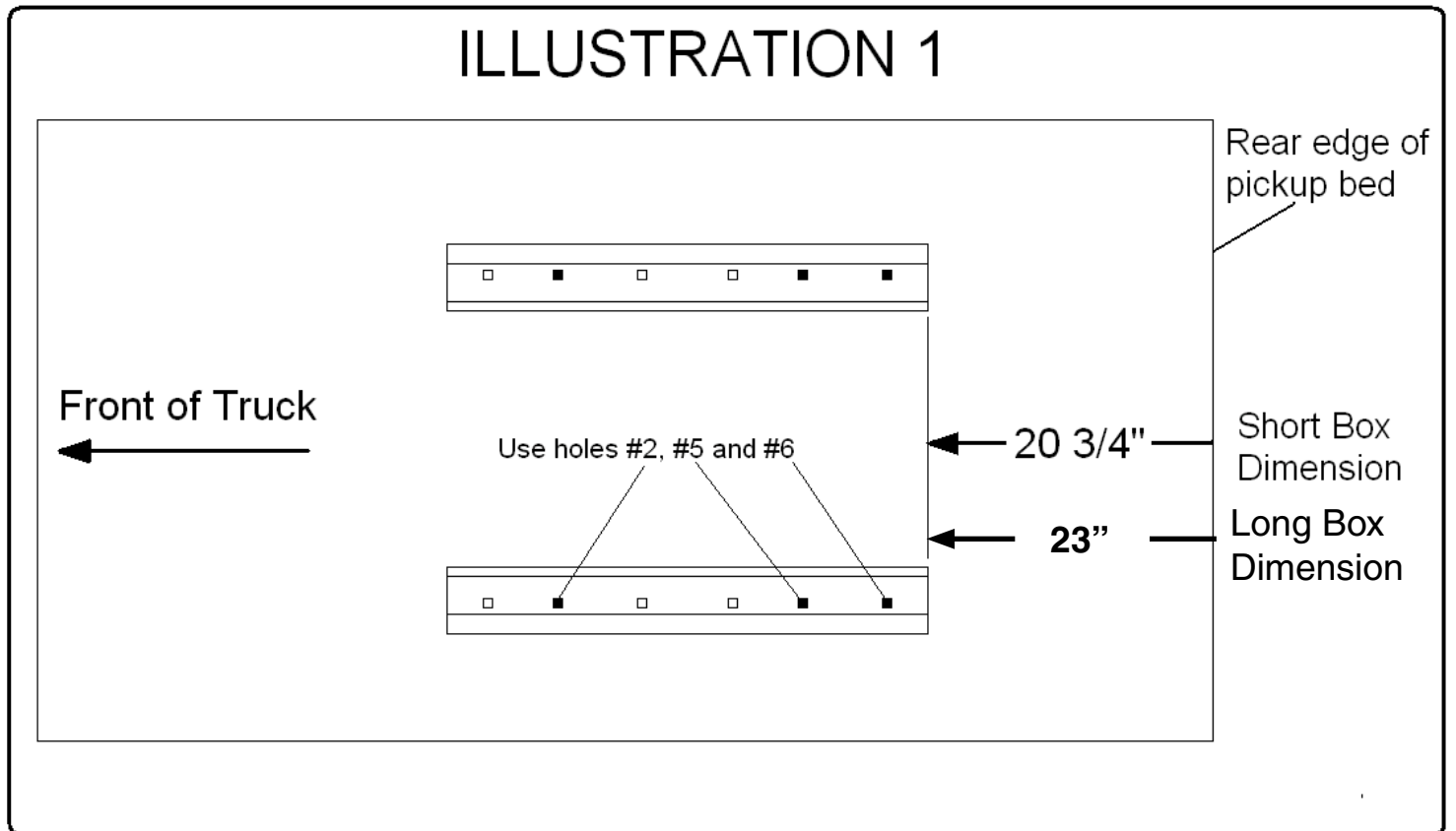

**CAUTION:** Do not install base rails over plastic bed liners. Plastic bed liners must be cut out of the way. Rails may be installed on spray in liners.

**NOTE:** Consult spray liner installer for recommended curing time.

1. Fully assemble the 5th wheel hitch on a flat, level surface and pin into the base rails (assembly instructions come with hitch components). Place assembled hitch in truck bed between the wheel wells, center it side to side and measure 20 3/4" from back edge of truck box to back edge of bed rail.
2. First check for obstructions under box, then drill two 17/32" hole thru hole #2 in each bed rail. Insert two 1/2" x 3" hex bolts.
3. Lift up spring loaded locking pins and slide hitch back to rear most set of holes and lock into place. This will help to align base rails so they remain square for best operation. Drill thru hole #6 and insert 1/2" x 3" bolts. Then do the same for hole #5 of each bed rail.
4. Position the left and right frame brackets us against the outer surface of the truck frame with the mounting tabs positioned over the frame and under the bed in line with previously drilled holes in bed where the 1/2" x 3" bolts are coming down through the bed.
5. Make sure the front brackets (hole #2) are tight against the flat side of the truck frame and underneath the surface of the truck bed with bolts extending down through slotted holes in frame bracket tabs. Fasten and tighten bolts with square washers and 1/2" lock nuts.
6. Using the holes in the front frame brackets as drill guides, drill two 17/32" holes in the side of the frame. Each of the front frame brackets (hole #2) must be attached to the side frame of the truck with two 1/2" x 1 3/4" hex knurl bolts (14266) and 1/2" flange nuts (10379) that are fished through an access hole in the frame using the fish wire provided in the kit. There is a large oval located on outside of frame a short distance forward of the bracket.
7. The rear frame bracket attaches to the frame by sliding it over the outside of the frame and using the 1/2" x 6" hex bolts (00349), 1/2" flat washers (00085), and 1/2" lock washer (00084) to secure to frame as shown below in Illustration 3.

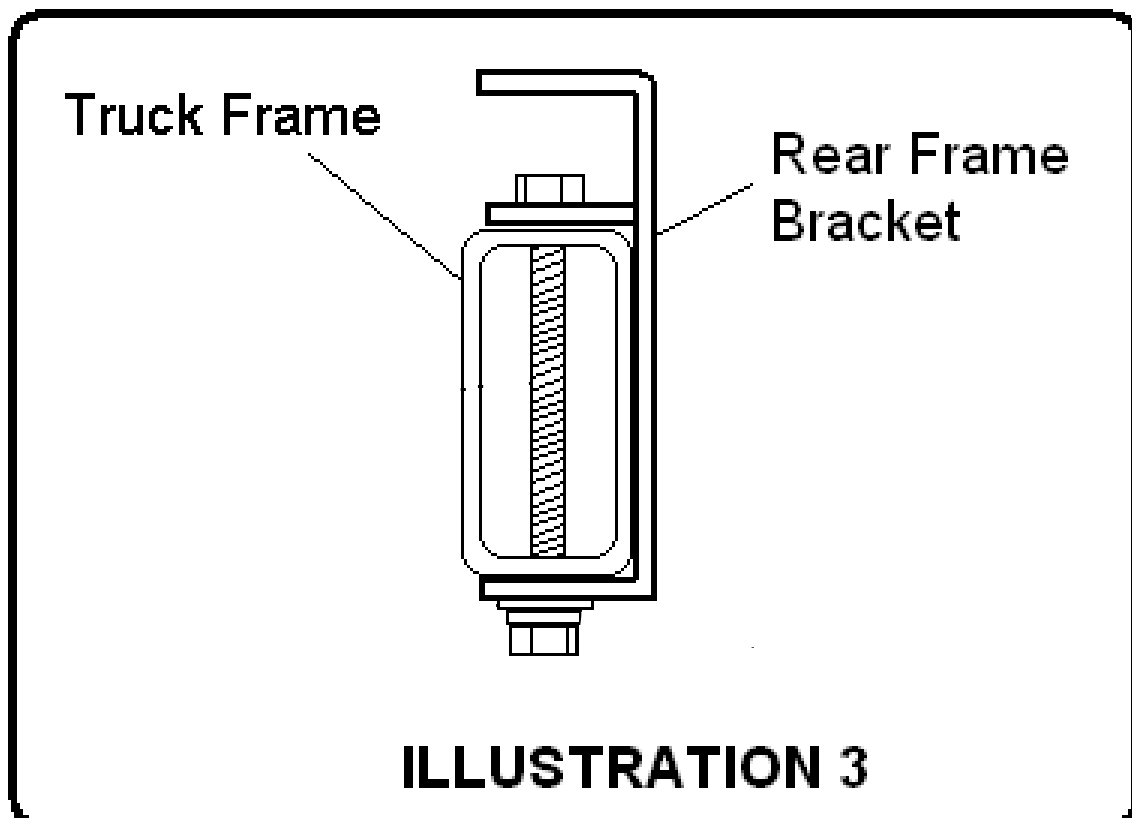

8. Tighten all bolts according to chart on front page. Failure to tighten bolts as described may result in fastener loss or failure.

*Demco*

4010 320th St., BOYDEN, IA. 51234

PH: (712) 725-2311

FAX: (712) 725-2380

TOLL FREE: 1-800-54DEMCO (1-800-543-3626)

[www.demco-products.com](http://www.demco-products.com)

Go online to [www.demco-products.com](http://www.demco-products.com) for Demco warranty policies, operator manuals & product registration.