



Dodge Ram 2500  
4x2 & 4x4  
6 1/2' & 8' Box  
Includes Mega Cab

9-15  
HJ33016, Rev 1



**BOLT TORQUE SPECIFICATIONS**

STANDARD BOLTS			METRIC BOLTS		
Size	Grade	Torque	Size	Grade	Torque
5/16"	5	18 ft/lbs.	8mm	8.8	23 ft/lbs.
3/8"	5	30 ft/lbs.	10mm	8.8	45 ft/lbs.
7/16"	5	50 ft/lbs.	12mm	8.8	78 ft/lbs.
1/2"	5	75 ft/lbs.	14mm	8.8	125 ft/lbs.
5/8"	5	150 ft/lbs.			
3/4"	5	290 ft/lbs.			

# FRAME BRACKET

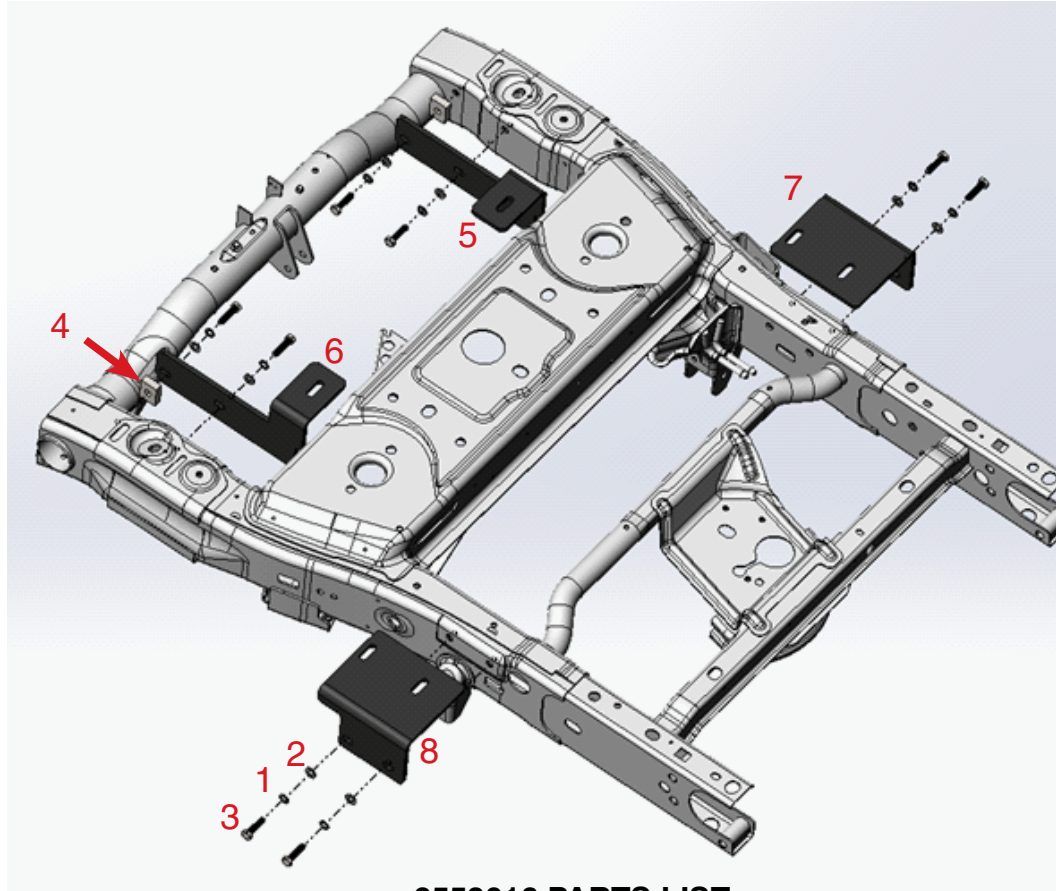

**8553016 PARTS LIST**

REF NO	PART NO	QTY	DESCRIPTION
1.	07288	8	12mm Lock Washer
2.	07432	8	12mm Flat Washer
3.	14854	8	12mm-1.5 x 45mm Hex Bolt Gr. 8.8
4.	14859-95	2	Spacer Block
5.	15373-76	1	Passenger Front Bracket
6.	15374-76	1	Driver Front Bracket
7.	15375-76	1	Passenger Rear Bracket
8.	15376-76	1	Driver Rear Bracket

**Please order replacement parts by PART NO. and DESCRIPTION.**

ASSEMBLY  
OPERATION  
REPLACEMENT PARTS

**READ** complete manual CAREFULLY  
BEFORE attempting operation.

Doing Our Best to Provide You the Best

## WARRANTY POLICY, OPERATOR MANUALS & REGISTRATION

Go online to [www.demco-products.com](http://www.demco-products.com) to review Demco warranty policies, operator manuals and register your Demco product.

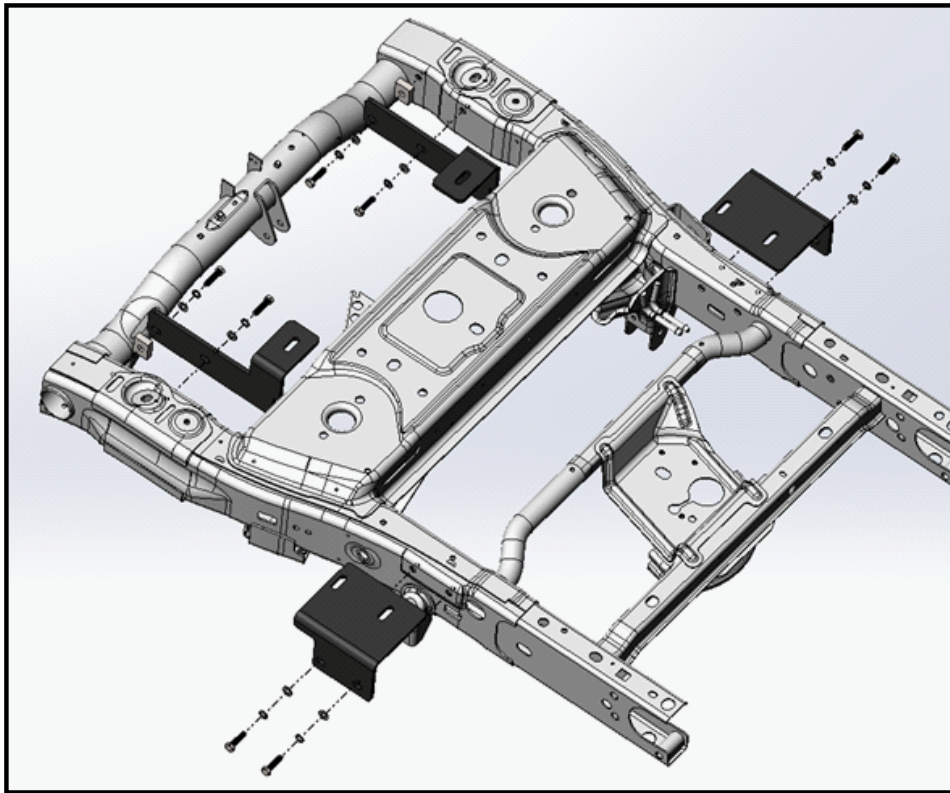

### INSTALLATION

1. a. Completely assemble hitch. See GENERAL INSTRUCTIONS and SAFETY supplied.  
b. Set hitch into back of truck, center it side to side.  
c. Measure 21" (6 1/2' Box) or 23" (8' Box) from back edge of truck box to back edge of bed rail.
2. Check underneath box at bolt hole locations for any obstructions (frame members, etc.).
3. a. Drill two 17/32" holes thru HOLE #2, each bed rail.  
b. Insert two 1/2" x 3" (04073) long hex bolts.  
c. Slide hitch to rear position, to parallel bed rails.  
d. Drill thru HOLES #5 and #6, each bed rail. Insert four 1/2" x 3" hex bolts (04073).
4. a. Under box, loosely install frame brackets, frame washer (14235-95), 1/2" flat washer (00085), and 1/2" Nylon lock nut (02178). **NOTE:** On drivers front bracket unclip wires/hoses from inside of frame to allow bracket to fit flush to frame. Front brackets are mounted to the inside of the frame and the rear brackets are mounted to the outside of the frame.  
b. Press each bracket tight against the frame member and using 12MM bolts (14854), 12MM lock washers (07288), and 12MM flat washers (07432) fasten each bracket to the frame using factory threaded hole in the frame. **NOTE:** On front brackets make sure to insert spacer block (14859-95) between frame and bracket on front hole location.  
c. **TIGHTEN ALL BOLTS ACCORDING TO CHART ON FRONT PAGE.** Fasten wires and brake lines back to inside of frame by driver side front bracket.

# Demco

4010 320th St., BOYDEN, IA. 51234

PH: (712) 725-2311

FAX: (712) 725-2380

TOLL FREE: 1-800-54DEMCO (1-800-543-3626)

[www.demco-products.com](http://www.demco-products.com)

Go online to [www.demco-products.com](http://www.demco-products.com) for Demco warranty policies, operator manuals & product registration.