



Doing Our Best to Provide You the Best

TB20060, Rev 0
01/19

SELF-ALIGNING TOW BAR

Commander II

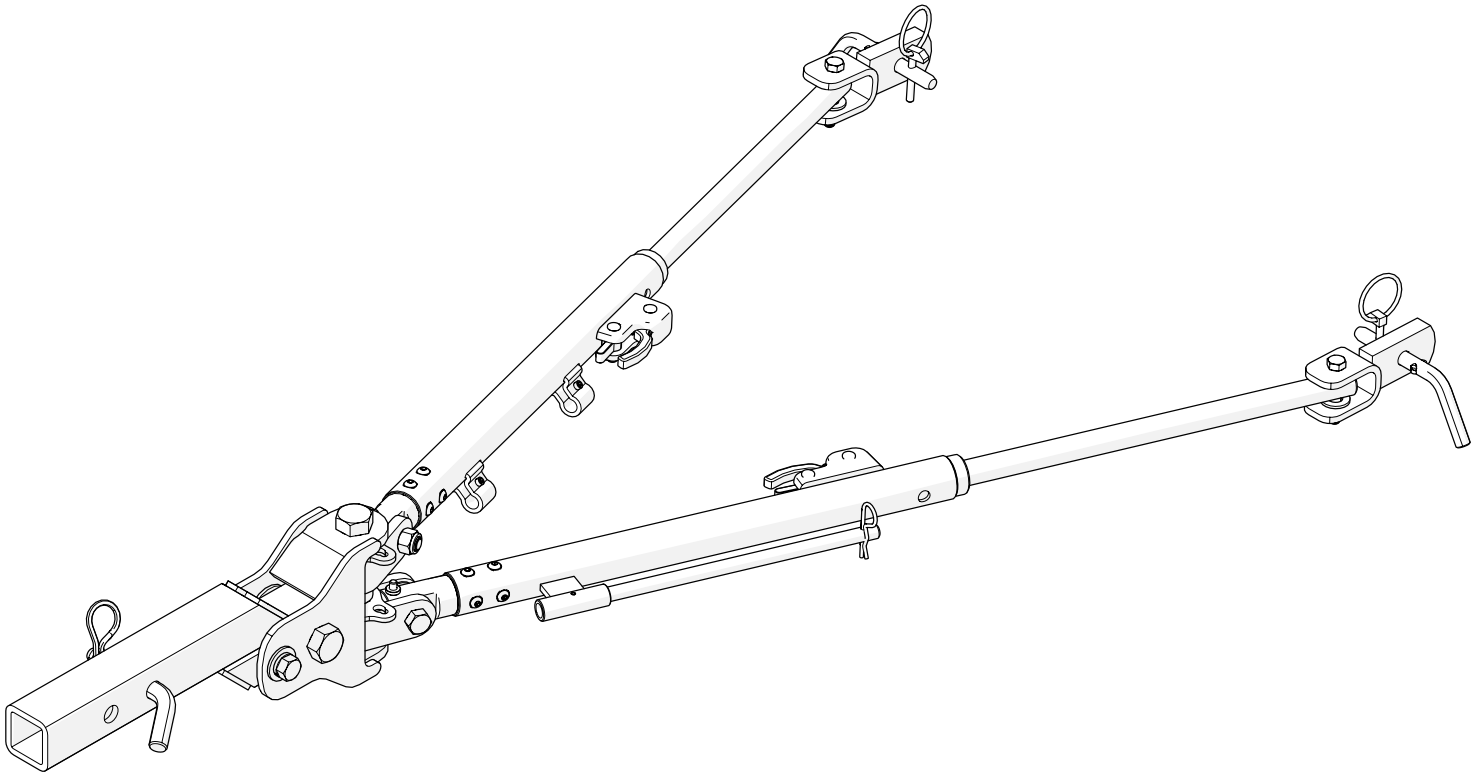

OPERATOR MANUAL

Warranty Policy, Operator Manuals & Registration

Go online to www.demco-products.com to review Demco warranty policies, operator manuals and register your Demco product.

⚠ WARNING: Exceeding weight limitations or not using a towing vehicle larger and at least 500 lbs. heavier than the tow bar and the towed vehicle combined can result in loss of towing vehicle control, separation of the tow bar from the towing vehicle, or separation of the towed vehicle from the tow bar, causing severe personal injury, death, and/or property damage.

TABLE OF CONTENTS

Warranty Policy, Operator Manuals & Registration.....	2
Equipment Safety Guidelines	3
Remember	3
Lighting and Marking.....	3
Safety Information	3
SAFETY Sign Locations	4
Safety Sign Care.....	4
Before operation.....	4
During Operation	5
Highway and Transport Operations	5
Following Operation	5
Performing Maintenance	6
Bolt Torque Data for Standard Nuts, Bolts, and Capscrews.....	7
Important Notice!	8
Latch Disassembly	9
Latch Reassembly	9
Hooking Up Tow Bar to Vehicle to Be Towed	10
Unhooking the Towed Vehicle	11
Receiver Parts Breakdown.....	12
Pivot Head Parts Breakdown.....	12
Connecting Leg Parts Breakdown	13
Connecting Legs to Pivot Head Parts Breakdown.....	14
Safety Cables.....	15
Safety Cable Extensions	15
4" or 6" Drop/Lift Receiver Hitch	16
Auxiliary Lighting Cable	16
3-Piece Locking Pins.....	17
Tow Bar to Base Plate Locking Pins.....	17
Light Bar.....	18

SAFETY

TAKE NOTE! THIS SAFETY ALERT SYMBOL FOUND THROUGHOUT THIS MANUAL IS USED TO CALL YOUR ATTENTION TO INSTRUCTIONS INVOLVING YOUR PERSONAL SAFETY AND SAFETY OF OTHERS. FAILURE TO FOLLOW THESE INSTRUCTIONS CAN RESULT IN INJURY OR DEATH.



**THIS SYMBOL MEANS
ATTENTION
BECOME ALERT
YOUR SAFETY IS INVOLVED!**

Signal Words

Note use of following signal words **DANGER**, **WARNING**, and **CAUTION** with safety messages. Appropriate signal word for each has been selected using following guidelines:

CAUTION:

Indicates a potentially hazardous situation that, if not avoided, may result in minor or moderate injury. It may also be used to alert against unsafe practices.

WARNING:

Indicates a potentially hazardous situation that, if not avoided, could result in serious injury or death, and includes hazards that are exposed when guards are removed. It may also be used to alert against unsafe practices.

DANGER:

Indicates an imminently hazardous situation that, if not avoided, will result in serious injury or death. This signal word is to be limited to the most extreme situations typically for tow bar components which, for functional purposes, cannot be guarded.

If you have questions not answered in this manual, or require additional copies, please contact your dealer or Demco, 4010 320th Street, Boyden, IA 51234, ph: (712) 725-2311 or (712) 725-2302, Toll Free: 1-800-543-3626 Fax: (712) 725-2380, <http://www.demco-products.com>



SAFETY...You can live with it

Equipment Safety Guidelines

Every year many accidents occur which could have been avoided by a few seconds of thought and a more careful approach to handling equipment. You, the operator, can avoid many accidents by observing and following precautions in this section. To avoid personal injury, study following precautions and insist those working with you, or you yourself, follow them.

Replace any caution, warning, danger or instruction safety decal that is not readable or is missing. Location of such decals is indicated in this booklet.

Do not attempt to operate this tow bar under the influence of alcohol or drugs.

Review safety instructions with all users.

Operator should be a responsible adult. **DO NOT ALLOW PERSONS TO OPERATE OR ASSEMBLE THIS TOW BAR UNTIL THEY HAVE DEVELOPED A THOROUGH UNDERSTANDING OF SAFETY PRECAUTIONS AND HOW IT WORKS.**

Do not paint over, remove, or deface any safety signs or warning decals on your tow bar. Observe all safety signs and practice instructions on them.

Never exceed limits of a tow bar. If its ability to do a job safely is in question **DON'T TRY IT.**

Remember

Your best assurance against accidents is a careful and responsible operator. If there is any portion of this manual or function you do not understand, contact your local authorized dealer or manufacturer.

Lighting and Marking

It is the responsibility of owner to know lighting and marking requirements of local highway authorities and to install and maintain equipment to provide compliance with regulations.

Light bar kits are available from your dealer or from manufacturer.

Safety Information

SAFETY Sign Locations

Types of safety sign and locations on the Commander II are shown in illustration below. Good safety requires that you familiarize yourself with various safety signs, type of warning, and particular function related to that area, that requires your SAFETY AWARENESS.

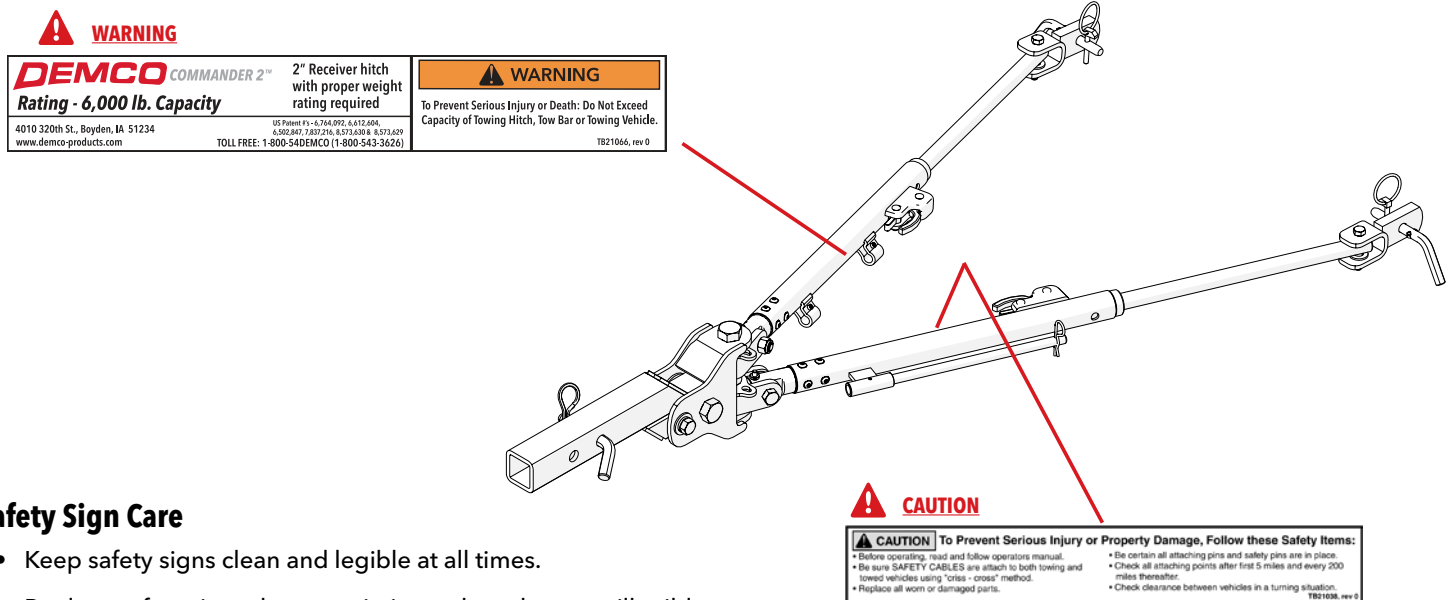

Safety Sign Care

- Keep safety signs clean and legible at all times.
- Replace safety signs that are missing or have become illegible.
- Replacement parts that displayed a safety sign should also display current sign.
- Safety signs are available from your distributor, dealer parts department, or factory.

How to install safety signs:

- Be sure installation surface is clean and dry.
- Decide on exact position before you remove backing paper.
- Remove smallest portion of split backing paper.
- Align decal over specified area and carefully press small portion with exposed sticky backing in place.
- Slowly peel back remaining paper and carefully smooth remaining portion of decal into place.
- Small air pockets can be pierced with a pin and smoothed out using piece of decal backing paper.

Before operation

- Carefully study and understand this manual.
- Give tow bar a visual inspection for any loose bolts, worn parts, or cracked welds, and make necessary repairs. Follow maintenance safety instructions included in this manual.
- Be sure there are no tools lying on tow bar, towing unit or towed vehicle.
- Do not use tow bar until you are sure that area is clear, especially around children and animals.
- Don't hurry learning process or take tow bar for granted. Ease into it and become familiar with your new tow unit.
- Practice operation of your tow unit and its attachments. Completely familiarize yourself and other operators with its operation before using.
- Securely attach to towing unit. Use an appropriately sized and rated hitch ball and/or a class III, class IV receiver and attach safety cables.
- Criss cross safety cables under tow bar, secure to mounting loops on towing vehicle.
- Do not allow anyone to stand between vehicles when backing up.
- Make sure tow rating on towing unit is high enough for what it is towing.
- To prevent swaying of towed vehicle insure all tires are inflated to specifications. Failure to inflate tires evenly will result in towed vehicle to pull unevenly.

During Operation

- Always follow state and local regulations regarding auxiliary lighting when towing. Be sure to check with local law enforcement agencies for your own particular regulations. Only safety cables (not elastic or nylon/plastic tow straps) should be used to retain connection between towing unit and towed vehicle in event of separation.
- Do not load towed vehicle with cargo. Towed vehicles exceeding weight limits will overload tow bar and may cause serious injury and damage.
- Beware of bystanders, **PARTICULARLY CHILDREN!** Always look around to make sure it is safe to start engine of towing unit and moving towed vehicle. This is particularly important with higher noise levels, as you may not hear people shouting.
- **NO PASSENGERS ALLOWED-** Do not carry passengers anywhere on or in towed vehicle.
- When halting operation, even periodically, set towing unit's parking brake, shut off engine, and **remove ignition key**.
- Be extra careful on inclines.
- **MANEUVER TOWING UNIT AT SAFE SPEEDS.**
- Avoid overhead wires or other obstacles. Contact with overhead lines could cause serious injury or death.
- Avoid loose gravel, rocks, and holes; they can be dangerous for unit operation or movement.
- Allow for unit length when making turns.
- Do not work under raised components or attachments unless securely positioned and blocked.
- Keep all bystanders and pets clear of work area.
- Operate towing unit from operators seat only.
- As a precaution, recheck hardware on tow bar every 200 miles, and correct all problems. Follow maintenance safety procedures.

Following Operation

- Following operation, or when unhooking, stop towing vehicle, set parking brake, shut off engine and **remove ignition key**.
- Store tow bar in area away from human activity.
- Do not permit children to play on or around stored tow bar.
- Make sure parked vehicle is on hard, level surface.
- Wheel chocks may be needed to prevent vehicle from rolling.

Highway and Transport Operations

- Adopt safe driving practices:
 - Always drive at safe speed relative to local conditions and ensure that your speed is low enough for an emergency stop.
 - Reduce speed prior to turns to avoid risk of overturning.
 - Always keep towing unit in gear to provide engine braking when going downhill. Do not coast.
 - Do not drink and drive!
- Comply with state and local laws governing highway safety.
- Local laws should be checked for all highway lighting and marking requirements.
- Plan your route to avoid heavy traffic.
- Be a safe and courteous driver. Always yield to oncoming traffic in all situations, including narrow bridges, intersections, etc.
- Watch for obstructions overhead and to both sides while towing vehicle.
- Operate with maximum visibility at all times. Make allowances for increased length and weight when making turns and stopping.

Safety Information

Performing Maintenance

- Good maintenance is your responsibility. Poor maintenance is an invitation to trouble.
- Make sure there is plenty of ventilation. Never operate engine of towing unit in a closed building. Exhaust fumes may cause asphyxiation.
- Before working on tow bar, stop towing vehicle, set parking brake, turn off engine and **remove ignition key**.
- Always use proper tools or equipment for job at hand.
- Use extreme caution when making adjustments.
- Follow torque chart in this manual when tightening bolts and nuts.
- After servicing, be sure all tools, parts and service equipment are removed.
- Do not allow grease or oil to build up.
- When replacing bolts, refer to owners manual.
- Refer to bolt torque chart for head identification marking.
- Where replacement parts are necessary for periodic maintenance and servicing, genuine factory replacement parts must be used to restore your tow unit to original specifications. Manufacturer will not claim responsibility for use of unapproved parts and/or accessories or other damages as a result of their use.
- If tow unit has been altered in any way from original design, manufacturer does not accept any liability for injury or warranty.
- A fire extinguisher and first aid kit should be kept readily accessible while performing maintenance on this tow bar.
- Any disassembly of the Commander II must be performed by an authorized dealer or sent back to Demco for repair and maintenance.

Bolt Torque Data for Standard Nuts, Bolts, and Capscrews

Tighten all bolts to torques specified in chart unless otherwise noted. Check tightness of bolts periodically, using bolt chart as guide. Replace hardware with same grade bolt.

NOTE: Unless otherwise specified, high-strength Grade 5 hex bolts are used throughout assembly of equipment.

Torque figures indicated are valid for non-greased or non-oiled threads and heads unless otherwise specified. Therefore, do not grease or oil bolts or capscrews unless otherwise specified in this manual. When using locking elements, increase torque values by 5%.

* GRADE or CLASS value for bolts and capscrews are identified by their head markings.

Bolt Torque for Standard bolts *

"A"	GRADE 2		GRADE 5		GRADE 8	
	lb-ft (N.m)	lb-ft (N.m)	lb-ft (N.m)	lb-ft (N.m)	lb-ft (N.m)	lb-ft (N.m)
1/4"	6 (8)	9 (12)	12 (16)			
5/16"	10 (13)	18 (25)	25 (35)			
3/8"	20 (27)	30 (40)	45 (60)			
7/16"	30 (40)	50 (70)	80 (110)			
1/2"	45 (60)	75 (100)	115 (155)			
9/16"	70 (95)	115 (155)	165 (220)			
5/8"	95 (130)	150 (200)	225 (300)			
3/4"	165 (225)	290 (390)	400 (540)			
7/8"	170 (230)	420 (570)	650 (880)			
1"	225 (300)	630 (850)	970 (1310)			

Bolt Torque for Metric bolts *

"A"	CLASS 8.8		CLASS 9.8		CLASS 10.9	
	lb-ft (N.m)	lb-ft (N.m)	lb-ft (N.m)	lb-ft (N.m)	lb-ft (N.m)	lb-ft (N.m)
6	9 (13)	10 (14)	13 (17)			
7	15 (21)	18 (24)	21 (29)			
8	23 (31)	25 (34)	31 (42)			
10	45 (61)	50 (68)	61 (83)			
12	78 (106)	88 (118)	106 (144)			
14	125 (169)	140 (189)	170 (230)			
16	194 (263)	216 (293)	263 (357)			
18	268 (363)	--	364 (493)			
20	378 (513)	--	515 (689)			
22	516 (699)	--	702 (952)			
24	654 (886)	--	890 (1206)			

Torque all 1/4" button head screws to 6 ft/lbs and apply Blue *LOCTITE*® to threads.

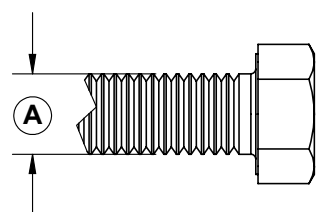

GRADE-2

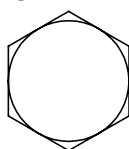

GRADE-5

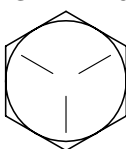

GRADE-8

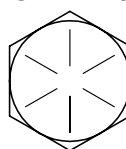

CLASS 8.8

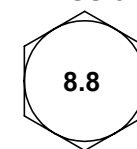

CLASS 9.8

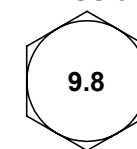

CLASS 10.9

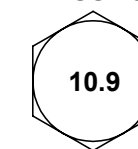

Important Notice

Important Notice!

Be sure towed vehicle is suitable or adaptable for towing.

A few models are not towable!

Be sure to check if towed vehicle requires additional equipment such as a transmission lube pump, free-wheel hubs, driveline disconnect or axle locks. Failure to properly equip towed vehicle will result in severe damage to towed vehicle's transmission.

Be sure that towed vehicle's steering wheel is unlocked and free to turn. Check manufacturer's specifications for the proper way to unlock steering wheel.

Be sure to check that receiver on towing vehicle is not inset too far. When attaching a Demco towing product it is important that turning clearance is adequate. A receiver that is inset too far on a towing vehicle will shorten turning radius. Failure to check this may result in towing or towed vehicle to be damaged. It may be necessary to install a receiver extension to allow for proper turning clearance.

⚠ WARNING: FAILURE TO FOLLOW THESE INSTRUCTIONS CAN RESULT IN LOSS OF TOWING VEHICLE CONTROL, SEPARATION OF THE TOW BAR FROM THE TOWING VEHICLE, SEPARATION OF THE TOWED VEHICLE FROM THE TOW BAR, CAUSING SEVERE PERSONAL INJURY, DEATH, OR PROPERTY DAMAGE.

⚠ WARNING: ADDITIONAL SAFETY ITEMS
Safety is of utmost importance at all times. To prevent personal injury or property damage, observe the following.

- Before allowing anyone to hook up or operate the Commander II, be sure they have read and understand the proper operating procedure.

- This unit must be used with a Class III, 5,000 lb. Hitch or higher.

- Be sure the steering components of the towed vehicle are properly aligned.

- The male receiver tube must fit snugly in the hitch receiver and the safety pin must be in position to lock the receiver and tube together.

- **NOTE:** Any severe backwards cornering could result in damage to the Commander II and/or towed vehicle chassis.

- **For automatic transmissions:** Consult your vehicle owners manual for towing suitability with the drive shaft connected. Otherwise, the towed vehicle will have to be equipped with a transmission pump or drive shaft disconnect.

- Be sure the **SAFETY CABLES w/retainers** are hooked to both the towing and towed vehicles using the crisscross method.

- Do not load the towed vehicle with anything as you may exceed the towing capacity of the tow bar.

- Check to make sure that all lights are in proper working order.

- Make sure the optional light bar is fastened securely at the rear of the towed vehicle.

- Do not use coiled safety cables with this tow bar, always use straight Demco safety cables.

MAINTENANCE

Periodically check all bolts and nuts to ensure proper tension or torque.

Check all pivot points for wear or breakage.

Replace any worn or damaged parts with O.E.M. parts only.

An occasional spray of lubricant may be required inside the latch trigger area of the extending legs.

DO NOT lubricate any of the pivot points of the Commander II. These are self-lubricating washers and your towbar could lose its self-supporting ability.

Keep the Commander II covered when stored on or off the towing vehicle.

If the Commander II needs servicing, only an authorized dealer can service it or it can be sent to Demco for servicing.

Make sure all bolts are properly tightened and those requiring a set torque are up to specifications:

Thank you for Purchasing **DEMCO** Products.

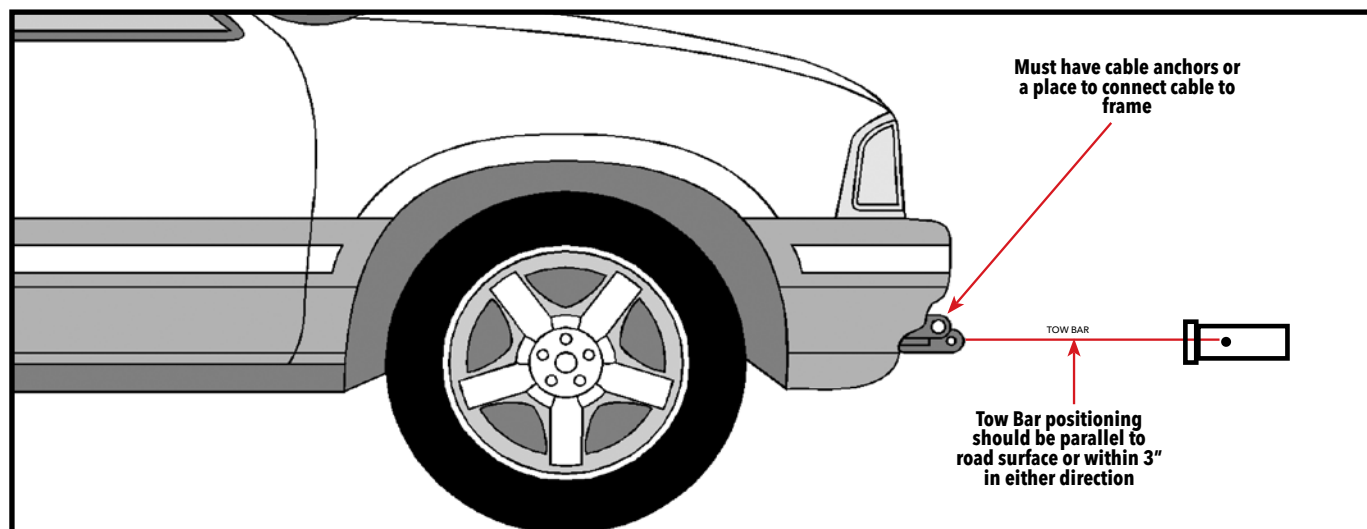

Latch Disassembly

You may leave the Commander II in the hitch receiver or take it out and work on it on a work bench.



1. Collapse the connecting leg all the way in. With a straight screwdriver, remove two E-clips from latch assembly pins and remove pins.



2. Remove trigger latch, latch sear and spring from bottom side of latch housing. Clean and inspect parts for wear and damage. Replace worn & damaged parts.

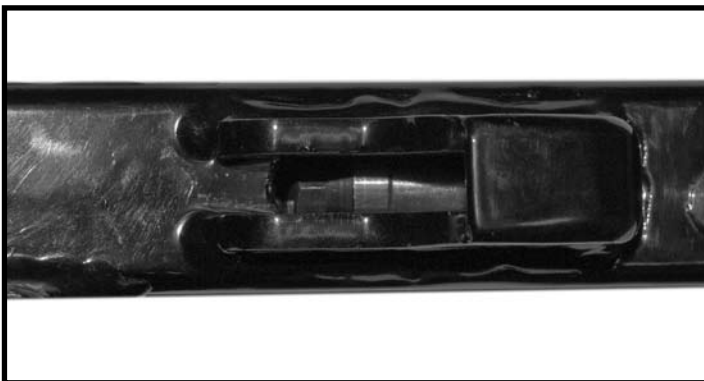

3. Slide connecting leg shaft so you can see latch washer through latch opening, and inspect latch sear washer through slot in rail tube, for dirt, wear or damage.

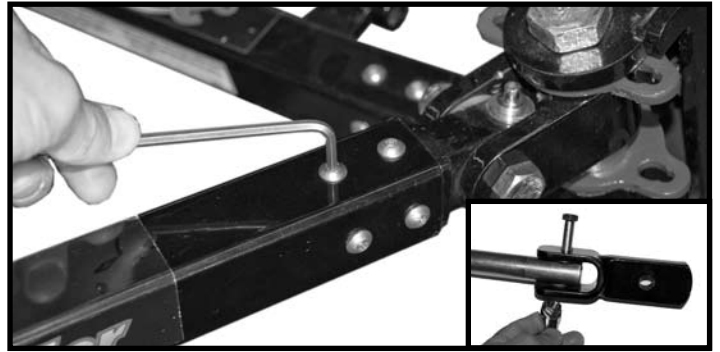

4. If sear washer has excessive dirt or wear, the shaft will need to be removed. Remove connecting clevis from shaft, note location of washers. Remove eight fasteners from receiver end of connecting leg and slide rail tube off of front clevis adaptor and slide shaft out of tube.



5. Clean shaft and connecting leg assembly, replace worn or damaged parts. Repeat process for other connecting leg. **NOTE:** Keeping matching side together for reassembly.

Latch Reassembly

NOTE: Apply Blue **LOCTITE**® to all fasteners and torque fasteners according to the torque chart on page 7. **Torque the 1/4" button head screws to 6 ft/lbs.**

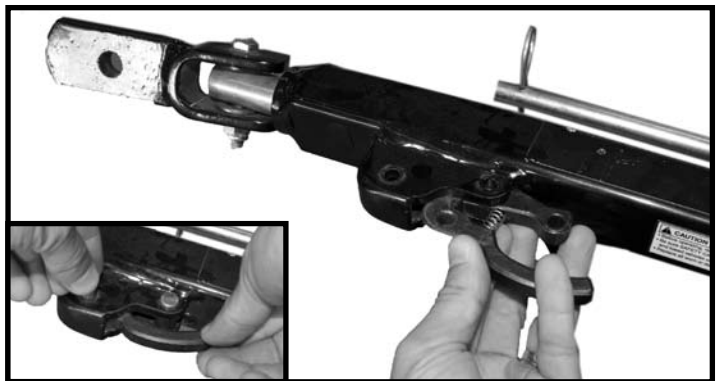

1. Reinstall connecting leg shaft and push shaft all the way in to reinstall latch assembly. Install latch as an assembly, put pin on bottom latch sear hole first and the latch trigger handle second. Hold the trigger handle down like you are releasing the latch to aid in getting the 5/16" pin in. Be sure to install e-clips on pins.
2. Reassemble the rest of the tow bar in reverse order as the disassembly.

Tow Bar Instructions

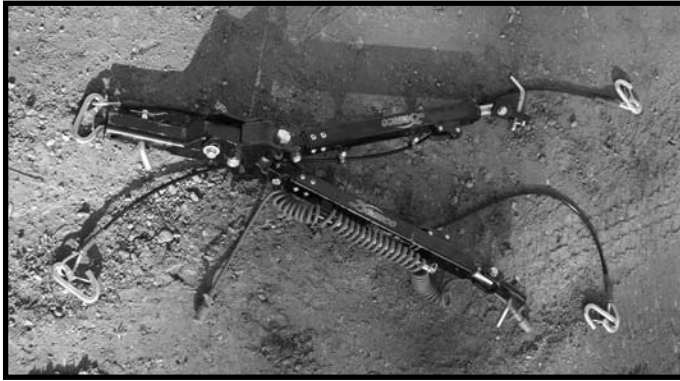

Step 1. Out of the box, the Commander II tow bar is setup with the safety cables install, ready for you to tow. Install the light cable (optional) by placing the coil over the wire support rod. Secure the cable with the cable locking hair pin.

Hooking Up Tow Bar to Vehicle to Be Towed

Refer to load limits on inside of front cover.



Step 2. Insert the Commander II into a Class III or IV hitch.



Step 3. Insert receiver pin through receiver until pin passes through. Secure pin with the Receiver hair pin. Crisscross safety cables underneath pivot assembly and attach to chain anchors on towing vehicle. Do not use coiled safety cables with this tow bar, always use straight Demco safety cables.

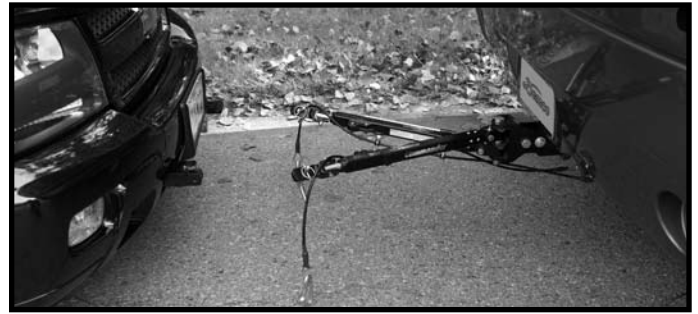

Step 4. Position the vehicle to be towed approx. 24" behind the towing vehicle. Perform a tow bar check, look for any loose fasteners, condition of safety cables, excessive movement in connecting leg shaft when the shaft is extended and locked. If any excessive movement or loose fasteners, the tow bar will need to be serviced before towing. The vehicles **do not** have to be in straight alignment to complete the hook-up. **Engage towed vehicle and towing vehicle parking brake.**



Step 5. Slide and twist the legs into position to attach them to the baseplate on towed vehicle. Secure to baseplate using the two attaching pins and 1/4" quick-lock pin. Attach safety cables (see below). Now connect the lighting cable between the towing vehicle and the towed vehicle lighting system or optional light bar. The coiled section of the cable will be stored on the support rod. **Towing vehicle must be larger and at least 500 lbs. heavier than the towed vehicle and tow bar combined.**

Step 6. Hook safety cables to chain anchor of baseplate. **Note:** Make sure safety clip is in working order.

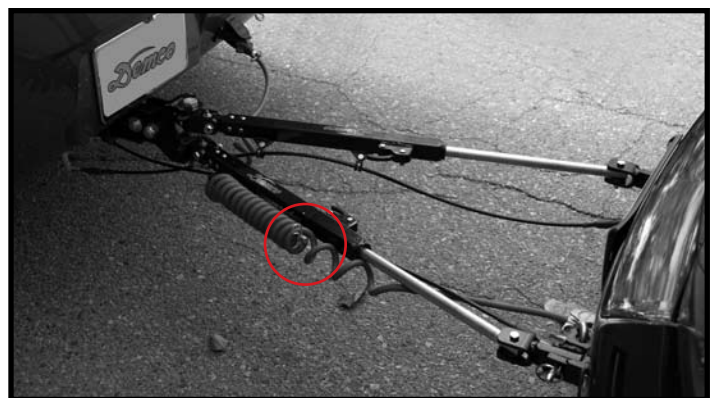

Step 7. Leave the electrical cable storage pin (circled above) out for the locking procedure in step 6. When step 6 is completed, position cable on storage rod leaving enough slack, and insert pin.



Quick-Lock pin must be closed properly. Fold ring of Quick-Lock Pin to the side of the pin that allows ring to snap against pin. If you have folded its ring the wrong way it will not snap against pin.

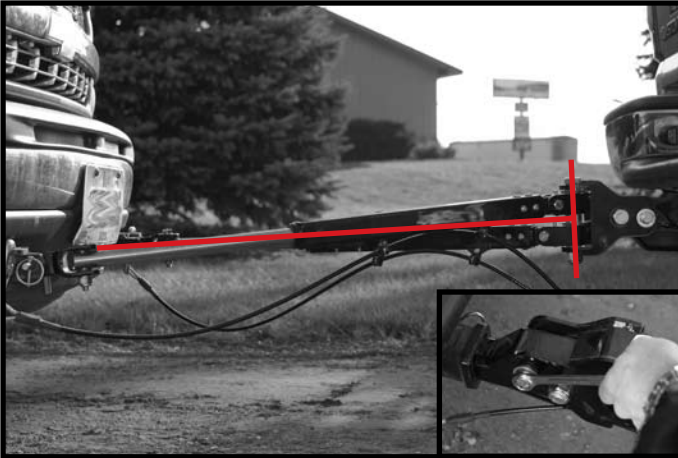

Step 8. Once you are secured to the tow bar, release towed vehicle parking brake, and slowly back up the towed vehicle straight back until one leg latches. Determine which leg latched by having an assistant tell you. If you are by yourself put towed vehicle in neutral or park, and apply parking brake. Get out and check to see which leg latched. To latch the second leg, turn the top of towed vehicle's steering wheel into the direction of the leg that first latched, and slowly back up again. This will latch the second leg. Once both legs are latched, straighten wheels on towed vehicle, shut vehicle off. Adjust tow bar receiver head so the vertical bolt is perpendicular to the baseplate height of towed vehicle. **Tighten the 1/2" bolts on each side of joint head to 85 ft/lbs.** If manual transmission, shift to neutral, unlock steering wheel and make sure parking brake is released. **Note: For four wheel drive units, shift transfer case into neutral also. Reminder:** Consult vehicle's manufacturer for towing suitability of manual or automatic transmission vehicles.

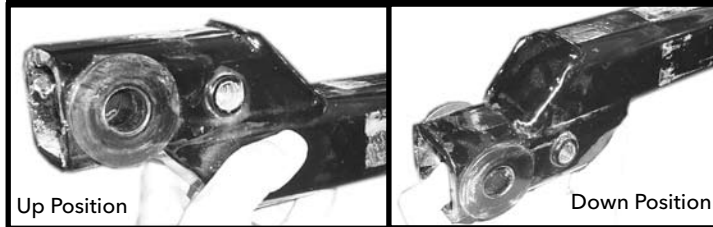

NOTE: The Commander II comes with a 1-1/2" off-set receiver that can be flipped to help level the tow bar with the towed vehicle. The receiver is in the down position from factory, to change to the lower position, remove both 1/2" bolts and washer from side of receiver joint head. Remove the 3/4" nut and bolt, slide receiver out of receiver joint head and flip receiver into the down position. Slide receiver back into the receiver joint head and reinstall the fasteners.

Unhooking the Towed Vehicle

Step 1. Begin unhooking your unit by first applying both vehicle parking brakes and unhook your lighting and safety cables. **Failure to have parking brakes applied could allow towed vehicle to roll forward. This could result in limited space between towing vehicle and towed vehicle.**



Step 2. Use the latch trigger handle to release the connecting legs between the two vehicles by pressing down on the latch trigger handle.

Step 3. Remove pins that attach tow bar to towed vehicle. Commander II will remain in position. Slide the extendable legs back into tube. Position electrical cable on storage rod and insert pin to prevent cable from sliding off.

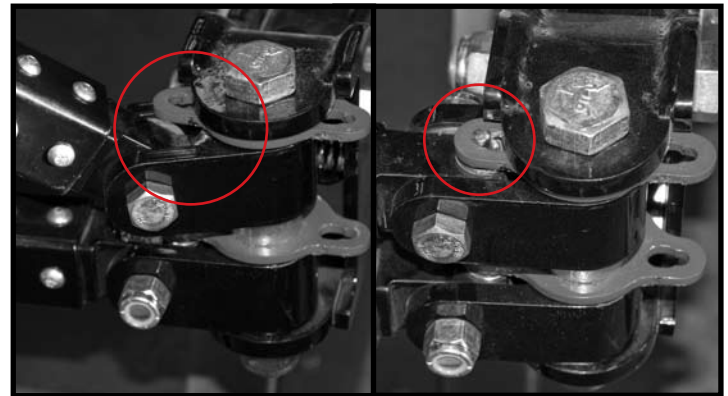

Step 4. Now take the bottom leg and lift up high enough for storage pin to clear under storage plate. Turn leg under storage and push leg down so pin locks into plate. Repeat for top leg.

NOTE: Your Commander II can store in three storage positions, both arms left, both arms right and one arm left and one arm right.

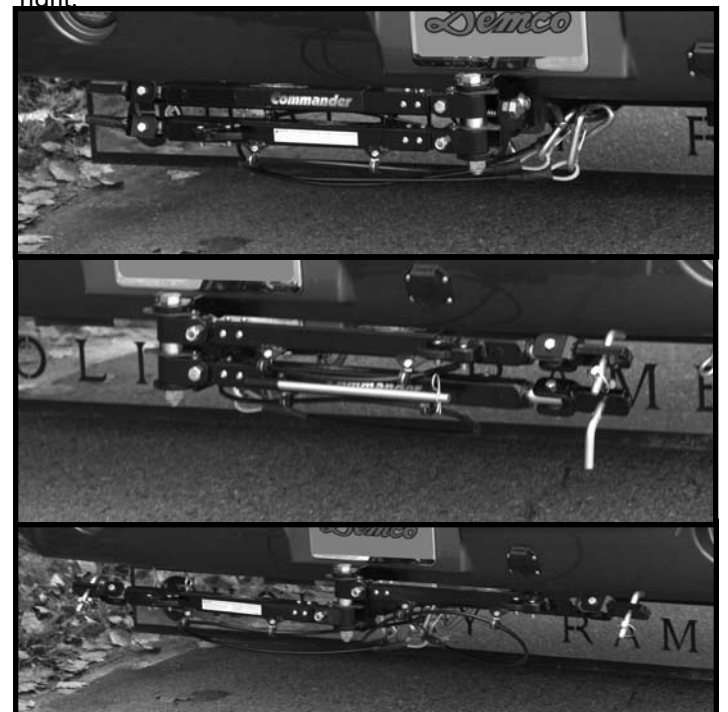

Parts Breakdown

Receiver Parts Breakdown

ITEM #	PART #	DESCRIPTION	Qty
1	00084	.50 LOCKWASHER	2
2	00085	.50 FLAT WASHER	2
3	00967	BOLT .50NC X 1.25 GR5 HEX	2
4	02961	.75NC NYLON INSERT LOCK NUT	1
5	07248	RECEIVER PIN	1
6	07251	HAIRPIN, RECEIVER PIN	1
7	13169	RECEIVER JOINT	1
8	13297	BOLT, .75 NC X 3.75 W/ 2.50 SHANK	1
9	13570	TOW BAR RECEIVER, 1.5 DROP/RISE	1
10	13168	CROSTUBE BUSHING, NYLATRON	2

Please order replacement parts by PART NO. and DESCRIPTION.

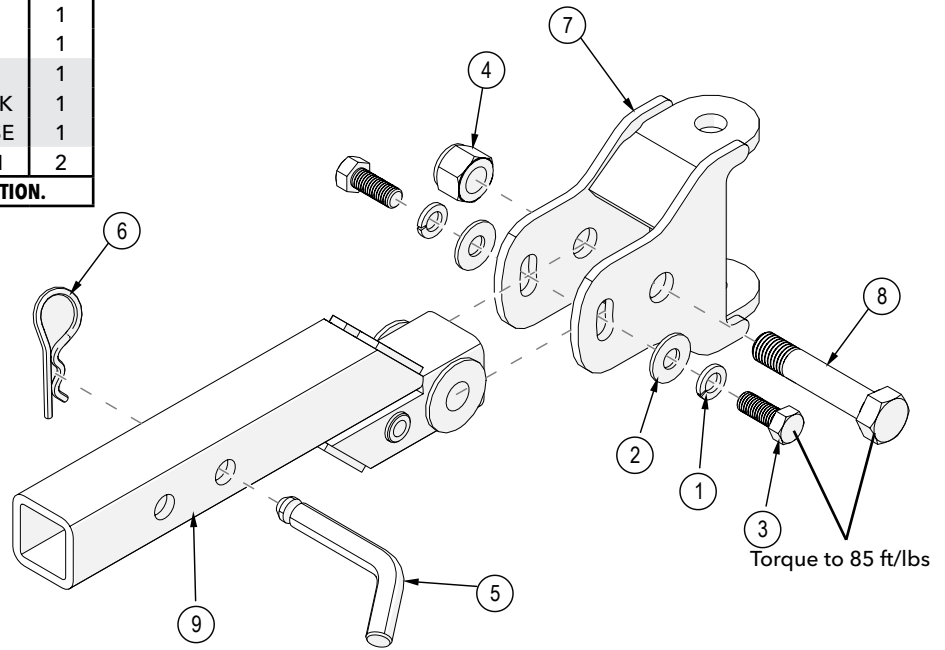

Pivot Head Parts Breakdown

ITEM #	PART #	DESCRIPTION	Qty
1	01964	BOLT .75NC X 7.00 GR5 HEX	1
2	02534	WASHER, MACHINE, .75 X 14GA	1
3	02961	.75NC NYLON INSERT LOCK NUT	1
4	13171	ALUMINUM CLEVIS	2
5	13228	FLANGED BUSHING, .75 ID	4
6	13571	SPRING, COMPRESSION	2
7	13589	STORAGE PLATE, SPRING LOADED	2
8	13590	SPACER	1

Please order replacement parts by PART NO. and DESCRIPTION.

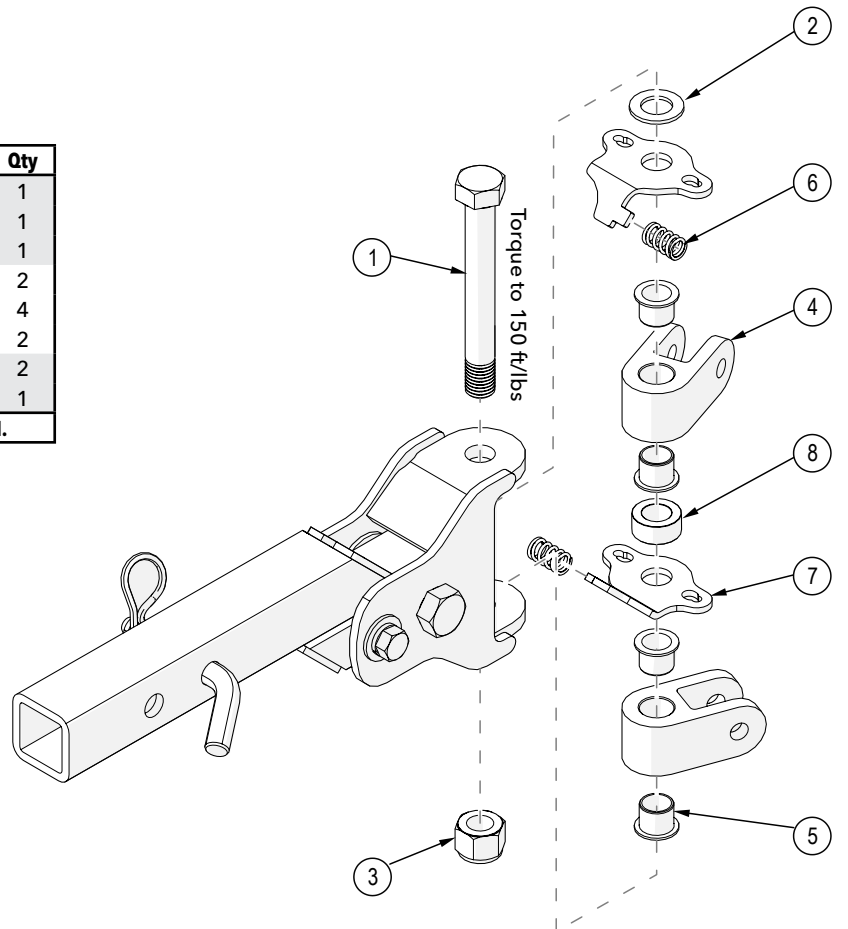

US Patent #'s - 6,764,092, 6,612,604, 6,502,847, 7,837,216, 8,573,630 & 8,573,629

Connecting Leg Parts Breakdown

Before Towing, perform a tow bar safety check, look for any loose fasteners, condition of safety cables, excessive movement in connecting leg shaft when the shaft is extended and locked. If any excessive movement or loose fasteners are found, the tow bar will need to be serviced before towing. If tow bar needs servicing, please bring it to an authorized dealer or send it to Demco.

ITEM #	PART #	DESCRIPTION	Qty
1	00182	HAIR PIN, .120 WIRE X 2.375	1
2	02397	LYNCH PIN	2
3	02592	NUT, .375NC NYLON LOCK	2
4	03805	WIRE SUPPORT ROD	1
5	03809	CLEVIS SPACER WASHER	4
6	03878	ATTACHING PIN	2
7	07223	ROLL PIN, .156 X .75	1
8	13176	TRIGGER HANDLE	2
9	13179	COMPRESSION SPRING	2
10	13185	SCREW, SOCKET BUTTON, .25 -20 X .50 SS	16
11	13227	PLASTIC BUSHING, .50 ID X .75 LG	2
12	13249	CLEVIS GROOVED PIN, .313 X 1.25, SS	4
13	13250	RETAINING RING F/ .313 SHAFT	4
14	13431	STORAGE PIN	2
15	13432	RETAINING E-CLIP, SS F/ .25 SHAFT	2
16	13572	CLEVIS BOLT, .375 NC X 2.25 LG, 1.50 SHANK	2
17	13582	CONNECTING CLEVIS F/Commander II	2
18	13859	LATCH SEAR	2
19	15713	CONNECTING SHAFT, Commander II	2
20	16699	CONNECTING LEG TUBE, LEFT	1
21	16700	CONNECTING LEG TUBE, RIGHT	1
22	16701	FRONT ADAPTOR	2

Please order replacement parts by PART NO. and DESCRIPTION.

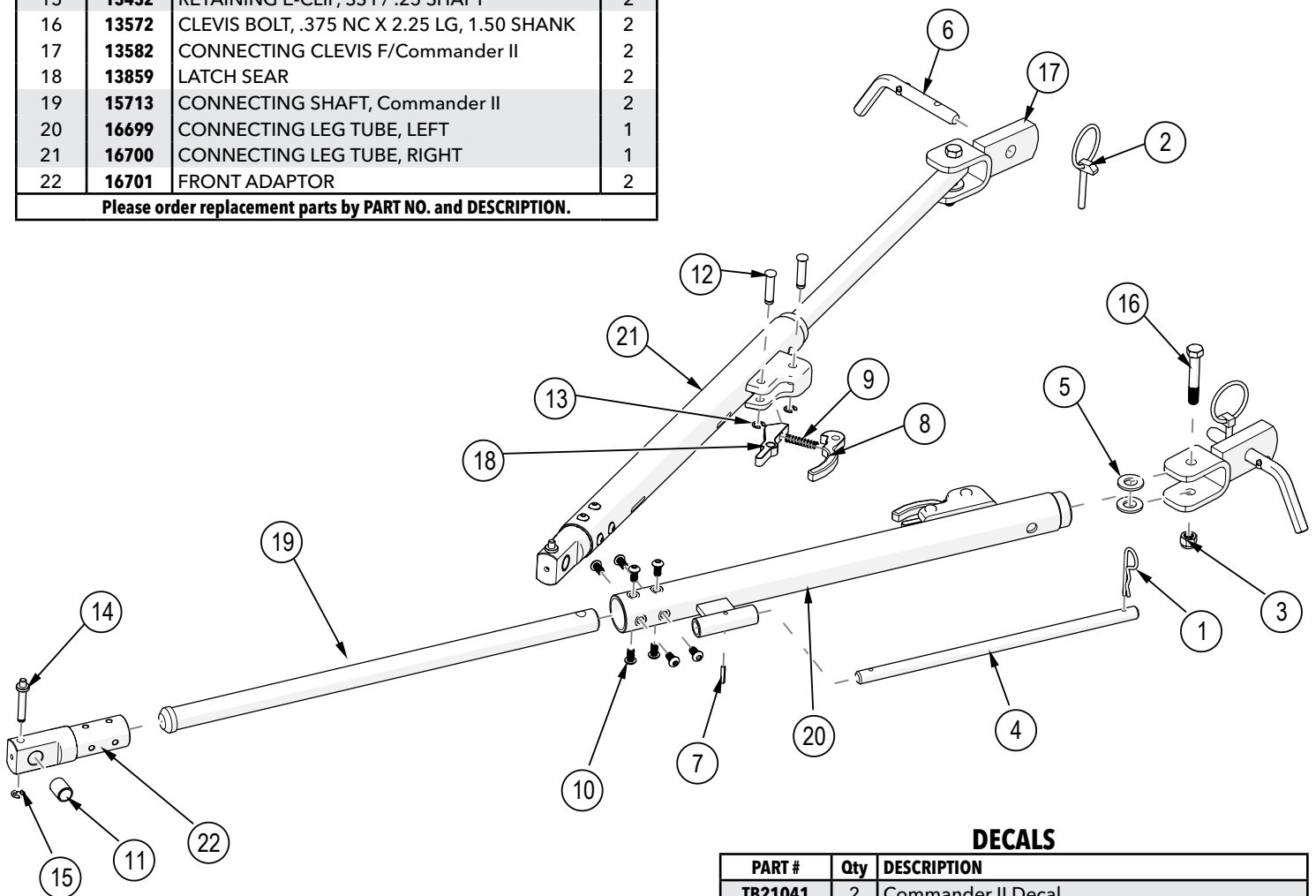

DECALS

PART #	Qty	DESCRIPTION
TB21041	2	Commander II Decal
TB21038	1	User Instruction Decal
TB21042	1	Warning Do Not Exceed Weight Limits & Manufacturers Patent / Hitch Rating Decal

Please order replacement parts by PART NO. and DESCRIPTION.

Parts Breakdown

Connecting Legs to Pivot Head Parts Breakdown

ITEM #	PART #	DESCRIPTION	Qty
1	02178	NUT, .50NC LOCK, NY. INSERT	2
2	13212	RAIL CLIP HOLDER	4
3	13213	SCREW, SOCKET HD, #8-32 X .625 SS	4
4	13273	SAFETY CABLE 54"	2
5	13305	BOLT, .50NC X 2.38 W/1.75 SHANK SS	2
6	13317	CLEVIS SPACER WASHER	4

Please order replacement parts by PART NO. and DESCRIPTION.

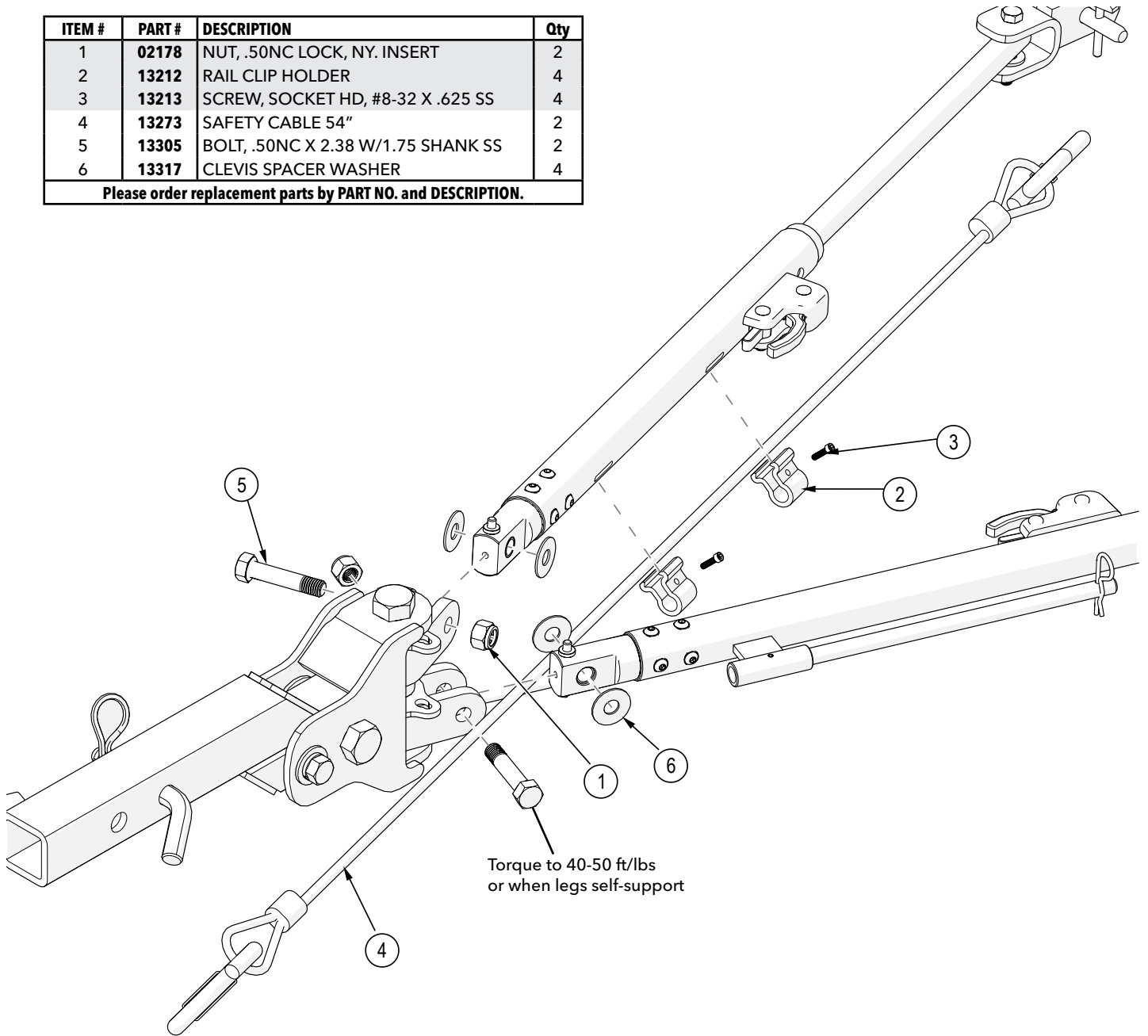

Safety Cables

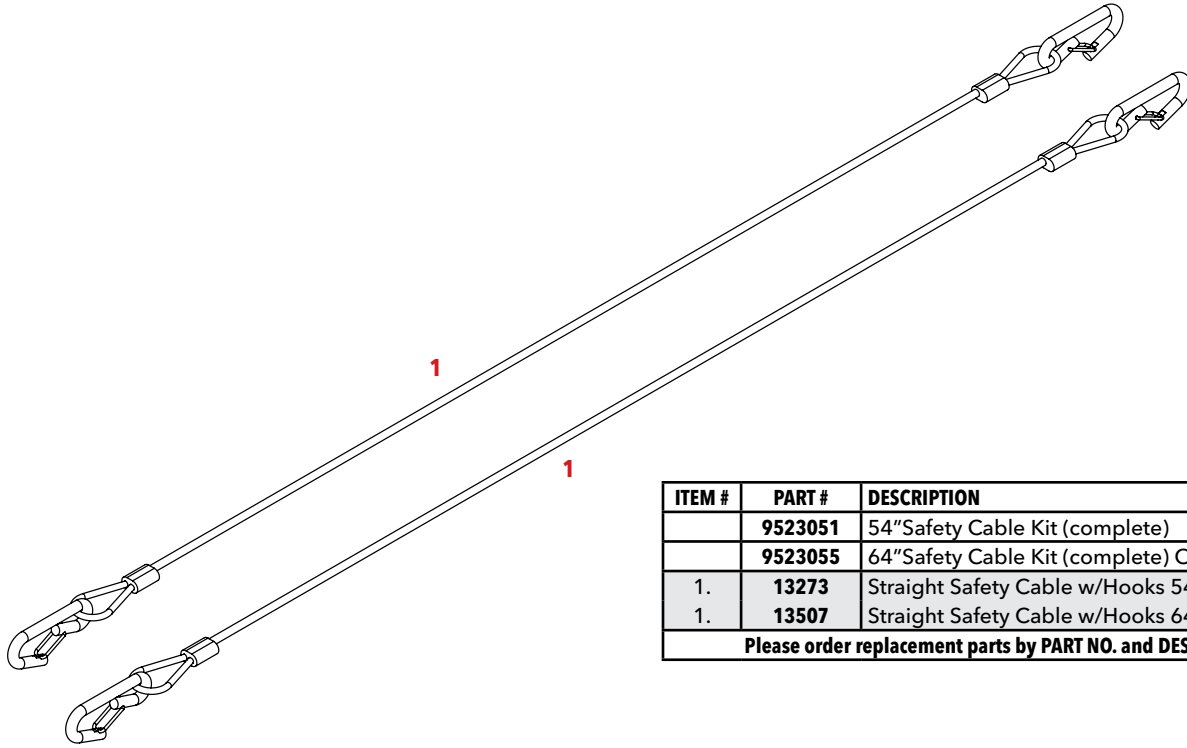

ITEM #	PART #	DESCRIPTION	Qty
	9523051	54" Safety Cable Kit (complete)	
	9523055	64" Safety Cable Kit (complete) Optional	
1.	13273	Straight Safety Cable w/Hooks 54"	2
1.	13507	Straight Safety Cable w/Hooks 64"	2

Please order replacement parts by PART NO. and DESCRIPTION.

Safety Cable Extensions

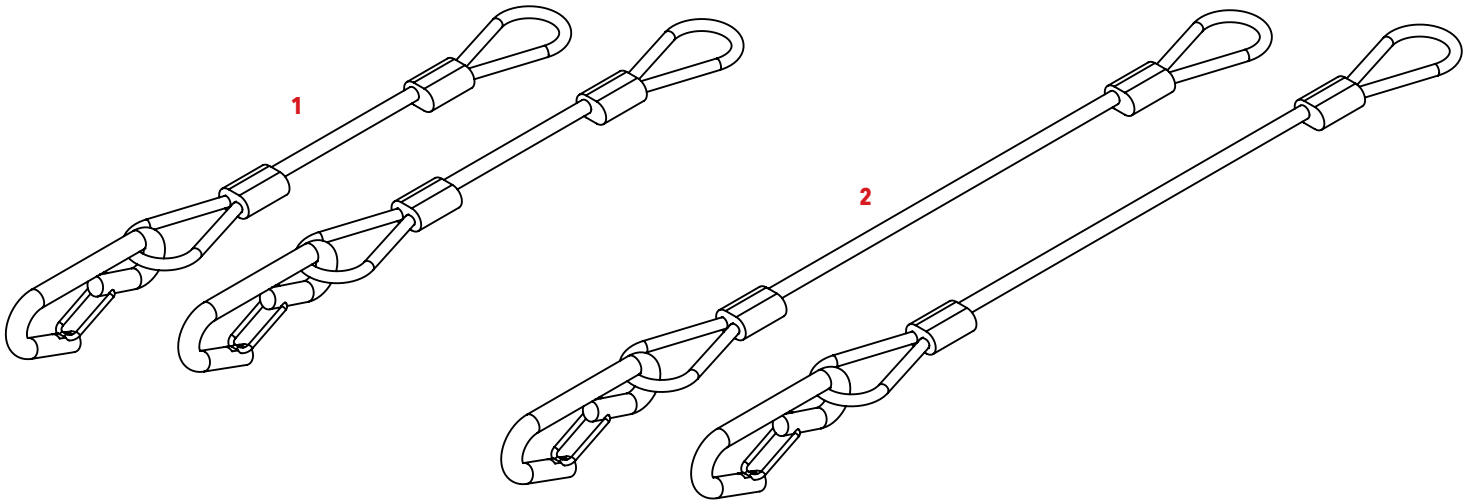

ITEM #	PART #	DESCRIPTION	Qty
	9523064	12" Safety Cable Extension Kit	
	9523065	18" Safety Cable Extension Kit	
1.	13779	Safety Cable Extension 12"	2
2.	13780	Safety Cable Extension 18"	2

Please order replacement parts by PART NO. and DESCRIPTION.

Tow Bar Options

4" or 6" Drop/Lift Receiver Hitch

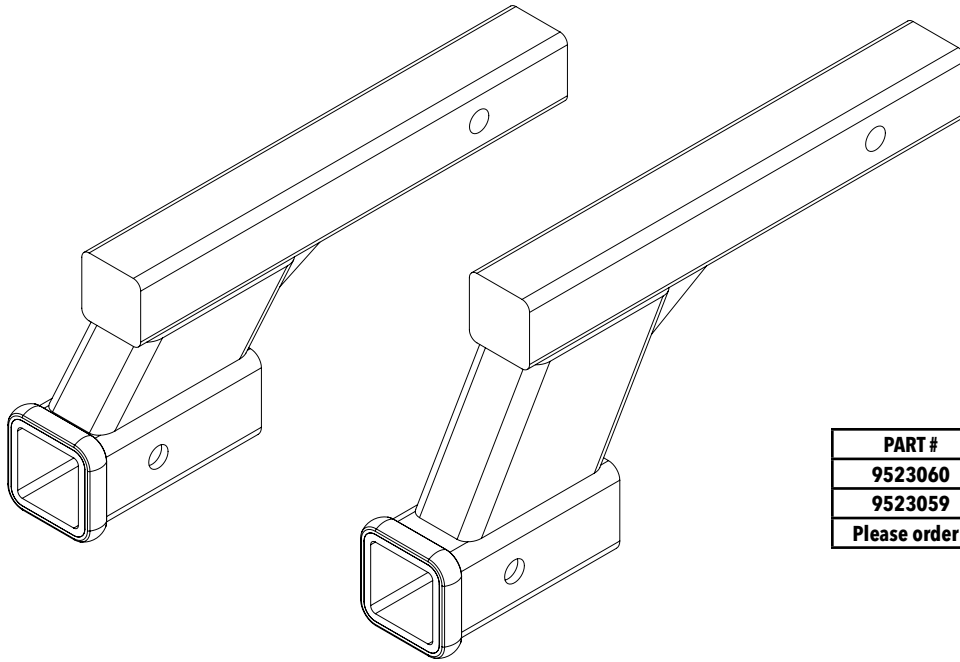

PARTS LIST

PART #	DESCRIPTION
9523060	6" Drop/Lift Receiver Hitch (complete)
9523059	4" Drop/Lift Receiver Hitch (complete)
Please order replacement parts by PART NO. and DESCRIPTION.	

Auxiliary Lighting Cable

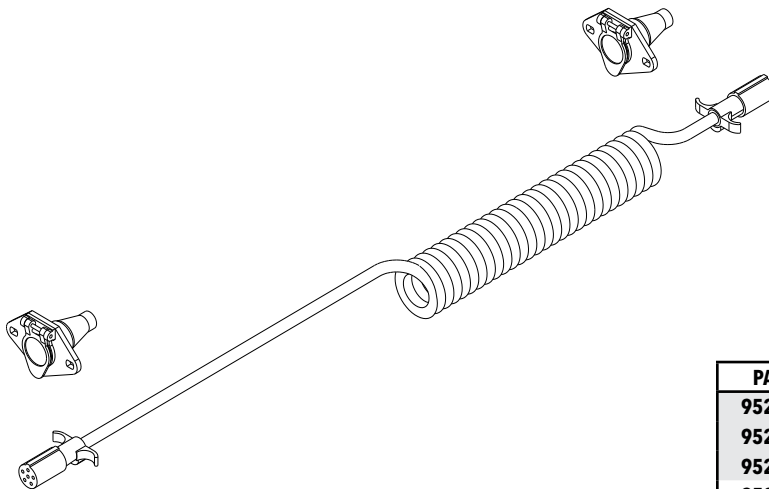

NOTE: To be used with optional Light Bar, the ends will have to be cut off light bar harness. This end will then need to be wired to the receptacle of the auxiliary lighting kit.

AVAILABLE WIRING KITS

PART #	DESCRIPTION
9523004	4-Way Auxiliary Coiled Lighting Cable w/recpt.
9523006	6-Way Auxiliary Coiled Lighting Cable w/recpt.
9523009	9523004 & Towed Vehicle Tail Light Wiring/Diode Kit
9523010	Towed Vehicle Tail Light Wiring/Diode Kit Only
9523011	9523006 & Towed Vehicle Tail Light Wiring/Diode Kit
9523054	7 to 6-Way Auxiliary Coiled Lighting Cable w/recpt.
Please order replacement parts by PART NO. and DESCRIPTION.	

NOTE: For replacement parts, call original manufacturer or DEMCO at 1-800-543-3626

Tow Bar to Base Plate Locking Pins



PARTS LIST

ITEM #	PART #	DESCRIPTION
	9523067	Tow-Bar to Base Plate Locking Pin Set
1.	14054	Tow-Bar to Base Plate Single Locking Pin Assembly
Please order replacement parts by PART NO. and DESCRIPTION.		

3-Piece Locking Pins



PARTS LIST

ITEM #	PART #	DESCRIPTION
	9523068	3-Piece Locking Pin Set
1.	14054	Tow-Bar to Base Plate Single Locking Pin Assembly
2.	14047	Tow-Bar to Motor Home receiver Locking Pin
Please order replacement parts by PART NO. and DESCRIPTION.		

Tow Bar Options

Light Bar

COLOR CODE FOR WIRING HARNESS

WHITE	Ground
BROWN	Tail Lights, License Plate Lights, Light Cluster Bar & Clearance Lights
YELLOW	Left Turn and Stop
GREEN	Right Turn and Stop

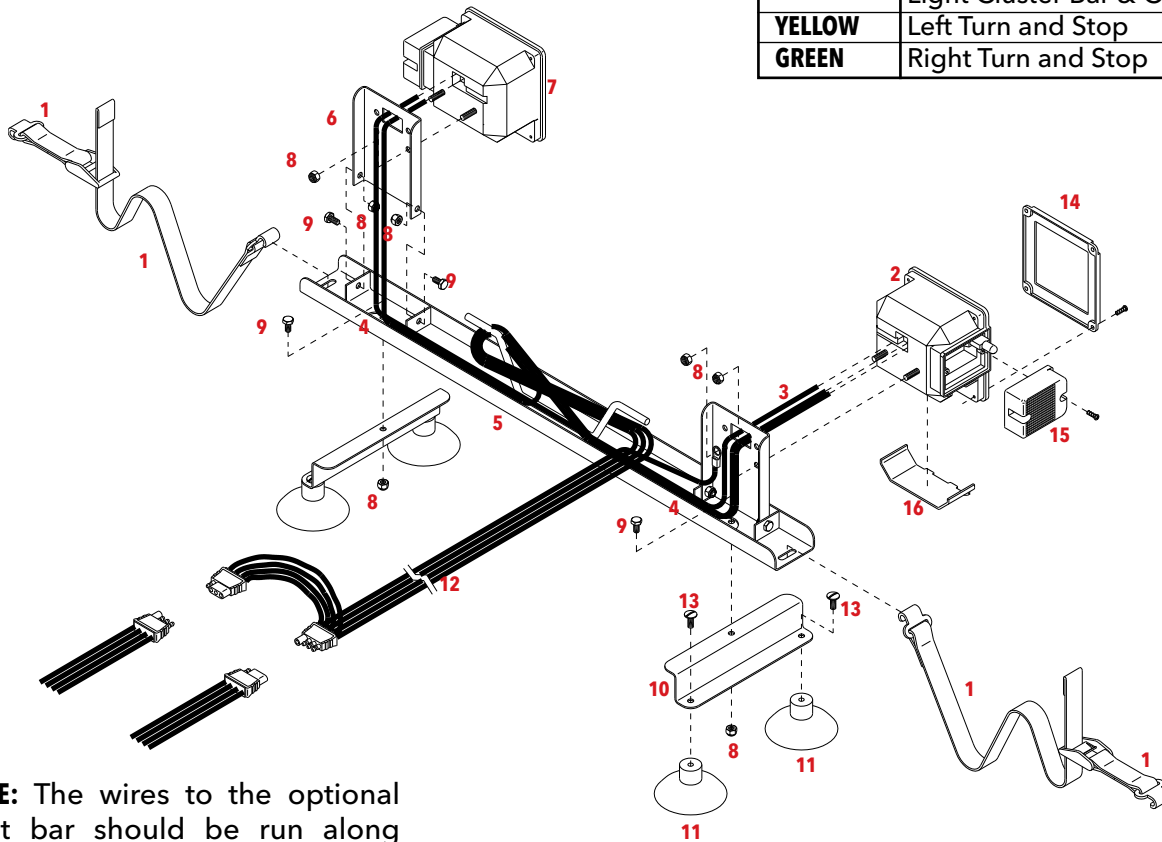

NOTE: The wires to the optional light bar should be run along the car and fastened so as not to damage the finish of the towed vehicle.

PARTS LIST

ITEM #	PART #	DESCRIPTION	Qty
	KKLB	Commander II Light Bar (complete)	
1.	01772	Nylon Security Strap with hooks & tightener	2
2.	01857	Left Tail/ Brake and Signal Light w/Lenses	1
3.	01773	Brown Jumper Wire	1
4.	01886	Wire Holder (metal)	4
5.	02385	Light Bar Framework	1
6.	02386	Adjustable Light Bracket	2
7.	01856	Right Tail/ Brake and Signal Light w/Lenses	1
8.	02772	1/4"-20UNC Nylon Insert Locknut	10
9.	00092	1/4"-20UNC x 1/2" Hex Head Bolt	6
10.	01777	Light Bar "Z" Bracket	2
11.	01778	3" Suction Cup w/Bolt (#13)	4
12.	02198	Light Bar Wiring Harness (new style)	1
13.	00068	1/4"-20UNC x 3/4" Hex Head Bolt	4
14.	01911	Large Red Lens	-
15.	01912	Small Red Lens	-
16.	01890	Clear Lens	-

Please order replacement parts by PART NO. and DESCRIPTION.

TESTING LIGHTS BEFORE USE

1. With headlights in "ON" position, the tail lights and the clearance lights should be lighted.
2. Start engine and have someone depress brake pedal. Brake lights of the light bar and towing vehicle should come "on" and "off" simultaneously with each application.
3. Turn left turn signal on. Left turn light of light bar and towing vehicle should flash simultaneously. Should the turn signal lights of the light bar function opposite to those of the towing vehicle, it is probable that the **YELLOW** and **GREEN** wires have been reversed. Check the plug connections to make sure wire colors are not crossed at any point. If plug connection is incorrect, correct problem by reversing yellow and green wire connection on the towing vehicle.

DEMCO

4010 320th St., Boyden, IA. 51234

Phone: (712) 725-2311

Fax: (712) 725-2380

Toll Free: 1-800-54DEMCO (1-800-543-3626)

**Demco warranty policies, operator manuals, and product registration
can be found online:**

www.demco-products.com

