

# **OWNER'S MANUAL**

## **ATTENTION INSTALLER**

This manual **MUST** accompany the owner of this Recon 2-5/16" Ball Mount

# **DEMCO**

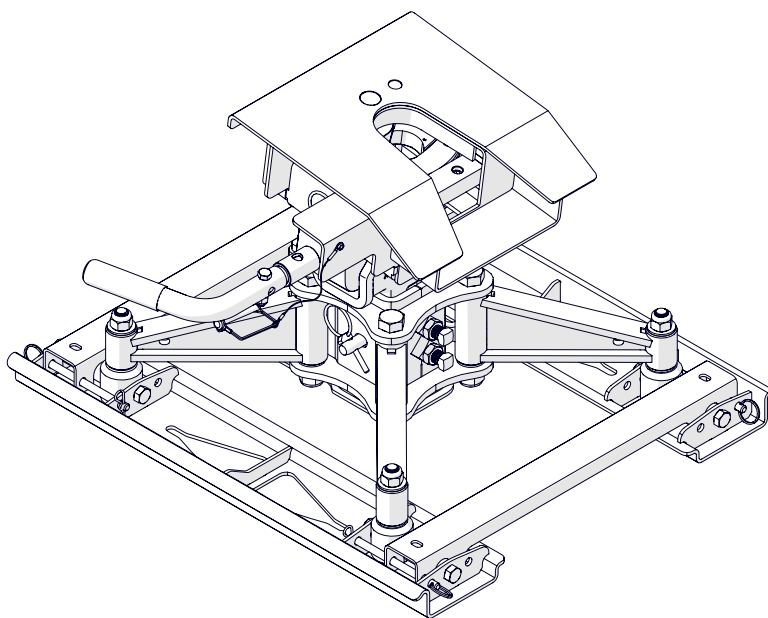

**IMPORTANT  
WARRANTY REGISTRATION HERE:**



**SERIAL NUMBER**

# Introduction

Thank you for purchasing a Demco Recon hitch. We feel you have made a wise choice and hope you are completely satisfied with your new piece of equipment.

## WARRANTY POLICY, OPERATOR MANUALS & REGISTRATION

Go online to [www.demco-products.com](http://www.demco-products.com) to review Demco warranty policies, operator manuals and register your Demco product.

### GENERAL INFORMATION

1. Unless otherwise specified, high-strength (grade 5) (3 radial-line head markings) hex head bolts are used throughout assembly of this piece of equipment.
2. Whenever the terms "**LEFT**" and "**RIGHT**" are used in this manual it means from a position behind the vehicle and facing forward.
3. When placing a parts order, refer to this manual for proper part numbers and place order by **PART NO. and DESCRIPTION.**

**Bolt Torque for Standard bolts \***

"A"	GRADE 2		GRADE 5		GRADE 8	
	lb-ft	(N.m)	lb-ft	(N.m)	lb-ft	(N.m)
1/4"	6	(8)	9	(12)	12	(16)
5/16"	10	(13)	18	(25)	25	(35)
3/8"	20	(27)	30	(40)	45	(60)
7/16"	30	(40)	50	(70)	80	(110)
1/2"	45	(60)	75	(100)	115	(155)
9/16"	70	(95)	115	(155)	165	(220)
5/8"	95	(130)	150	(200)	225	(300)
3/4"	165	(225)	290	(390)	400	(540)
7/8"	170	(230)	420	(570)	650	(880)
1"	225	(300)	630	(850)	970	(1310)

**Bolt Torque for Metric bolts \***

"A"	CLASS 8.8		CLASS 9.8		CLASS 10.9	
	lb-ft	(N.m)	lb-ft	(N.m)	lb-ft	(N.m)
6	9	(13)	10	(14)	13	(17)
7	15	(21)	18	(24)	21	(29)
8	23	(31)	25	(34)	31	(42)
10	45	(61)	50	(68)	61	(83)
12	78	(106)	88	(118)	106	(144)
14	125	(169)	140	(189)	170	(230)
16	194	(263)	216	(293)	263	(357)
18	268	(363)	--	--	364	(493)
20	378	(513)	--	--	515	(689)
22	516	(699)	--	--	702	(952)
24	654	(886)	--	--	890	(1206)



### **WARNING**

#### **Failure to follow these instructions may result in death or serious injury!**

- Trailer and its contents together must not exceed truck, hitch and/or trailer tow ratings.
- Towing vehicle must have a manufacturer's rated towing capacity equal to or greater than the gross trailer weight (dry weight of the trailer plus payload of the trailer).
- Gross weight of trailer must not exceed weight rating of hitch assembly.
- King pin weight must not exceed 4,000 pounds. If in doubt have king pin weight measured by qualified facility.
- Do NOT Use a Wedge. Do NOT prevent the kingpin from rotating within jaws of the Recon Goose Ball Coupler with a wedge or other device.
- Do NOT place hitch on top of a plastic bedliner. Hitch must have direct contact with the truck bed.

1. Demco 5th wheel hitches are designed for use with recreational fifth wheel trailers only.
2. Use only a SAE 2-inch king pin with your Demco 5th Wheel Hitch.
3. Approximately 15%-25% of trailer weight should be on hitch (Pin Weight).
4. Trucks come in many different configurations. Demco hitches are designed for use in light trucks such as the Ford F-Series, the Chevy Silverado and the Dodge Ram. Demco recommends the use of long bed (8ft) light trucks for the best combination in truck - trailer turning clearance.

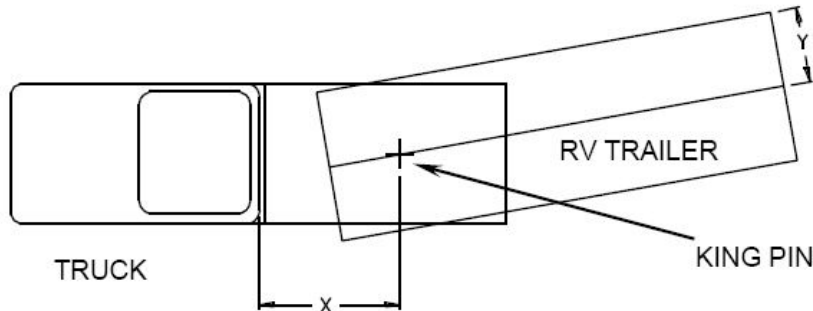

Rule of thumb: The distance from the back of the truck cab to the center of the rear truck axle ("X"), should be approximately 4 inches greater than one-half the trailer width ("Y")

5. If a short bed pickup (less than 8 ft. but longer than 6 ft.) is to be used for towing, Demco recommends the trailer be equipped with an extended pin box to help gain additional truck - trailer turning clearance (See trailer manufacturer for options). It also may be helpful to add a Demco 5th Wheel Ultra Slide for increased turning clearance for low speed, non- highway maneuvering.
6. The height of the hitch and the pin box should be adjusted so the trailer is approximately level as it is towed. Allow approximately 6 inches clearance between the top of the pickup walls and the underside of the front of the trailer for pitch and roll of the trailer. Allow more clearance between pickup walls and trailer for off road use.

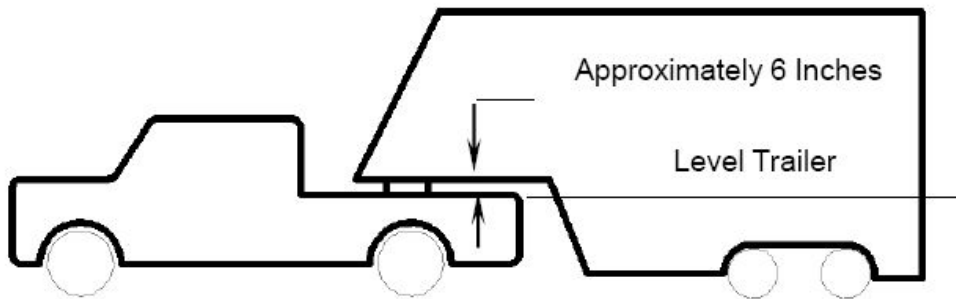

# 5th Wheel Double Pivot Head Assembly

The dampener stops the hitch head from flopping back and forth in the truck when the trailer is not hooked up. The urethane compresses under load so it does not restrict the fore and aft movement when coupled.

Before attaching the hitch head to the saddle assembly the urethane dampener will need to be installed. It is included in the bag with the bolt and nut for the hitch handle. Simply press into hole that is punched into the bottom side of the hitch as shown in **Figure A**.

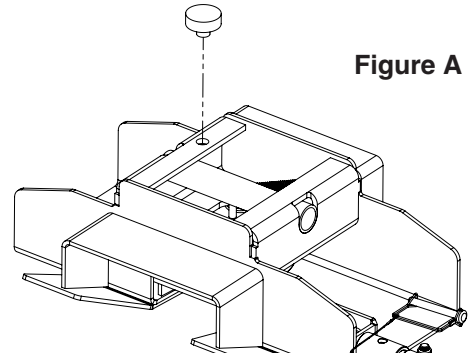
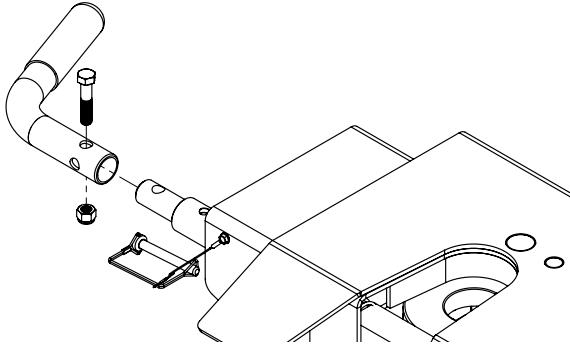

Figure A

**Note (Read carefully before installing):** Handle can be positioned toward the front or the back if it is found to interfere with the trailer in any way. Verify this before traveling.

1. Slide yellow gripped handle over locking bar, the handle may point forward, upward or backward. **\*\*DO NOT** have pointing upward if it is found to interfere with the trailer in any way during turning.
2. Fasten with 3/8" x 1 3/4" bolt and lock nut provided.



## **WARNING**

**DO NOT** install hitch handle in a position that the pin box could come in contact with or interfere with the latch of the hitch handle when turning! If the pin box contacts the hitch handle or its latch when turning, the trailer may become unhitched.

## Procedures to Close Locking Bar

Pull on handle with slight pressure while moving the secondary jaw to the right until the primary jaw is released. Slowly allow the handle to retract into the 5th wheel head. Caution: Do not put hands/fingers into the lock jaw area.

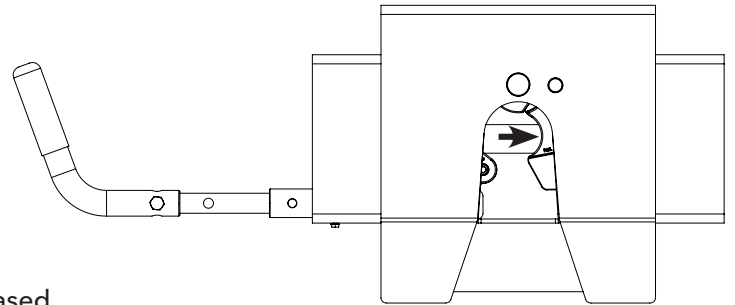

## 5th Wheel Pivot Head Maintenance

Each of our 5th wheel hitches has been tested and pre-greased at our production facility to help ensure easy operation of your new product.

As it is a new piece of equipment with some moving parts, a period of wearing in may be necessary to facilitate smoother operation for your new fifth wheel hitch. The most important thing to remember is to keep all moving parts well greased and lubricated. Your doing this will help to ensure longer product life.

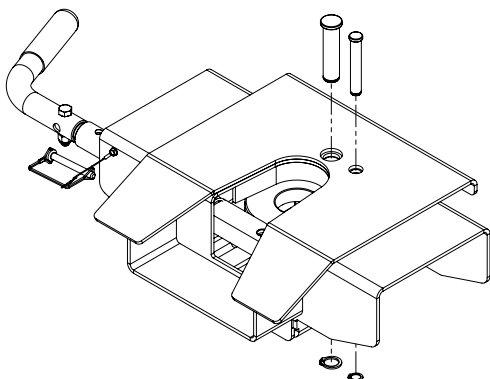

Squirt WD40 or other oil into locking bar tube, open and close locking bar several times and wipe bar clean.

Apply a light coat of grease between arrows.

Jaw pins can be removed and greased by removing or unhooking jaw spring and both snap rings. Tap the pin up from bottom. Clean pins and inspect for wear, apply light coat of grease and reinstall pins, snap rings and spring.

## Coupling Procedure

1. Place wheel chock on each side of trailer wheels.
2. Adjust trailer jacks until trailer is a height for hook up. King pin plate should contact hitch approximately 1/2" below level.

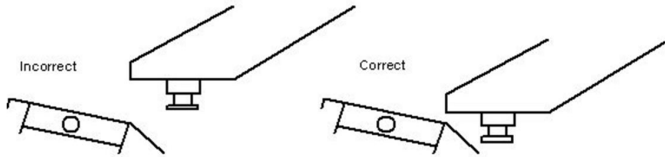

3. Lower tailgate of truck.
4. If hitch is in locked position, remove safety pin and pull handle out to the "Ready to Couple" position.
5. Line truck so that the hitch will accept king pin. Back truck up slowly towards trailer until king pin engages. Hitch will lock when king pin is fully engaged.
6. With the trailer coupled, visually check to see if hitch is completely locked by looking at the handle position, as well as visually checking to ensure that the jaw bar has traveled completely across the front of the king pin.
7. Place safety pin thru the tab and the hole in the handle. This will prevent handle from opening.
8. Connect power cable and breakaway switch cable between truck and trailer.
9. Close and latch tailgate.
10. Apply trailer brakes and try to pull forward slowly to double check that hitch is locked. Trailer should prevent truck from moving.
11. Completely raise trailer jacks. Check for proper clearance between truck box and trailer.
12. Pick up and store wheel chocks. You are now ready to travel.

## Uncoupling Procedure

1. Place wheel chocks on both sides of trailer wheels.
2. Lower trailer jacks to ground and extend until load is level with truck suspension. If on soft ground, place support under jack feet to prevent trailer from settling.
3. Lower tailgate on truck.
4. Disconnect power cable and break away switch.
5. Remove lock pin and pull handle out. If handle will not stay out, install safety pin in second handle hole just outside of frame handle bushing.
6. Drive truck slowly away from trailer.

## Very Important Maintenance Instructions

1. Inspect all fasteners for tightness at least every 2,000 miles of operation.
2. Inspect jaw and jaw bar for freedom of movement and proper operation before each use. Replace all damaged or worn parts.
3. Keep all moving parts of hitch well lubricated.
4. It is recommended to use grease or a 3/16" maximum Teflon disc to help prevent wear on top plate surface.

## Very Important Warnings

1. Know your vehicle and trailer GVWR and CVWR. DO NOT exceed capacity of hitch.
2. Hitch is for use with only a standard 2" king pin.

Safety pin MUST be fastened securely before moving vehicle and/or traveling

### Ready to Couple

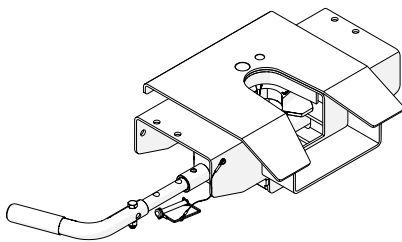

Remove safety lock pin if installed and pull handle until jaw locks open.

### Coupled and Locked

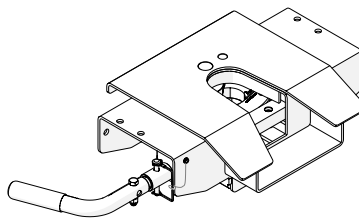

With handle in "Ready to Couple" position, back-up tow vehicle to couple trailer and hitch. Insert safety pin thru tab and hole in handle. NOTE: Ensure safety lock pin is inserted properly. Apply trailer brakes before jacks are raised and wheel chocks are removed.

### Uncoupled

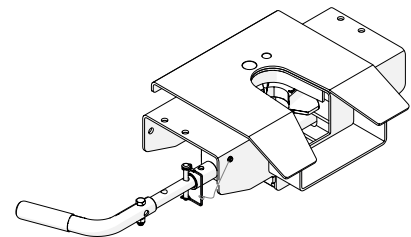

To uncouple, remove safety pin, pull handle straight out until the jaw locks open. If jaw will not stay open, install safety pin in second handle hole just outside of frame handle bushing.

**VISUALLY INSPECT JAW LOCKING MECHANISM BEFORE TRAVELING**

## Recon Installation Instructions

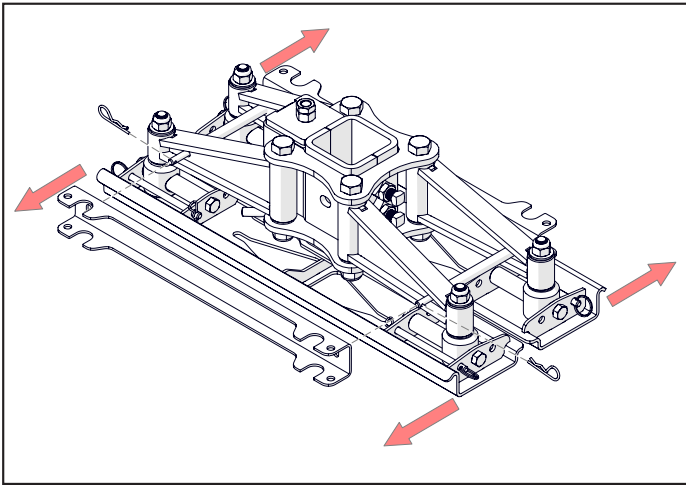

1. Unfold the Recon by removing the hair pins from the storage pins. remove the support braces from the pivot arms. Pull the arms outwards on each side to allow room for the hitch ball .

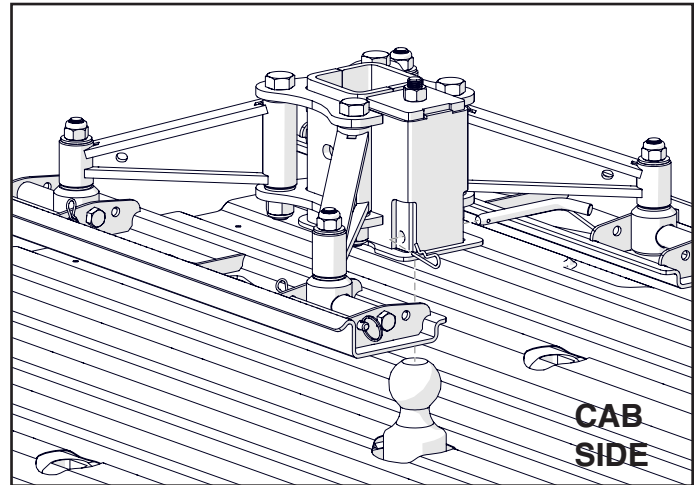

2. Put the Recon hitch over the gooseball and into the Recon's ball socket. Slide coupler pin into coupler hole, making sure pin goes under gooseneck ball. Top coupler nut may need to be loosened for pin to go under the ball.

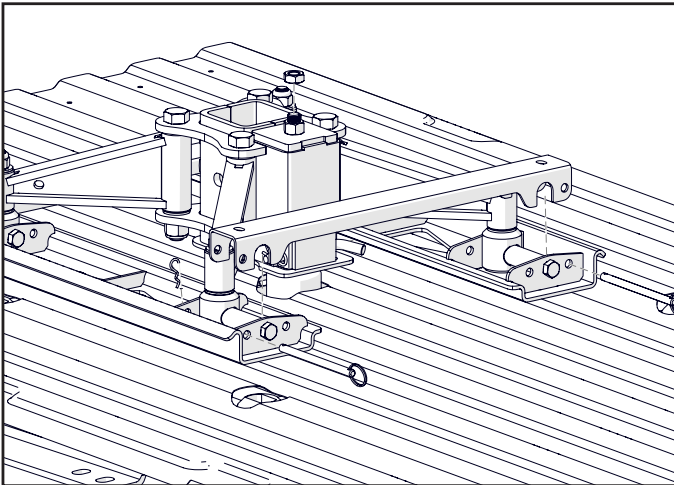

3. When coupler pin is installed, make sure the pivot arms are fully out and install the support bars over the slide rods and pin them to the base pads. Tighten top coupler nut to 30 ft/lbs. Install jam nut and tighten.

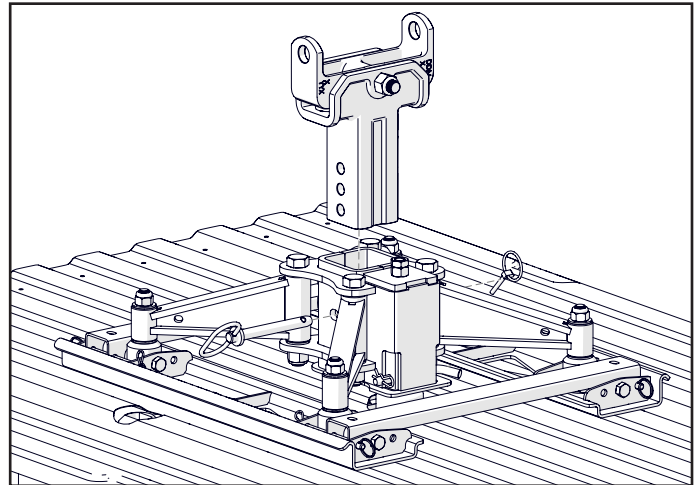

4. The correct height for the hitch is such that there is approximately 6" of clearance between the top of the truck box and the bottom of the trailer overhang. The Demco Recon hitch has 2-1/2" of adjustment up or down in 1-1/4" increments. Once the proper height has been determined, slide the center post to the right position and pin with cross pin and tighten setscrews and jam nuts of base. It is best to use a 3/4" twelve point socket to tighten the set screws to 85 ft/lbs and a 15/16" deep well socket for the jam nuts.

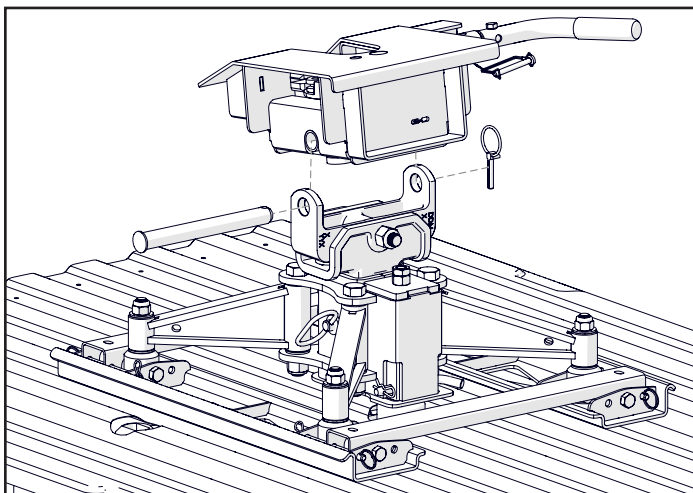

5. Install 5th wheel head with the 1" pin.

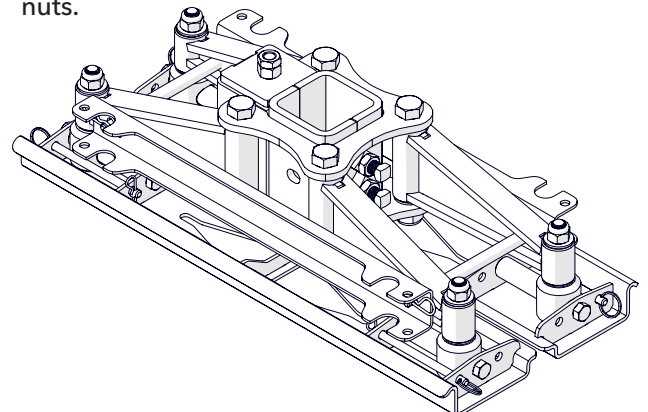

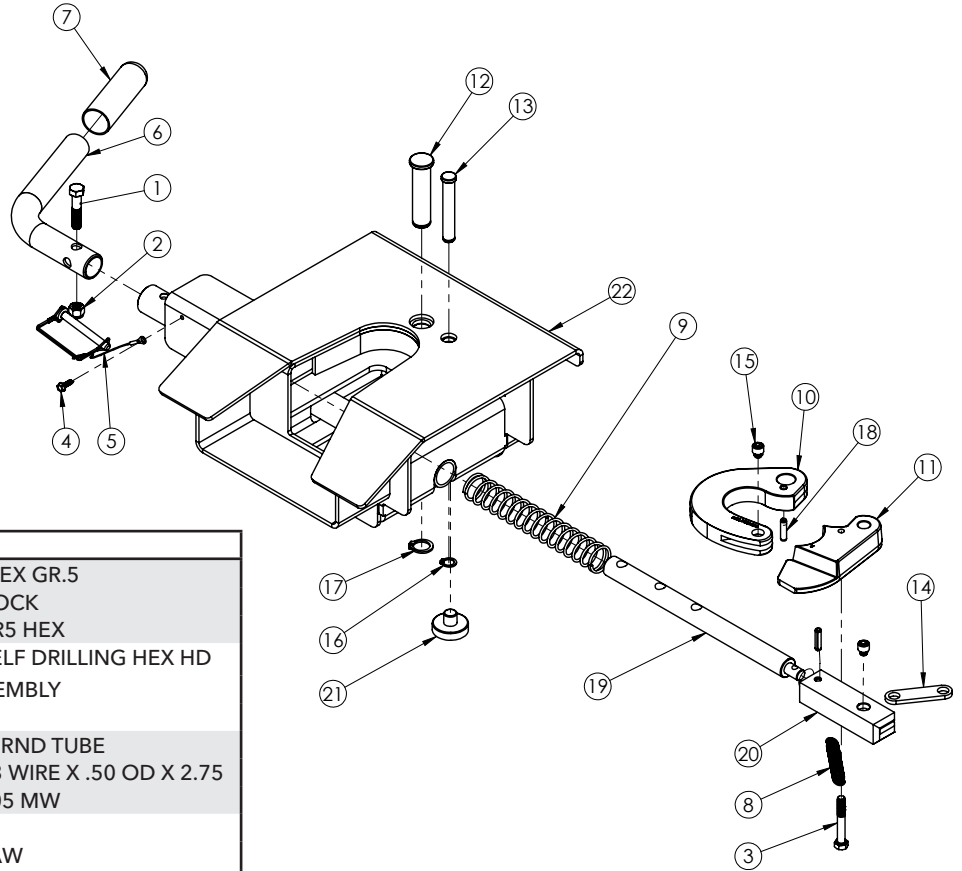

**6169 Parts Breakdown**

ITEM	PART #	QTY	DESCRIPTION
1	00908	1	BOLT, .375 NC X 1.75 HEX GR.5
2	02592	1	NUT, .375NC NYLON LOCK
3	03547	1	BOLT .313NC X 2.25 GR5 HEX
4	03787	1	SCREW #10NC X .50 SELF DRILLING HEX HD
5	05337	1	SAFETY LOCK PIN ASSEMBLY
6	14214-72	1	HITCH HANDLE
7	14216	1	YELLOW GRIP F/ 1.125 RND TUBE
8	14315	1	SPRING, TENSION, .063 WIRE X .50 OD X 2.75
9	14385	1	SPRING COMPRESS .105 MW
10	14594-95	1	JAW HOOK
11	14595-95	1	SECONDARY LATCH JAW
12	14735-95	1	MAIN JAW PIN
13	14736-95	1	SECONDARY JAW PIN
14	14737-95	1	BAR/JAW LINK
15	14747	2	SCREW .313NC X .25 SOCKET HD CAP
16	14749	1	SNAP RING EXT FOR .50 SHAFT
17	14750	1	SNAP RING EXT F/ .75SHAFT
18	14865	2	ROLL PIN, .25 X 1.00
19	14867-95	1	LEVER ARM BAR
20	14869-95	1	LOCK BAR
21	15769	1	URETHANE PIVOT BUMPER 3/8" THICK
22	15801-72	1	5th WHEEL DOUBLE PIVOT HEAD

Please order replacement parts by **PART NO.** and **DESCRIPTION**

**Recon Base Parts Breakdown**

**6526 Base Parts Breakdown**

ITEM	PART #	Qty	DESCRIPTION
1	00182	4	HAIR PIN, .120 WIRE X 2.375
2	00489	2	NUT .625NC JAM RIGHT HAND
3	02534	8	WASHER, MACHINE, .75 X 14GA NR
4	02961	4	NUT, .75NC LOCK NYLON INSERT
5	09946	2	SET SCREW .625NC X 2.00 SQ HD
6	13296-95	4	BOLT, .75 NC x 6.00 w/ 4.75 SHANK
7	18571-72	1	BASE CENTER
8	18694-78	4	RECON PIVOT ARM
9	18783-95	2	STORAGE PIN/HANDLE

Please order replacement parts by **PART NO.** and **DESCRIPTION**

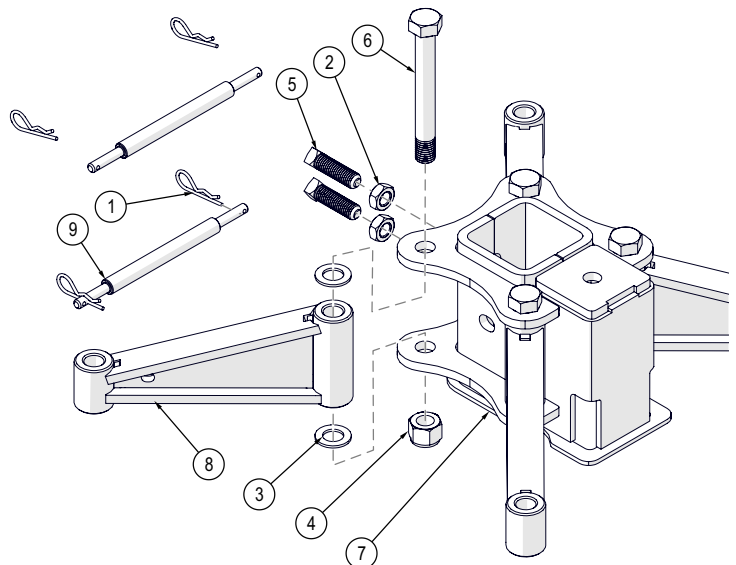

# Recon Base Parts Breakdown

## 6526 Base Parts Breakdown

ITEM #	PART #	DESCRIPTION	Qty
1	02534	WASHER, MACHINE, .75 X 14GA NR	8
2	02587	NUT, .625 NC NYLON LOCK	4
3	04795	BOLT .50NC X 1.00 GR5 HEX	8
4	07225	SPLIT RING	4
5	14350	HAIR PIN, .093 WIRE X 1.63 OL	4
6	18572-72	BASE PAD	2
7	18573	SLIDE ROD	4
8	18574-72	SUPPORT BRACE	2
9	18572-95	PIVOT SLIDE	4
10	18812-95	RETAINING PIN	4

Please order replacement parts by PART NO. and DESCRIPTION

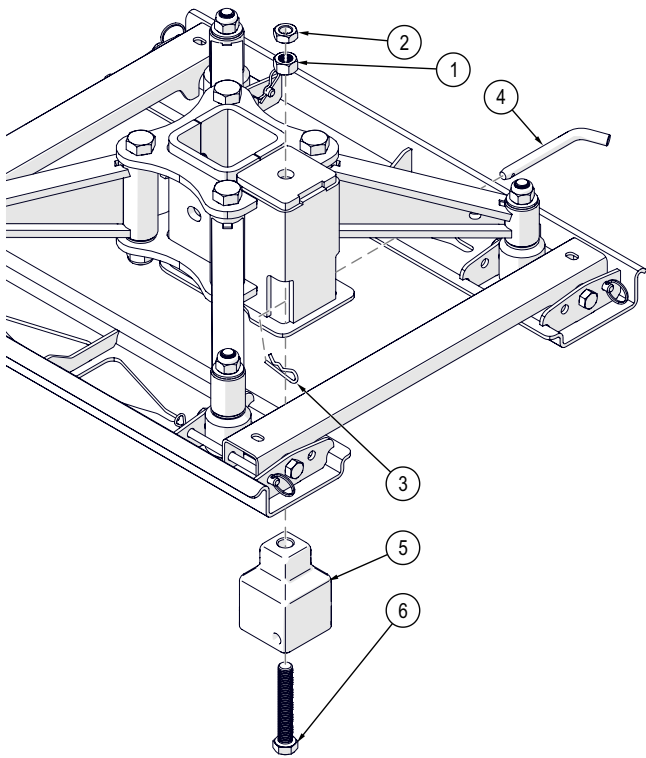
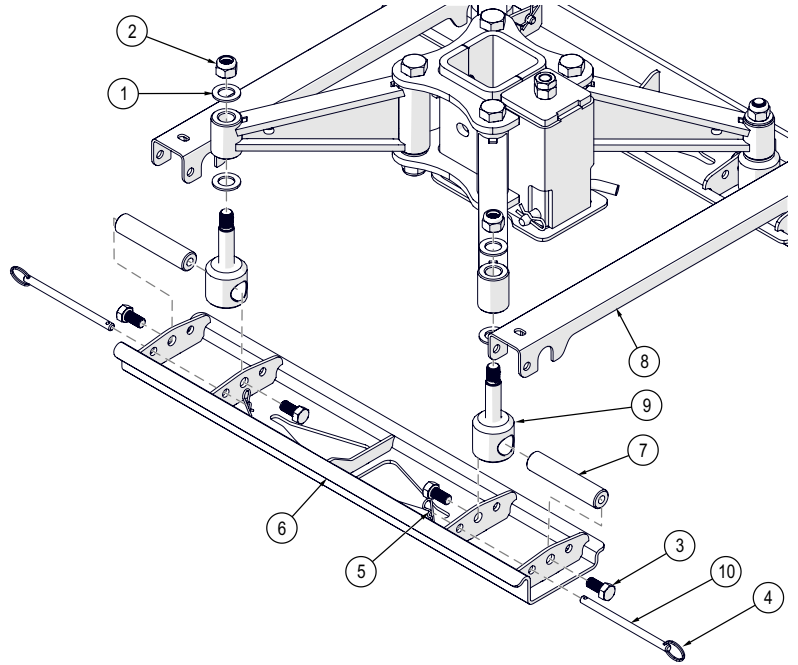

## 6526 Base Parts Breakdown

ITEM #	PART #	DESCRIPTION	Qty
1	00291	.625NC HEX NUT	1
2	00489	NUT .625NC JAM RIGHT HAND	1
3	00182	HAIR PIN	1
4	15930	PIN .50 X 4.00 BENT HANDLE W/HAIR PIN	1
5	17129	2.313 COUPLER, RECON	1
6	17333	BOLT .625NC X 4.00 FULL THREAD GR5	1

Please order replacement parts by PART NO. and DESCRIPTION

## 6526 Base Parts Breakdown

ITEM #	PART #	DESCRIPTION	Qty
1	02397	LYNCH PIN	1
2	02961	NUT, .75NC LOCK NYLON INSERT	1
3	11099	BOLT, .75 NC X 5.00 HEX HEAD GR. 8	1
4	11337	HINGE BUSHING	1
5	11593	HITCH PIN, .625 W/ HAIR PIN	1
6	14221	LYNCH PIN, .313	1
7	14222	AS PIVOT PIN 1" X 9.38	1
8	15769	URETHANE PIVOT BUMPER 3/8" THICK	2
9	15773	UPRIGHT CASTING	1
10	15778	5th WHEEL HEAD YOKE	1

Please order replacement parts by PART NO. and DESCRIPTION

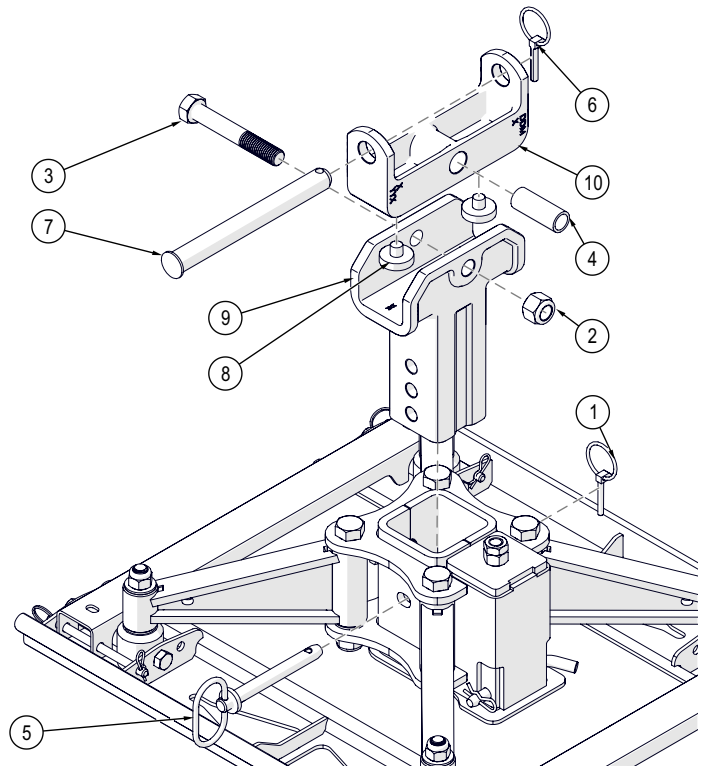

4010 320th St., Boyden, IA, 51234  
 Phone: (712) 725-2311  
 Fax: (712) 725-2380  
 Toll Free: 1-800-54DEMCO (1-800-543-3626)

Demco warranty policies, operator manuals, and product registration  
 can be found online:  
[www.demco-products.com](http://www.demco-products.com)