

INSTALLATION INSTRUCTION AND SERVICE MANUAL

Actuator/Trailer Dealer - Please provide these instructions to the consumer.
Consumer - Read and follow these instructions. Keep them with the trailer for future reference.

TITAN MODEL 60

SURG-O-MATIC ACTUATOR FOR TRAILER BRAKES

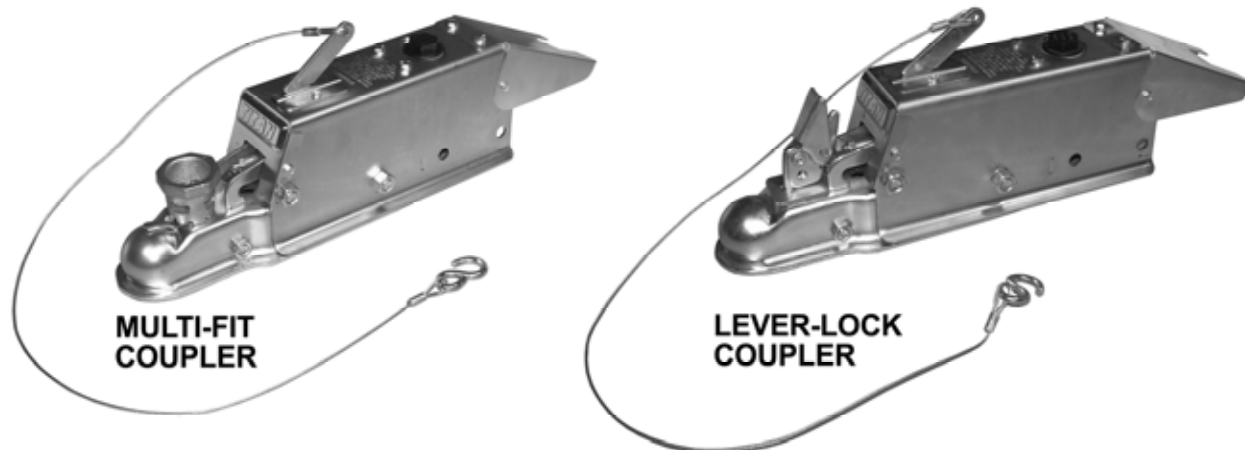

Surge braking is accomplished by replacing a trailer's standard tongue coupler with an actuator and adding hydraulic brake assemblies. The "surge" or "push" of the trailer toward the tow vehicle during deceleration automatically synchronizes these trailer brakes with the tow vehicle brakes. As the trailer pushes against the vehicle, the actuator telescopes together and applies force to its master cylinder, supplying hydraulic pressure to the trailer's brakes.

Surge actuators of this type provide a service life of approximately five years with proper installation, usage, and maintenance. However, a well cared-for actuator can often exceed this estimate. To get the most benefit from your TITAN surge actuator, follow the instructions given in this manual and use common sense in caring for the TITAN MODEL 60 actuator and your entire trailer brake system.

RATED CAPACITY AND USAGE

⚠ WARNING ⚠
DO NOT exceed these ratings

6,000 POUNDS MAXIMUM GROSS LOAD (weight of trailer fully loaded with all cargo and equipment). To find your trailer's Gross Load, use a commercial vehicle scale at a truck weigh station, grain elevator, etc.

600 POUNDS MAXIMUM TONGUE LOAD (weight applied downwards by the fully loaded trailer's coupler onto the tow vehicle's hitch). Measure your trailer's Tongue Load with the tongue in the horizontal towing position, using either a commercial scale or a bathroom scale if the load is small enough. Upwards tongue loads are not permissible.

The **MODEL 60** actuator is intended for light occasional use on recreational, marine, and baggage trailers, which are towed by passenger cars or pickups. The actual in-service rating is limited to that of the ball and hitch being used or the trailer manufacturer's G.V.W.R. shown on the certification label, whichever is lower. The actuator will provide enough fluid displacement to supply up to four TITAN free-backing or uni-servo drum style trailer brakes.

 **TITAN**
A Titan Company
2345 East Market Street
Des Moines, IA 50317
800-USA-BEAR or 800-872-2327
FAX 515-265-9301

INSTALLATION

⚠ WARNING ⚠

DO NOT submerge the actuator. Internal corrosion may result and cause brake failure. Salt water, granular fertilizers, and other corrosive materials are destructive to metal. To minimize the damaging effect of corrosion on a braking system used under corrosive conditions, we recommend that the actuator be externally flushed after use with a high pressure water hose. Be sure to lubricate all moving parts after the unit has dried. Whenever the unit will be out of service for an extended period of time, or after hard use, remove the brake drums and clean inside the brakes. Pack wheel bearings with grease before the drum is installed. Failure to properly and adequately grease and maintain the actuator could weaken it and/or cause it to fail and result in serious injury and/or property damage.

1. The MODEL 60 Actuator is completely assembled and ready to bolt into place onto straight three inch wide trailer tongues. **WELDING IS NOT RECOMMENDED** since it will make repair or replacement difficult, destroy the plated or painted surface finish, and could potentially cause internal damage resulting in decreased brake performance. If the actuator must be painted for aesthetic reasons, TITAN recommends painting **ONLY** the outer case, and disassembling the unit prior to painting. Application of heavy coats of paint may interfere with component operation. Confirm the coupler and break-away mechanisms work properly before operation. Store actuators indoors and in their original shipping carton until the time of installation.
2. Bolt the actuator to the tongue using 1/2 inch by 4 inch grade 5 bolts, nuts, and lock washers. The two holes match standard coupler mounting holes on three inch wide trailer tongues, as shown in Figure 1. light weight tongues require spacer tubes inside for reinforcement such as a 3/4 inch outside diameter by eleven gauge piece of tubing. Using a torque wrench, tighten bolts to eighty (80) foot-pounds torque.
3. Install the hydraulic brakes and brake lines on the trailer as described in the installation manual supplied with the brakes. **DO NOT** crush or kink the tubing as you mount the actuator. TITAN recommends 3/16 inch brazed double wall tubing per S.A.E. J527 for use with all our actuator and brake products. Use forty-five degree (45°) double-flare tube ends per S.A.E. J533. **DO NOT** remove or modify the orifice connector <17> at the rear of your actuator's master cylinder. It connects directly to the brake tubing and ensures proper fluid flow characteristics.
4. After installation of the actuator, brake, and brake lines as described above, proceed immediately to the "BRAKE FLUID FILLING AND BLEEDING" instructions.

FIG. 1 - TRAILER AND TRAILER TONGUE BOLT PATTERN (side view shown)

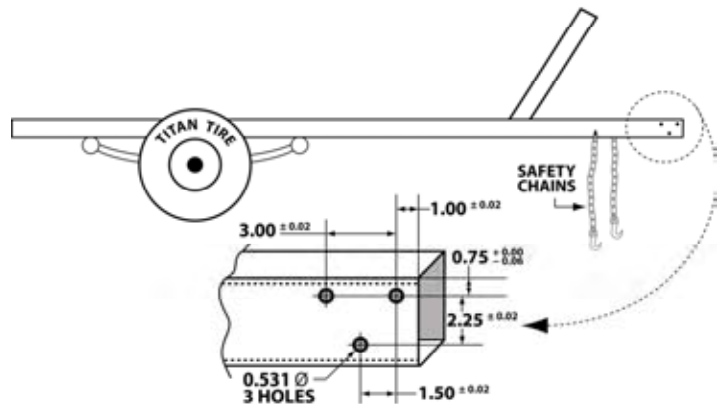

⚠ WARNING ⚠

Failure to complete the "BRAKE FLUID FILLING AND BLEEDING" procedures promptly after installation may result in internal master cylinder corrosion and cause brake failure.

INSTALLATION (cont.)

⚠ WARNING ⚠

Use only fresh brake fluid from a sealed container. DO NOT reuse fluid. After filling and bleeding, remember to refill the actuator. Failure to maintain an adequate fluid level may cause brake failure.

3. Fill the system with DOT-3 heavy duty hydraulic fluid using a pressure type brake bleeder. (This type of brake bleeder is available at your local automotive jobber.) Follow manufacturer's directions.

Brake Fluid Filling and Bleeding

- 3a. After completing the "Installation" instructions, remove the master cylinder cap and fill the reservoir to three-quarters full with DOT-3 brake fluid. DO NOT allow brake fluid to contact painted surfaces since it will damage the finish. Wipe up any spills immediately and wash the area with water.
- 3b. If you choose to manually bleed the system, an assistant makes the job easier. Please note the diagram in figure 2 (on the next page). Disconnect the trailer from the tow vehicle and hook the safety chains (NOT the actuator breakaway cable) together to form a loop. The loop should be centered below the actuator's coupler as shown in Figure 2.
- 3c. Place a sturdy board such as a 2 x 4 into the safety chain loop below the coupler. The board should be four feet long or more so it will extend well above the actuator. Position the board to press against the front end of the actuator's coupler and use it to force the coupler case into the actuator's outer housing. This pumps the brake fluid into the trailer braking system. Manually pull the coupler case back to fully extended position and repeat the process.
- 3d. When the air bubbling stops inside the master cylinder, install a bleeder hose on the bleeder screw of the first wheel cylinder to be bled. Start with the rear axle on tandem axle trailers. Submerge the other end of the hose in a glass container of brake fluid so that air bubbles can be observed. Open the bleeder screw one turn before pushing the coupler case in. When the coupler is pushed completely in, the bleeder screw should be closed to prevent air from being pulled back into the system. Air trapped in the brake lines will greatly reduce your braking efficiency. Repeat this process until no more bubbles are released with each stroke. Be sure to close the bleeder screw securely.

⚠ WARNING ⚠

DO NOT use the actuator's break-away lever or cable to bleed the brake system.

- 3e. Repeat the bleeding operation at each wheel cylinder. During the bleeding process, replenish the brake fluid so the level does not fall below half full level in the master cylinder reservoir. When bleeding is complete, fill the reservoir to within 3/8" of the top. Install the filler cap securely.

NOTE: <#> Is the reference number shown in the assembly diagram of the actuator located at the end of this manual.

TESTING TITAN SURGE BRAKE SYSTEMS

⚠ WARNING ⚠

It should be noted that the field-test procedure indicates only if the trailer brake system is functional, but DOES NOT provide information on how efficiently it will operate. Regular inspection, maintenance, and adjustment of all brake system components (including the surge actuator, tubing, hoses, brake clusters, drums or disc brake calipers and rotors and associated hardware/support structure) are still required to ensure maximum brake performance and smooth, even brake operation.

Hydraulic surge actuator systems provide automatic and smooth trailer braking without special application by the tow vehicle driver. While this is extremely convenient it can sometimes be difficult to determine if the surge setup is functioning properly. The following steps provide a quick field-test to confirm that the trailer brake system is operational.

1. Move the trailer to flat, level ground, pulling FORWARD several feet before parking. This forward motion will ensure trailers equipped with free-backing brakes are in their normal operating mode. Disconnect the trailer from the tow vehicle and jack the trailer's tongue until it is horizontal.
2. Hook the trailer's safety chains (NOT the actuator's breakaway cable/chain) together to form a loop, which is centered below the actuator's coupler as shown in Figure 2.
3. Place a sturdy board, such as a 2 inch by 4 inch piece of lumber, into the chain loop below the coupler. The board should be 4 feet or longer so it will extend several feet above the actuator. Keep the end of the board a few inches off the ground, and position it to press against the front end of the actuator's coupler.
4. Stand in front of the trailer and face the rear. Apply force to the top end of the board to use it as a lever. Press back towards the rear of the trailer. The board will begin moving the coupler case (inner slide) into the actuator's outer housing.
5. Keep pressing the top of the board to stroke the actuator and its internal master cylinder. If the trailer brake system is operational, the brakes will apply and keep the trailer from rolling away from you. Properly adjusted uni-servo or duo-servo type brakes will prevent you from moving the trailer back more than a few inches. Free-backing type brakes will initially provide rolling resistance, but continued force on the board will switch them into free-backing mode, and you'll be able to move the trailer backwards.
6. If you have uni-servo or duo-servo brakes, and stroking the actuator (as described previously) causes the trailer to roll away from you freely or with only minimal resistance, the brakes are **NOT** applying properly. If you have free-backing brakes, and stroking the actuator (as described previously) causes the trailer to roll away without initial resistance, the brakes are **NOT** applying properly. The brake system **MUST** be evaluated to determine the cause of the problem, and corrective action **MUST** be taken before the trailer is used.

FIG. 2 - FIELD TEST SETUP

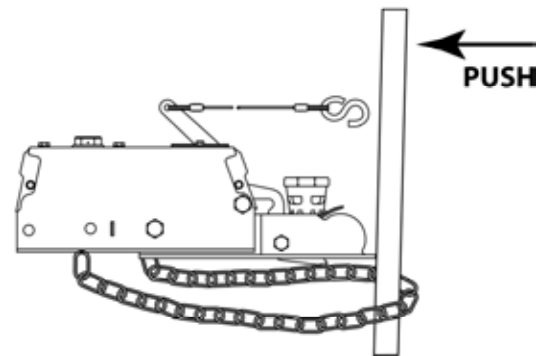

Use this procedure each time you tow your trailer to check your surge brake system operation.

NOTE: <#> Is the reference number shown in the assembly diagram of the actuator located at the end of this manual.

HITCHING TRAILER

⚠ WARNING ⚠

To ensure proper engagement of the actuator's coupler to the tow ball, DO NOT use a multi-piece ball, an incorrectly sized ball, or a worn/damaged ball.

1. Confirm the towing hitch and ball have a rating equal to or greater than the trailer G.V.W.R. and are properly and securely attached to the tow vehicle. The hitch **MUST** be installed so the trailer tongue is level (horizontal) when coupled to the tow vehicle.
2. To attach the actuator to the tow vehicle, follow the procedure below which corresponds to your actuator's coupler type.

2A. MULTI-FIT COUPLER:

The multi-fit (hand wheel) coupler will accept 1-7/8 inch, 50 millimeter, and 2 inch diameter tow balls. Open the coupler by depressing the hand wheel lock <27> and turning the hand wheel <28> fully counterclockwise until its rotation is stopped by the lock ring <29>. Lower the coupler onto the ball, confirming that the ball is fully seated in the coupler socket. Tighten the hand wheel in a clockwise direction to secure the ball. The hand wheel lock should click as you turn the hand wheel, to confirm that the hand wheel will stay tightened. Turn the hand wheel until it can no longer be turned by hand, and then back it off until the lock catches in the nearest notch on the bottom of the hand wheel. Check that the ball latch <25> has been drawn up snugly under the tow ball, trapping it in the coupler socket. Do not tow the trailer if the coupler is damaged.

2B. LEVER-LOCK COUPLER:

The lever-lock coupler is preset at the TITAN factory to fit 2" trailer balls. It can be adjusted to fit 1-7/8 inch or 50 millimeter diameter tow balls by tightening the coupler's locknut <9>, which is underneath the ball latch <25>. After adjustment, make sure that the sides of the locknut is trapped between the flanges of the lock plate <24> so that the locknut can not vibrate loose during trailering. Open the coupler by pressing the handle assembly's <32> lock trigger so it unhooks from the lock plate's loop, and then by swinging the handle forward. Lower the coupler onto the ball, confirming that the ball is fully seated in the coupler socket. Swing the handle upwards until the lock trigger hooks onto the lock plate loop to secure the ball. Check that the ball latch <25> has been drawn up snugly under the tow ball, trapping it in the coupler socket, and that the lock trigger is firmly hooked onto the lock plate loop. A properly adjusted lever-lock coupler will have between 1/64 inch and 1/32 inch of free play between the ball and ball socket. **Do not tow the trailer if the coupler is damaged.**

3. Check that the actuator's coupler is securely latched onto the tow ball by extending the trailer's tongue jack to the ground. Use it to lift the trailer tongue and tow vehicle hitch two to four inches. The coupler and ball should remain engaged. **DO NOT tow the trailer unless the coupler is latched onto the ball securely.** Retract the trailer tongue jack before towing.
4. Confirm the towing hitch and ball have a rating equal to or greater than the trailer G.V.W.R. and are properly and securely

4A. MULTI-FIT COUPLER:

Confirm that the tow ball is fully secured in the coupler as previously described. Insert a standard padlock through the holes in the side of the hand wheel <28>. The padlock will stop against the bracket on top of the couple case <3> and further prevent the hand wheel from rotating and opening. Do not use padlocks which interfere with the telescoping action of the actuator and thereby compromise braking performance.

4B. LEVER-LOCK COUPLER:

Confirm that the tow ball is fully secured in the coupler as previously described. With the handle in the locked CMI! position, insert either a standard padlock or spring pin through the hole in the side of the handle assembly <32>. This will lock the handle to the handle bolt and further prevent the handle assembly from swinging forward and opening. Do not use padlocks or pins which interfere with the telescoping action of the actuator and thereby compromise braking performance.

NOTE: <#> Is the reference number shown in the assembly diagram of the actuator located at the end of this manual.

HITCHING TRAILER (cont.)

**FIG. 3 - SAFETY CHAIN AND BREAK-AWAY CABLE ATTACHMENT
(top view shown)**

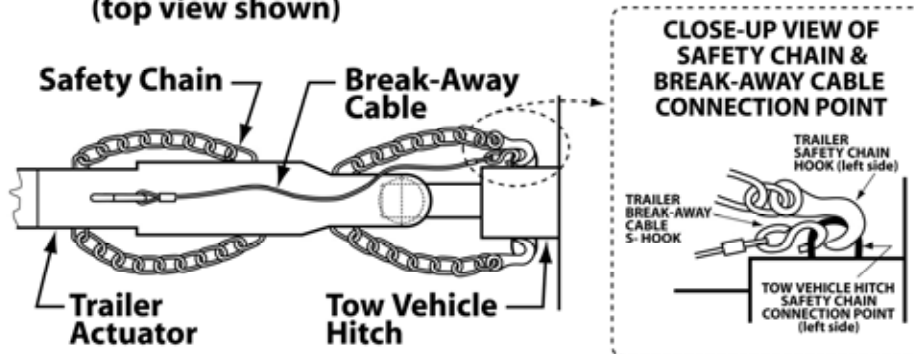

5. As shown in Figure 3, your tow vehicle's hitch provides a safety chain hole or ring on each side. Attach your trailer's safety chains securely to these connection points, being sure to cross the chains UNDER the trailer tongue. Safety chains MUST be used. This will prevent the trailer tongue from dropping to the road if the coupler separates from the tow vehicle's hitch. If your tow vehicle's hitch does not provide safety chain connection points, have appropriate ones added by a reputable hitch installer.
6. Attach the actuator's break-away cable S-hook <11> securely to one of the tow vehicle hitch's safety chain connection points. Confirm that the trailer's safety chains are adjusted relative to the actuator's break-away cable as noted previously. DO NOT loop the break-away cable around a bracket and hook it back onto itself.
7. Before towing, check that the break-away lever assembly <10> is properly positioned as shown on the cover illustration of this manual.

⚠ WARNING ⚠

The trailer safety chains' length MUST be set short enough so the actuator's break-away cable is NOT pulled if the coupler separates from the tow vehicle's hitch but remains connected by the safety chains. The break-away system should only be activated after BOTH the trailer's coupler AND safety chains have failed and allowed the trailer to completely separate from the tow vehicle. Provide just enough slack in the trailer safety chains to allow tight turns. The chains should not drag on the ground. Safety chains must be used.

⚠ WARNING ⚠

The break-away system is not designed to operate if the trailer does not separate completely from the tow vehicle, or if the trailer tongue "submarines" and goes beneath the tow vehicle. DO NOT use the break-away system as a parking brake.

8. Before If the break-away lever and cable are not located correctly, due to either the cable being pulled during use or by accident, it MUST be reset prior to the trailer being moved.

Resetting the Break-away Lever is accomplished by first removing the two screws <31> which retain the cover over the break-away spring <13>. This will allow the cover to be lifted. By pulling the break-away lever <10> slightly further forward, you'll be able to pry the break-away spring carefully out of the notch in the outer case <1> to release the break-away lever. When removing the break-away spring, be careful not to deform it.

⚠ WARNING ⚠

The hydraulic pressure held in the system may cause the lever to snap back quickly. Keep hands and fingers clear as you reset the break-away mechanism.

NOTE: <#> Is the reference number shown in the assembly diagram of the actuator located at the end of this manual.

HITCHING TRAILER (cont.)

8. (cont) Inspect all break-away system components for damage. Replace any damaged items with genuine **TITAN** service parts. With the break-away spring removed, the lever can now be returned to its original position. Check that the tip of the break-away lever which is inside the outer case <1 >, is in **FRONT** of the push rod assembly <14>. Also confirm that the roll-pin, which is pressed through the break-away lever, has remained inside the outer case. Following Figure 4, reinsert the break-away spring into the outer case notch, with the spring flange in the lever's upper detent groove. Replace the cover and fasten it securely with the two screws

If the hydraulic pressure being held in the system is too great to permit the break-away spring to be easily pried out, it can also be released by removing the front roller bolt <8>. This will allow the front of the coupler case <3> to swing down and free the break-away lever. The break-away spring can then be pried out and reset as described above. Be sure to reassemble the rollers <7> with their chamfered ends out against the walls of the coupler case <3>. Tighten the locknuts <9> on the roller bolts <8> just to zero free-play between the outer case <1> and the coupler case <3>, and then back the locknuts off one-half turn. Over tightening will restrict proper surge operation.

FIG. 4 - BREAK-AWAY LEVER

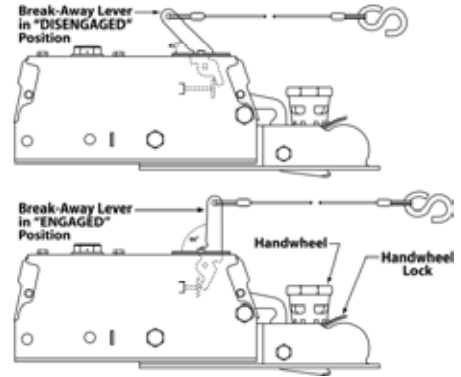

⚠ WARNING ⚠

When towing, AVOID sharp turns which can cause the actuator to bind against the tow vehicle. This can damage the actuator and trailer, causing brake failure. AVOID towing across severe bumps or dips which may cause the tow hitch to lever against the actuator/coupler and compromise the connection between the tow vehicle and the trailer.

⚠ WARNING ⚠

An incorrect lever or chain position may cause the trailer brakes to drag and overheat, or may keep the brakes from being applied in a break-away situation. After any usage of the break-away mechanism, either real or accidental, check all system components (lever, chain, cable, S-hooks, break-away locks, and break-away bolts etc.) for damage. Replace any damaged items with genuine TITAN service parts.

10. Sway control devices that restrict operation of the actuator CANNOT be used. The actuator MUST be free to telescope in response to braking requirements.
11. The actuator is designed for use with Free-Backing or Uni-Servo drum style trailer brakes. Do not block the surge action in order to back up with other brake types due to potential system damage. Failure to remove block will also prevent forward braking.
12. To uncouple the trailer, first block the wheels to keep the trailer from rolling. Unhook the actuator's breakaway cable and the trailer's safety chains from the tow vehicle. Then open your coupler as described previously in the section which corresponds to your actuator's coupler type. Finally, lift the trailer tongue off the tow ball, using a tongue jack if necessary.

NOTE: <#> Is the reference number shown in the assembly diagram of the actuator located at the end of this manual.

MAINTENANCE

1. Before each towing, perform the following steps:

- Check that the brake fluid reservoir is three-quarters full of DOT-3 or DOT-4 brake fluid. Check for leaks and repair as required.

⚠ WARNING ⚠

Use only fresh brake fluid from a sealed container. DO NOT reuse fluid. After filling and bleeding, remember to refill the actuator. Failure to maintain an adequate fluid level may cause brake failure.

- Examine the actuator for wear, bent parts, corroded/seized parts, or other damage. Have the affected components replaced with genuine TITAN service parts. Check to determine that the actuator mounting bolts (where applicable) are tightened to eighty (80) foot-pounds torque using a torque wrench.
 - Test the actuator and brake function as described in the "TESTING TITAN SURGE BRAKE SYSTEMS" section of this manual. Actuator travel over one inch indicates that the brakes need adjustment (or that the actuator has been structurally damaged). Actuator travel is the distance the coupler case assembly <3> moves relative to the outer case <1> during braking. Adjust the brakes following the instructions given in the brake installation manual. In general, back off adjusters ten clicks from locked drum rotation. Adjust free-backing brakes by rotating in the forward direction only. Failure to adjust brakes will result in loss of braking.
2. The only adjustments on the actuator itself are the self-locking nuts <9> on the two roller bolts <8>. Tighten the Locknuts just to zero free-play between the outer case <1> and the coupler case <3>, and then back the locknuts off one-half turn. Over-tightening will restrict proper surge operation.
3. A film of clean grease on the ball will minimize squeaking. Wipe the ball clean and renew film each time the trailer is used.
4. Before towing, examine the actuator for bent parts or wear. Replace parts as necessary. Check to determine that mounting bolts are tight and welds not cracked.
5. Actuator travel (over one inch) shown by front roller path indicates a need to adjust the brakes. Adjust per instructions found in brake installation manual. In general, back-off adjusters 10 clicks from locked rotation. Adjust Free-Backing brakes by rotating in forward direction only. Failure to adjust may result in loss of braking.
6. Before storage or after extended use, TITAN recommends applying motor oil to the coupler components and internal rollers to keep them moving freely and to prevent corrosion.

MODEL 60 PRODUCT LIST

DESCRIPTION	DRUM BRAKE		DISC BRAKE	
		w/90 degree elbow		w/90 degree elbow
Lever lock, plated	4332900	4332901	4715400	4715401
Lever lock, painted	4338600	4338601	4819900	4819901
Multi-fit plated	4339700	4339701	4745700	4745701
Multi-fit painted	4339900	4339901	4815200	4815201
Master cylinder	2336100042		4714200042	

NOTE: <#> Is the reference number shown in the assembly diagram of the actuator located at the end of this manual.

MODEL 60 ACTUATOR PARTS LIST

Ref No.	Part No.	Description	Multi-Fit Marine 43397, 47457	Multi-Fit Painted 43399, 48152	Lever-Lock Marine 43329, 47154	Lever-Lock Painted 43386, 48199
1	4324600	Outer Case	1		1	
1	4338700	Outer Case		1		1
2	2337700	Strut	1	1	1	1
3	2337800	Coupler Case	1			
3	4097000	Coupler Case		1		
3	4332500	Coupler Case			1	
3	4338800	Coupler Case				1
4	2336200	Shock Absorber	1	1	1	1
5	2339000	Bolt, Hex 7/16 NF x 2-5/8	1	1	1	1
6	2339100	Locknut, Hex 7/16 NF Thin	1	1	1	1
7	2327800	Roller	4	4	4	4
8	2341300	Bolt, Hex 1/2 NF x 3-3/4	2	2	2	2
9	1861200	Locknut, Hex 1/2 NF	2	2	3	3
10	4623800	Breakaway Assy. w/pin, cover, s-hook	1	1	1	1
11	1055500	S-hook - included with 46238	1	1	1	1
13	4005200	Breakaway Spring	1	1	1	1
14	2346300	Push Rod Assembly	1	1	1	1
15	* 2336100042	Master Cylinder - Drum Brake	1	1	1	1
15	* 4714200042	Master Cylinder - Disc Brake	1	1	1	1
16	* 2341400	Gasket	1	1	1	1
17	* 1209800	Connector, 1/64" orifice - Drum Brake	1	1	1	1
17	* 4750300	Connector - Disc Brake	1	1	1	1
18	* 1050800	Bolt, Hex 1/4 NC x 3/4	4	4	4	4
19	* 07994000	Lock washer 1/4	4	4	4	4
20	* 4480701	Filler ap, 1-1.4-18 NEF plastic	1	1	1	1
21	* 2338900	Gasket, Filler Cap	1	1	1	1
22	* 2356600	Cover, Master Cylinder	1	1	1	1
23	2338100	Latch Bolt	1	1		
24	1809000	Lock Plate	1	1	1	1
25	4335800	Ball Latch	1	1	1	1
26	4336800	Spring	1	1	1	1
27	2338300	Hand Wheel Lock	1	1		
28	2420000	Hand Wheel	1	1		
29	2496400	Lock Ring	1	1		
30	2452500183	Cover, Front	2		2	
30	2452500317	Cover, Front		2		2
31	1094100	Screw, Cover	6	6	6	6
32	4358500	Handle Assembly			1	1
33	4334500	Spring Plate			1	1
34	4045400	Multi-Fit Coupler Repair Kit	1	1		
35	4358400	Lever-Lock Coupler Repair Kit			1	1
36	1502600	Master Cylinder Repair Kit Wagner	1	1	1	1
37	4395100	Master Cylinder Kit (includes * parts) Drum Brakes	1	1	1	1
37	4820000	Master Cylinder Kit (includes * parts) Disc Brakes	1	1	1	1

NOTE: <#> Is the reference number shown in the assembly diagram of the actuator located at the end of this manual.

MODEL 60 PARTS DIAGRAM

MULTI-FIT
MODEL 60 ACTUATOR DIAGRAM

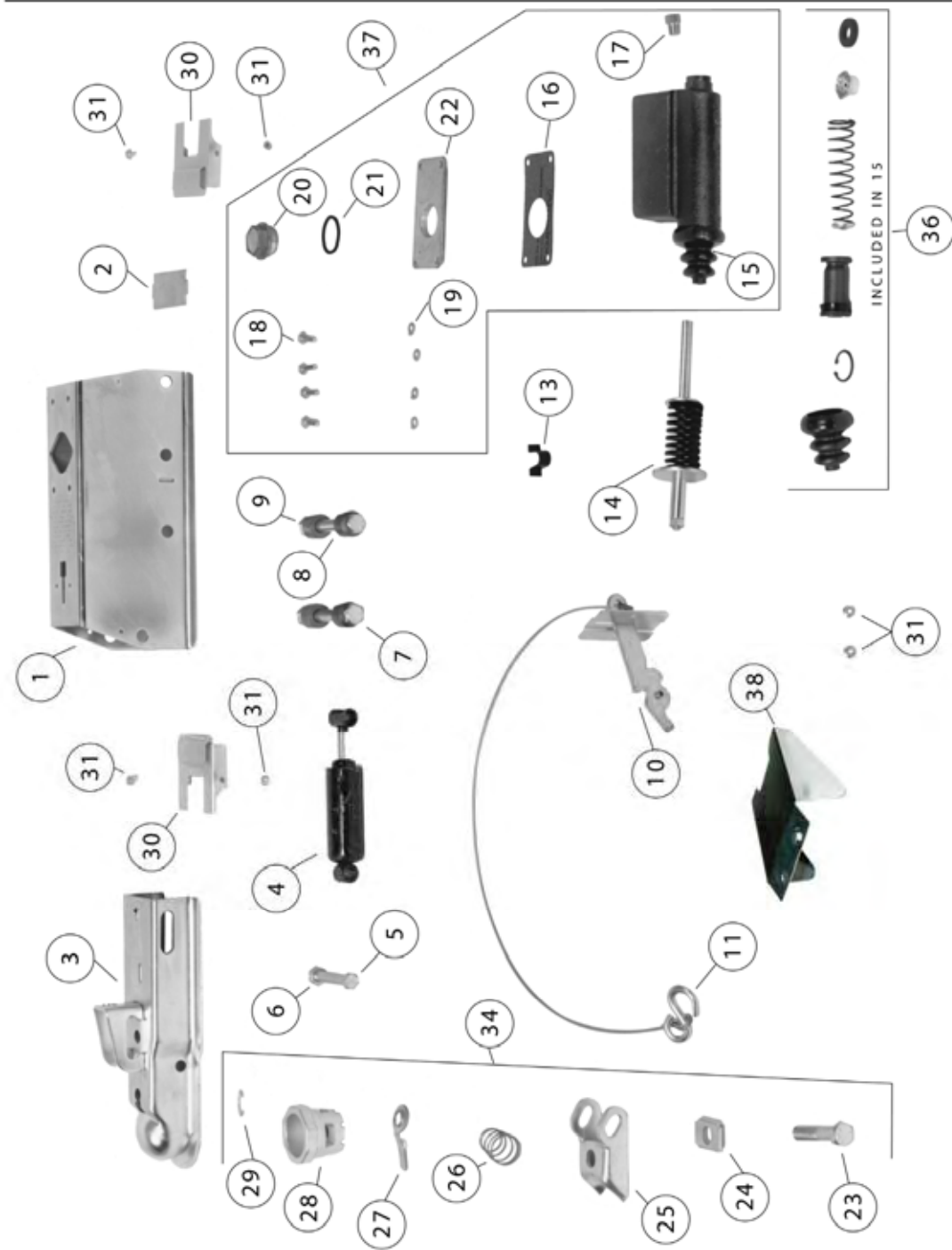

MODEL 60 PARTS DIAGRAM (cont.)

LEVER-LOCK
MODEL 60 ACTUATOR DIAGRAM

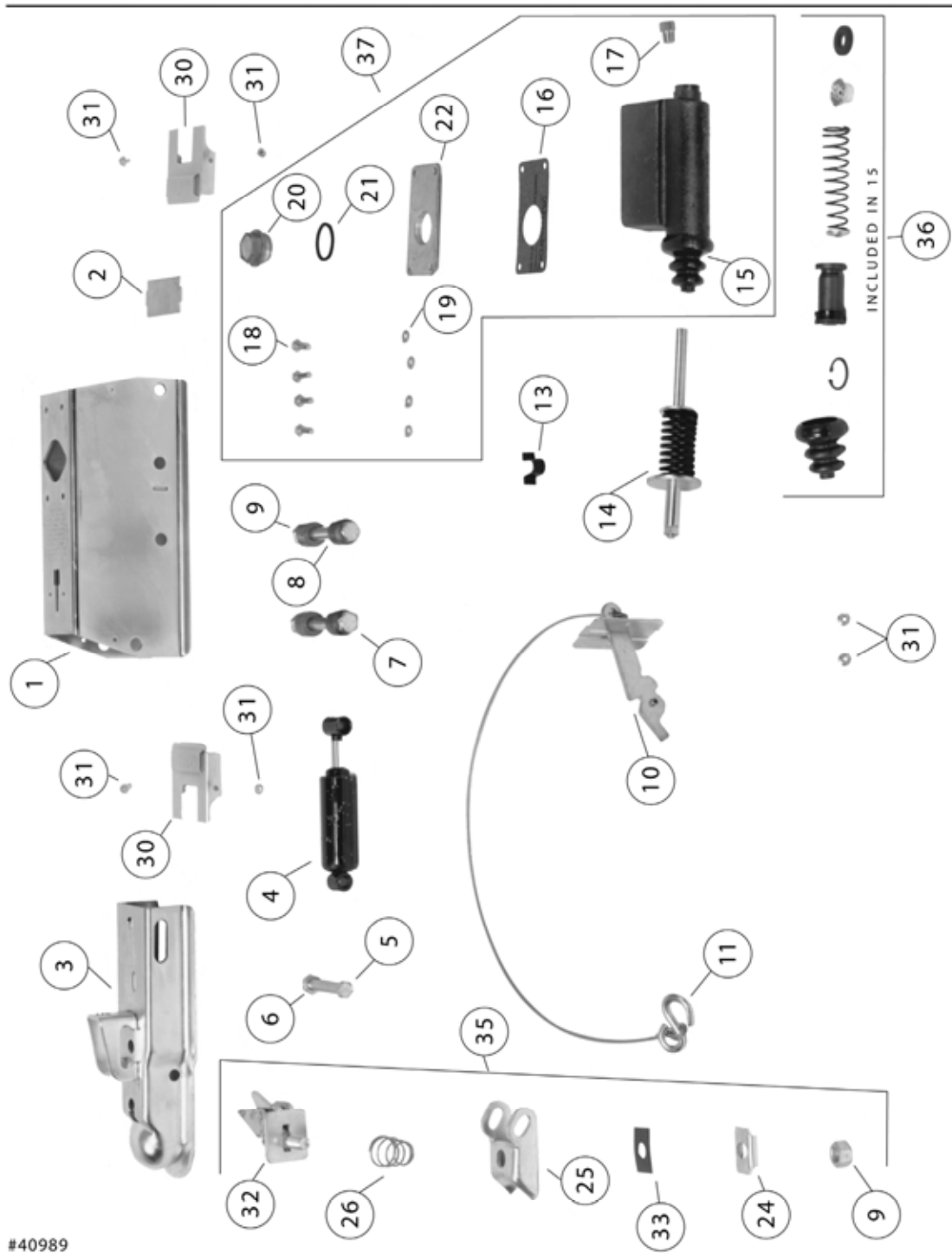

#40989



LIMITED WARRANTY

Limited Warranty Titan Tire Corporation (TITAN) warrants its products to be free from defects in material and workmanship for one year from date of delivery to the original purchaser when properly installed, used and maintained by the purchaser.

This warranty does not apply to damage or loss caused by any or all of the following circumstances or conditions:

- Freight damage.
- Parts, accessories, materials or components not obtained former approved in writing by TITAN.
- Misapplication, misuse and failure to follow the directions or observe cautions and warnings on installation, operation, application, inspection or maintenance specified in any TITAN quotations, acknowledgements, sales literature, specification sheet or installation instructions and service manual ("applicable literature")

If any TITAN products are found upon TITAN's examination to have been defective when supplied, TITAN will either: credit the purchaser's account for the purchase price of the TITAN product; or repair the product. TITAN has sole discretion in choosing which option to provide. For this LIMITED WARRANTY to apply, TITAN must receive notice of the alleged defect within 30 days of either the discovery of the alleged defect or the expiration of the warranty period, whichever is earlier. Any claim not made with in this period shall conclusively be deemed waived.

If requested by TITAN, purchaser shall return the alleged defective product to TITAN for examination at Titan's direction and expense. TITAN will not pay for expenses incurred in returning a product to TITAN without TITAN'S prior written authority. TITAN shall not be liable for any other expenses purchaser incurs to remedy any defect. Purchasers waive subrogation on all claims under any insurance.

Limitation of Liability It is expressly agreed that the liability of TITAN is limited and TITAN does not function as an insurer. THE REMEDIES SET FORTH IN THIS WARRANTY SHALL CONSTITUTE THE EXCLUSIVE REMEDIES AVAILABLE TO THE PURCHASER OR USER AND ARE IN LIEU OF ALL OTHER REMEDIES, EXPRESS OR IMPLIED. THE LIABILITY OF TITAN, WHETHER IN CONTRACT, IN TORT, UNDER ANY WARRANTY OR OTHERWISE, SHALL NOT EXCEED THE PURCHASE PRICE OF THE PARTICULAR PRODUCT MANUFACTURED, SOLD OR SUPPLIED BY TITAN.

To Obtain Technical Assistance To enable TITAN to respond to a request for assistance or evaluation of customer or user operation difficulty, please provide at a minimum the following information by calling 1-800-872-2327 or within Iowa 1-515-265-9200:

- Model number, serial number and all other data on the specific component which appears to be involved in the difficulty.
- The date and from whom you purchased your TITAN product.
- State your difficulty, being sure to mention at least the following: Application, Nature of load involved, and Weight of the load.

Field Service If field service at the request of the purchaser is rendered and the difficulty is found not to be with TITAN'S product, the purchaser shall pay the time and expense (at the prevailing rate at the time of service) of the seller's field representative(s). Charges for service, labor and other expenses that have been incurred by the purchaser, its customer or agent without prior written authorization of TITAN will not be accepted.

TITAN EXTENDS NO WARRANTY, EXPRESS OR IMPLIED, ON PRODUCTS NOT MANUFACTURED BY TITAN OR TO TITAN'S DESIGN SPECIFICATION, INCLUDING BUT NOT LIMITED TO SUCH ITEMS AS NON-TITAN TIRES, BRAKES, ACTUATORS, BEARINGS, HOSE AND TUBING, PURCHASER'S RECOURSE SHALL BE LIMITED TO ANY WARRANTY OF THE PERSPECTIVE MANUFACTURERS.

THIS WARRANTY EXCLUDES ALL IMPLIED WARRANTIES OF MERCHANTABILITY OR FITNESS FOR A PARTICULAR PURPOSE OR ANY PURPOSE.

THIS WARRANTY DOES NOT COVER NOR EXTEND TO INCIDENTAL OR CONSEQUENTIAL DAMAGE. Some states do not allow the exclusion or limitation of incidental or consequential damages, so the above limitation or exclusion may not apply to you.

No representative has authority to make any representation, promise or agreement except as stated in this Limited Warranty. TITAN reserves the right to make design and other changes upon its products without any obligation to install the same on any previously sold or delivered products.

THERE ARE NO WARRANTIES WHICH EXTEND BEYOND THOSE DESCRIBED ABOVE. EFFECTIVE JANUARY 1, 1998 THIS WARRANTY SUPERSEDES ALL PRIOR WARRRANTIES, WRITTEN OR IMPLIED.