

# INSTALLATION INSTRUCTIONS

VEHICLE

KIA RIO & CINCO

**EQUIPMENT REQUIRED:**

**WIRING ACCESS LOCATION:** PC3, PC4

**DRILL BITS:** 1/2"

**HITCH REQUIRES 1/2" PIN AND CLIP**

**WRENCHES:** (TIGHTEN ALL FASTENERS WITH TORQUE WRENCH) 3/4"

2000 LB MAX GROSS TRAILER WT  
200 LB MAX TONGUE WEIGHT  
DO NOT EXCEED TOWING VEHICLE RATINGS

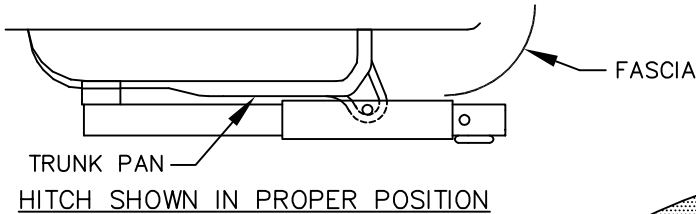

REMOVE SPARE TIRE BEFORE DRILLING!

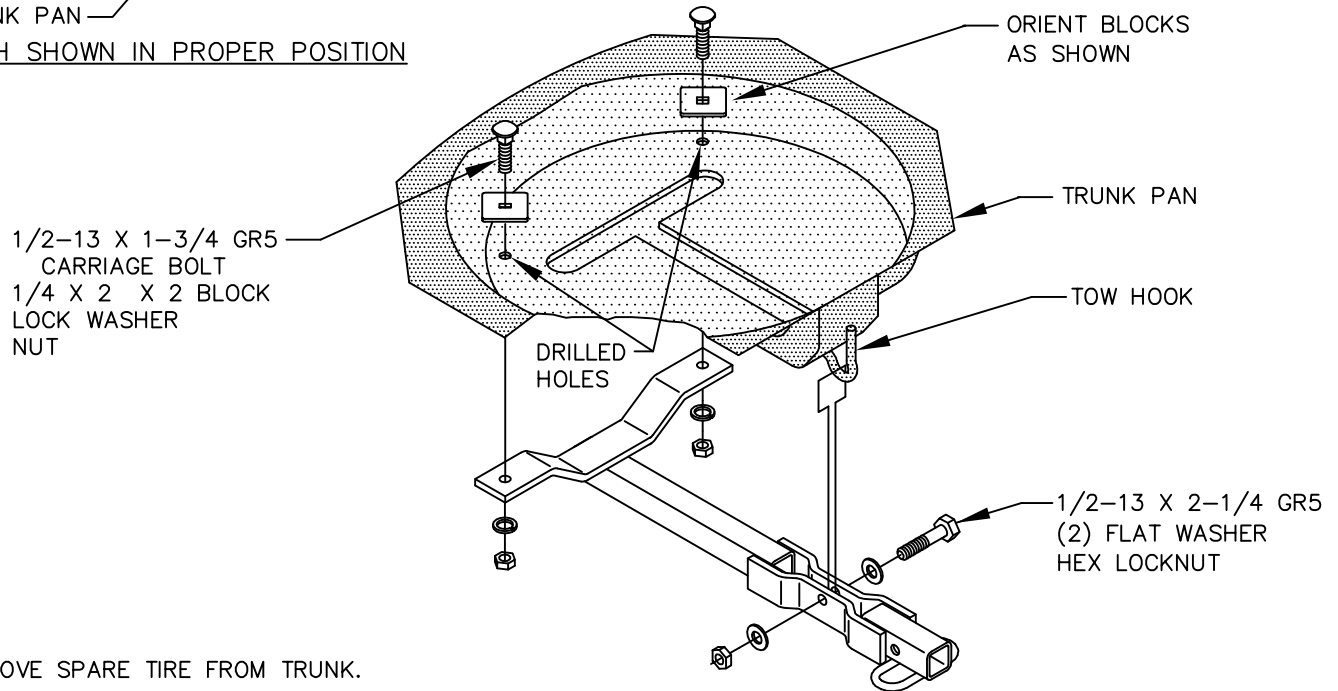

1. REMOVE SPARE TIRE FROM TRUNK.
2. ATTACH HITCH TO TOW HOOK AS SHOWN ABOVE.
3. USING HITCH AS TEMPLATE, DRILL TWO (2) 1/2" HOLES IN TRUNK PAN.
4. INSTALL 1/2-13 BOLTS, BLOCKS, LOCK WASHERS AND NUTS AS SHOWN ABOVE.
5. SEAL HOLES DRILLED IN TRUNK PAN TO PREVENT INTRUSION OF EXHAUST FUMES AND WATER.
6. REINSTALL SPARE TIRE IN TRUNK.

TIGHTEN ALL 1/2 GR5 FASTENERS TO 75 LB.-FT.

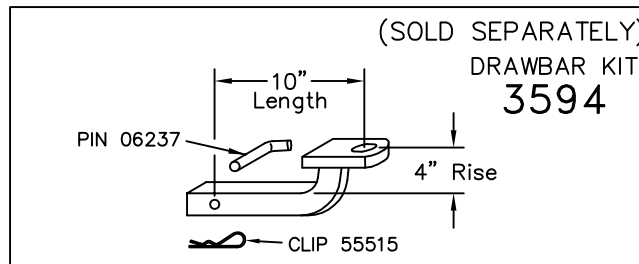

USE ONLY THE DRAWBAR SHOWN FOR CORRECT BUMPER CLEARANCE AND HEIGHT.  
DRAWBAR MUST BE USED IN THE RISE POSITION ONLY.

THIS PRODUCT COMPLIES WITH SAFETY SPECIFICATIONS AND REQUIREMENTS FOR CONNECTING DEVICES AND TOWING SYSTEMS OF THE STATE OF NEW YORK, V.E.S.C. REGULATION V-5 AND SAE J684.

APPROX WEIGHT (LB.)	FASTENER KIT
14.5	F24727

**NOTE:** Check hitch frequently, making sure all fasteners and ball are properly tightened. If hitch is removed, plug all holes in trunk pan or other body panels to prevent entry of water and exhaust fumes. A hitch or ball which has been damaged should be removed and replaced. Observe safety precautions when working beneath a vehicle and wear eye protection. Follow car maker's specs for maximum trailer weight and tongue weight. Do not cut access or attachment holes with a torch.

**TOWING PRODUCTS**  
Plymouth, Michigan