

IX. TROUBLESHOOTING (CONT.)

PROBABLE CAUSE	REMEDY
Problem: One Brake Overheating, Side Pull, Poor Brake Performance.	
Caliper piston not retracting.	<ol style="list-style-type: none"> 1. Check for foreign material in brake line. 2. Corrosion between caliper and piston. 3. Check for proper movement on guide bolt sleeves. 4. Check and rebuild or replace caliper.
A bent guide bolt/caliper mounting bracket.	Replace as required.
Side pull.	Check wheel bearings, caliper, rotor, and replace as required.
Problem: All Brakes Overheating, Poor Brake Performance.	
* Breakaway cable partially engaged.	Inspect and release breakaway cable per manufacturer's recommendations.
Foreign material in brake line.	Flush and clean thoroughly. Re-bleed system.
Low hydraulic fluid level.	Fill with new brake fluid per actuator manufacturer's specifications.
Air in brake system.	Bleed brakes to eliminate any trapped air.
Broken or pinched brake lines.	Replace or repair as required.
*Brake actuator frame damaged	Replace actuator.
Residual pressure in brake line.	See Section V, Note 3 for surge braked trailer. Check operating manual for Electric/Hydraulic actuators.

* For trailers with surge brake actuators only.

IMPORTANT SAFETY NOTICE

Appropriate installation, maintenance, and repair procedures are essential for the safe, reliable operation of vehicle brakes, as well as the safety of the individual doing the work. This booklet provides general information in this regard.

There are numerous variations in procedures, techniques, tools, and parts for servicing brakes, as well as in the skill of the individual doing the work. This booklet cannot possibly anticipate all such variations and provide advice and caution as to each. Accordingly, anyone who undertakes to install, maintain, or repair a vehicle brake system or brake system components, must first establish that they neither compromise their personal safety nor the vehicle integrity by their choice of methods, tools or parts.

Refer to your trailer manufacturer's owner's manual for additional safety and procedural information prior to performing any installation,

KODIAK TRAILER COMPONENTS
7600 SAND STREET
FORT WORTH, TX 76118
800-7KODIAK
www.kodiaktrailer.com



Trailer Disc Brakes

Installation/Operating Information

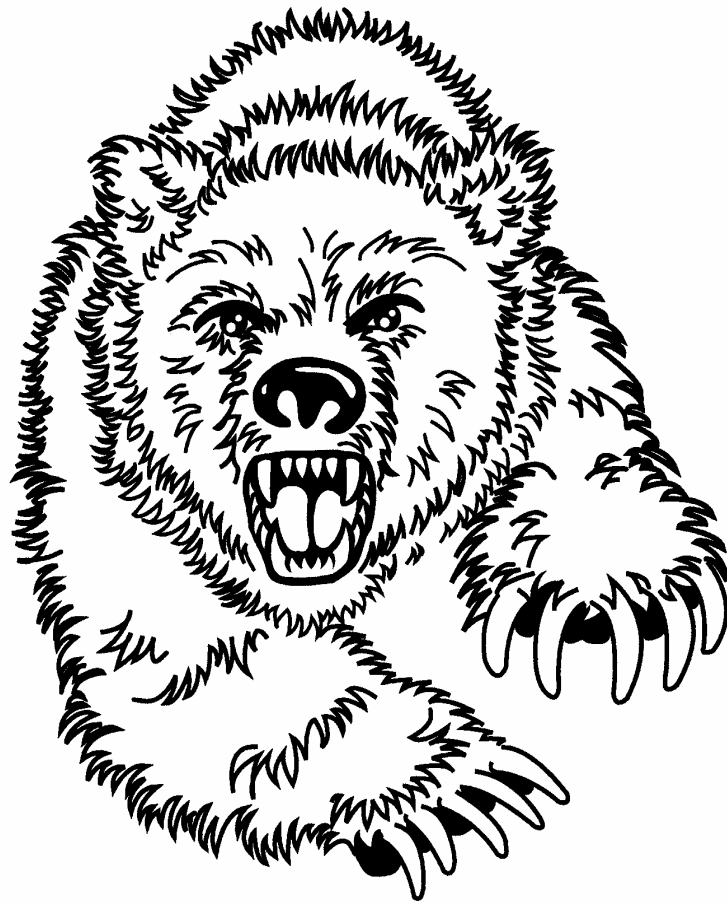

KODIAK TRAILER COMPONENTS
7600 SAND STREET, FORT WORTH, TX 76118
800.7.KODIAK
(800.756.3425)

www.kodiaktrailer.com

IX. TROUBLESHOOTING

PROBABLE CAUSE	REMEDY
Problem: Can Not Back Up Surge Braked Trailer.	
12 v. solenoid valve is inoperative	<ol style="list-style-type: none"> 1. Check tow vehicle back-up light circuit. Check 12v. Solenoid. (Should be able to hear a "click" when 12 v. DC is applied to lead wire.) 2. Check connection to tow vehicle back-up light circuit. 3. Check trailer ground connection (do not depend on hitch ball connection to provide ground). Trailer should have dedicated ground wire connected to grounding lug.
Problem: Squeaking, Clatter or Chucking.	
* This could be caused by a worn out shock absorber in the Surge Brake Actuator.	Replace per manufacturer's specifications.
* The linkage and pivots on the brake actuator.	Lubricate per manufacturer's specifications.
Loose hitch ball.	Inspect hitch ball and tighten or replace as required.
Loose hitch.	Inspect hitch and tighten or replace as required.
Hitch ball worn or too small.	Replace with properly sized and rated ball.
* A bent push rod in the shock absorber.	Replace per manufacturer's specifications.
* A bent master cylinder actuating rod.	Replace per manufacturer's specifications.
* A damaged coupler assembly.	Replace per manufacturer's specifications.
Broken rotor.	Replace rotor and check caliper.
*Low brake fluid level in reservoir.	<ol style="list-style-type: none"> 1. Fill and bleed brakes. 2. Replace or rebuild actuator master cylinder.
Worn out caliper pads.	Replace caliper pads and check rotors.
Leaky caliper.	<ol style="list-style-type: none"> 1. Check tightness of brass adapter between brake line and caliper housings. 2. Replace or rebuild calipers. 3. Clean other hardware.
Leaky wheel bearing grease seal.	Replace grease seal and wheel bearings as required. Pack wheel bearings. Re-bleed as necessary. Clean other hardware.
Caliper/Mounting bracket bolts may be loose.	Tighten to manufacturer's specifications and/or replace as necessary.
Caliper guide bolts may be loose.	<ol style="list-style-type: none"> 1. If threads in caliper mounting bracket are deformed, replace bracket. 2. Apply thread locker to M17X1.5 guide bolt and torque to 40 - 45 foot pounds.
Spindle nut may be loose.	Tight to manufacturer's specifications and/or replace as necessary
Lug nuts may be loose.	Torque to manufacturer's specifications and/or replace as necessary.

* For trailers with surge brake actuators

Troubleshooting Continued On Next Page

VIII. REPLACEMENT PARTS

1. CALIPER - The Kodiak caliper will accommodate GM replacement friction pads which should be available at your local auto parts store. Specify pad #D-289 for Model #225 (same pads used for 1980-1990 Buick Skylark-front) and #MD-215 semi-metallic for Model #250 (same pads used for 1983-1995 Buick Century H/D-front). Specify Pad #D459 for Model #338 (same pads used for Chevrolet Pickup K30, K3500 4WD 1992 - 2001 dual rear).

2. OTHER ITEMS - The caliper fittings (which are brass for corrosion resistance), rotor, and caliper mounting brackets are all specially designed to fit standard trailer hubs and axles. Accordingly, these items are not standard automotive parts, and may be sourced from your trailer parts dealer, distributor, or mass merchandiser. Kodiak also offers parts replacements through its customer service department at 1-800-7KODIAK or at Kodiak's online store at www.kodiaktrailer.com. (Click on Store.)

PARTIAL BRAKE PARTS LIST	
ITEM DESCRIPTION	KODIAK PART #
10" rotor (e-coated), fits 545 hub	ROTOR-10-E
10" rotor (stainless steel), fits 545 hub	ROTOR-10-SS
10" integral hub and rotor (e-coated), 545 bolt pattern	ROTOR/HUB-10-E
12" rotor (e-coated), fits 655 hub	ROTOR-12-E
12" rotor (stainless steel), fits 655 hub	ROTOR-12-SS
12" integral hub and rotor (e-coated), 655 bolt pattern	ROTOR/HUB-12-E
13" rotor (e-coated), fits 865 hub, 1/2" wheel bolts (for 7K axle)	ROTOR-133-7-8-E
13" rotor (e-coated), fits 865 hub, 9/16" wheel bolts (for 8K axle)	ROTOR-133-8-9-E
13" rotor (e-coated), fits 865 hub, 5/8" wheel bolts (for 8K axle)	ROTOR-133-8-10-E
Loaded caliper, fits 10" & 12" vented rotor	DBC-225-E
Replacement ceramic friction pads for DBC-225-E	DBC-225-CERM-PAD
Loaded caliper for 13" vented rotor with ceramic pads	DBC-250-E
Replacement ceramic friction pads for DBC-250-E	DBC-250-CERM-PAD
Loaded caliper for 9K & 10K axles with a 3-3/8" piston	DBC-338-E
Replacement ceramic friction pads for DBC-338-E	DBC-338-CERM-PAD

For replacement part numbers not listed above, you can view the information online at www.kodiaktrailer.com or contact Customer Service.

CONTENTS

SECTION

- I. INTRODUCTION
- II. GENERAL INFORMATION
- III. SAFETY INFORMATION
- IV. INSTALLATION INFORMATION
- V. SOLENOID REVERSING VALVES
(SURGE BRAKED TRAILERS ONLY)
- VI. BLEEDING THE BRAKES
- VII. PREVENTATIVE MAINTENANCE CHECKLIST
- VIII. REPLACEMENT & REPAIR PARTS
- IX. TROUBLESHOOTING
- X. WARRANTY INFORMATION (ENCLOSED)

I. INTRODUCTION

CONGRATULATIONS!

Your selection of Kodiak Trailer disc brakes is an excellent choice. Disc brakes offer improved performance, longer life, and minimum maintenance when compared to drum brakes. As you will note, Kodiak's design is focused on trailer applications under 26,000 pounds, and includes hardware, fittings, fasteners, and coatings that will provide years of dependable service. The Kodiak Trailer Disc Brake System is a proven system that includes a ventilated rotor, combined with a caliper and mounting bracket that attach to the axle end assembly by bolting to the standard brake flange. The following information may be of benefit to you during installation, maintenance, or repair, and should be retained with your other trailer records.

II. GENERAL INFORMATION

Kodiak offers two types of rotors. The first type is a rotor only, which fits over a standard idler hub. This type of rotor installation has been used by major automobile manufacturers and others for many years. The wheel studs are pressed into the hub only. The rotor is a loose fit on the hub, is centered by the wheel bolts, and is retained by the wheel, which in turn is retained by the wheel nuts. Removal of the rotor can be accomplished with little effort once the caliper has been removed. No machining is required prior to installation.

Kodiak also furnishes an integral (one piece) hub and rotor. In this type, the rotor and hub are cast as a single unit. Wheel studs and bearing races are pressed in.

Note: This booklet is designed to give information on both types of rotors. Please note that information that is applicable only to the first type of rotor (rotor only) will be italicized in this booklet.

4. After bleeding is completed, make sure the master cylinder reservoir is filled and all bleeder screws are tight.

Notes:

1. On the 3500 lb. through 8000 lb. axles, **Caliper should be installed so that bleeder screw is always pointing up** to properly expel entrapped air. On the 9000 lb. and 10,000 lb. axles, **Caliper should be installed with the caliper mounted at 12 o'clock position.**
2. This is a high pressure brake system, which will not function properly with **any** air in the system. Be sure to bleed brake system thoroughly.
3. **Kodiak recommends bleeding the system again after the first 100 miles of towing.**

VII. PREVENTIVE MAINTENANCE CHECKLIST

1. Visually check brakes before each trip. See Section III, Paragraph 6.
2. After each hook-up, always check trailer brake operation before attaining normal driving speed.
3. Follow manufacturer's recommendations with regard to use of and replacement of brake fluid. Three important points to remember: (1) Brake fluid can cause paint damage; (2) use new fluid and keep it clean; and (3) brake fluid is hydroscopic (i.e., it will absorb water from the atmosphere). Change and flush system per actuator manufacturer's recommendations.
4. Wash down brake assembly immediately after exposure to salt water or other corrosives.
5. Periodically, during each trip, check hub and assemblies to make sure that there is no excessive heat. Do not touch brake components, as they may be much hotter than the hub or wheel, especially after recent braking. Do not perform this check after recent, severe, or prolonged braking.

NOTES (Cont.):

6. Since the reversing valve is operated by the tow vehicle's back up light circuit, never tow a surge braked trailer if the tow vehicle's back up light circuit is **ON** at any time other than when the tow vehicle transmission is in reverse.
7. When bleeding a brake system that includes a normally closed solenoid reversing valve, bleed at least one cycle with 12 volts applied to the solenoid. This will eliminate the possibility of trapping air at the valve.

VI. BLEEDING THE BRAKES

1. Follow actuator manufacturer's recommendations to pressurize the brake lines.

Notes:

(a) Air bubbles will tend to rise to the highest point in the brake line; therefore, check to make sure the brake lines are run as level as possible to avoid high spots which may trap air. Also, with surge brake actuators, make sure the calipers are as high as possible, and the actuator is as low as possible when pressure bleeding.

(b) Kodiak recommends use of a small bleeder hose that will fit over the bleeder screw. Have the loose end of hose submerged in a clear container of brake fluid to observe bubbling.

2. Install bleeder hose on bleed screw on its first caliper to be bled (this is normally the caliper farthest from the actuator).
3. After the system is pressurized, open the bleeder screw (located in the caliper) one turn. The trapped air and pressurized brake fluid will be vented into the atmosphere through the passage drilled in the screw. The bleeding operation is complete only when all entrapped air is removed from system. Be sure to close bleeder screw securely after each compression stroke of the master cylinder push rod or actuation of the electric/hydraulic actuator during the bleeding process.

III. SAFETY INFORMATION

1. Brake installation, maintenance or repair on any vehicle should be performed only by qualified persons who are knowledgeable of brakes and brake systems. Read "Important Safety Notice" on back cover.
2. Familiarize yourself with your state laws regarding the operation of towed vehicles, especially with regard to brake/braking requirements. Allow for the extra stopping distance that may be required when towing.
3. Make sure the trailer is properly and safely supported at all times during brake installation, maintenance or repair.
4. Immediately after each hookup, always test and confirm that trailer brakes are operating properly before attaining normal road speed.
5. As a general rule, disc brakes require more hydraulic pressure to operate than drum brakes. Confirm that the hydraulic brake actuator that you plan to use to actuate the disc brakes, will generate adequate hydraulic pressure for your purposes.
6. Make regular periodic inspections of your trailer brakes. The inspection should include:
 - (a) Pads - for evidence of excessive or uneven wear.
 - (b) Rotors - for evidence of excessive wear, scoring, excessive heat build up, cracks, warpage.
 - (c) Brake Fluid Reservoir - proper fluid level.
 - (d) All Bolted Connections - tight.
 - (e) Calipers and Brake Lines - for evidence of brake fluid leaks.

Note: Inspect brake system, including friction pads prior to each use. Rotor damage from excessive pad wear (i.e., "metal to metal" damage) is not covered by product warranty.

IV. INSTALLATION INFORMATION

Installation of Kodiak trailer disc brakes is fairly straight forward. Please note Fig. 1 below:

- | | |
|--|-------------------|
| 1. Spindle (Welded to trailer axle) | 9. Outer Bearing |
| 2. Cotter Key | 10. Flat Washer |
| 3. Brake Flange (Welded to spindle ★) | 11. Retainer Unit |
| 4. Calipers (Bolted to mounting bracket ⊕) | |
| 5. Caliper Mounting Bracket (Bolted to brake flange ●) | |
| 6. Inner Bearing | |
| 7. Hub | |
| 7a. Wheel Bolt | |
| 8. Rotor | |
| 8a. Rotor/Hub (Integral) | |

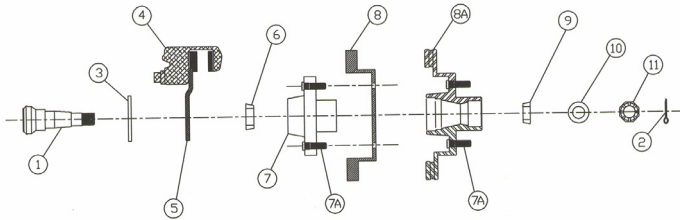
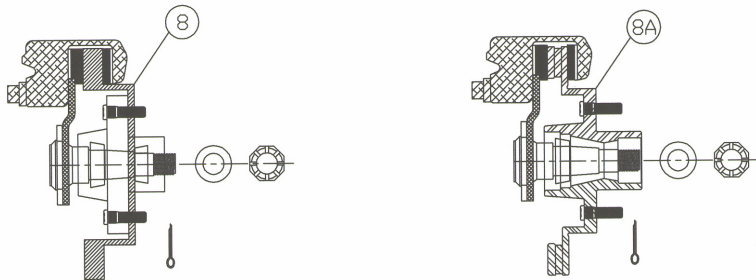

Fig. 1 Exploded View (Seals Not Shown)

Assembled View



Normally Closed - This solenoid valve is typically plumbed from a “Tee” that is screwed into the master cylinder. (Note: There are “three port” valves available that eliminate the need for a tee.)

From the valve, a “return line” must be installed to dump the brake fluid back into the master cylinder reservoir.

Advantages: Eliminates the problems listed under Disadvantages on previous page.

Disadvantages: Requires a few additional fittings, a short length of brake line, and may require drilling and tapping an access hole in the master cylinder reservoir for the “return line.”

NOTES:

- Solenoid valves may be one wire (internally grounded case) or two wires (ungrounded case). On a two wire model, generally either wire can be grounded and either wire may be connected to a 12 vdc. Polarity is not a problem.
- Solenoid valves should have an “in” and “out” marked on the housing. This configuration *must be observed* when piping a solenoid valve. It will not work properly otherwise.
- No Residual Line Pressure - The older hydraulic drum brake systems require that a 10 - 12 psi residual pressure be maintained in order to keep the wheel cylinder piston seals seated. To accomplish this, many surge brake actuators have a small diaphragm type check valve installed just inside of master cylinder output port.
- The orifice in the solenoid is on the order of 0.030” in diameter. Be careful not to introduce any foreign material into the brake line while installing the valve. If could later plug or partially plug the orifice and cause the calipers not to completely release, which, in turn, will cause overheating.
- Disc brake systems *must not* be subjected to any residual brake line pressure (it will overheat the brakes and hubs). Therefore, make sure (1) you are using a surge brake actuator that is designed specifically for disc brake applications, or (2) that the diaphragm check valve on the drum brake version is rendered inoperative (an ice pick or awl can be used to perforate the diaphragm).

V. SOLENOID REVERSING VALVES (FOR SURGE BRAKED TRAILERS ONLY)

WHY IS A REVERSING VALVE NEEDED?

For surge braked trailers, a reversing valve is recommended to facilitate backing up the trailer. This is necessary because disc brakes function equally well in either direction, unlike uni-servo drum brakes.

Note: Uni-servo drum brakes need very little hydraulic pressure to activate them while going forward, but a tremendous amount of pressure is required to operate the brakes in reverse. Therefore, many users simply overpower the brakes (or purchase free backing brakes) when backing up.

Some surge disc brake actuator's have normally closed solenoid reversing valves factory installed as standard equipment. Other surge brake actuators do not, and will require the installation of a solenoid reversing valve. These solenoids are energized by connecting them to the tow vehicle's back-up light circuit. The solenoids come in two types:

Normally Open - This solenoid valve is installed "in-line," normally near the master cylinder.

Advantages:

- (1) Quick and easy to install.

Disadvantages:

- (1) If trailer is stopped in a downhill attitude, some positive pressure will remain in the brake line. When the back-up light is energized, the solenoid valve merely "traps" the pressurized brake fluid, which may or may not prohibit backing up the trailer.

- (2) If trailer hits any significant object (such as a curb) while in the process of backing up, the entire force of this impact is transferred to the master cylinder piston (seal). It is very easy to rupture a seal in this manner.

There are three initial checks that should be performed to insure a proper fit-up on **rotor only** application:

1. Confirm that the rotor will fit over the hub (although there are standard hub flange diameters for the industry standard hubs, some hubs may vary from these standard dimensions). Also confirm that the hub wheel bolts fit through the rotor wheel bolt holes. Below is the flange diameter information for industry standard hubs.

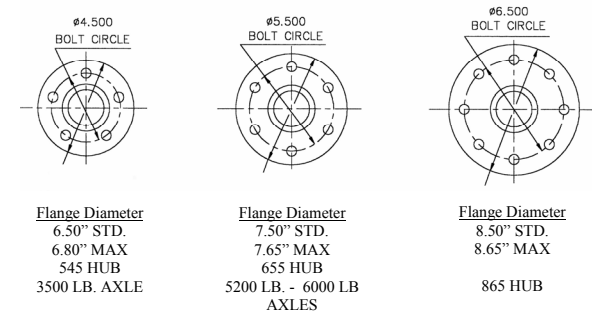

2. Confirm that the wheel bolts are long enough to fully engage the wheel nut after the rotor is installed. See Fig. 2 below.

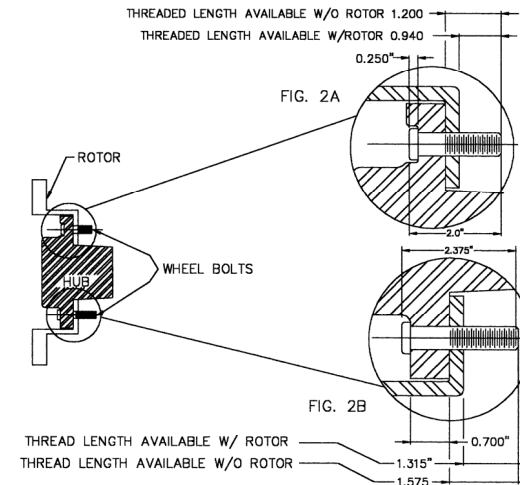
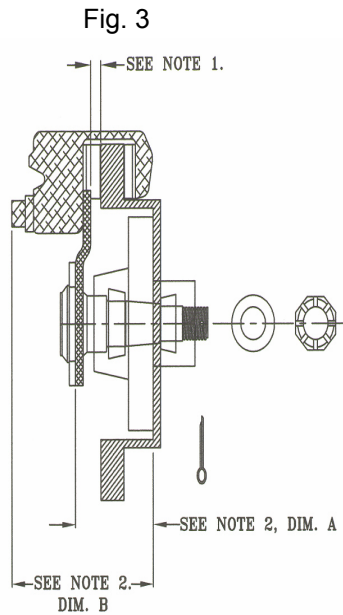

Fig 2. Typical 6000 lb. axle & below

Standard 1/2-20 x 2" wheel bolts countersunk as in Fig. 2 are suitable for most steel wheels and many mag type wheels, depending on the distance that the wheel bolts are countersunk in the hub and the distance wheel nuts are recessed (mag wheels only). Confirm that there is sufficient thread length available for the wheel nut to develop a full strength connection.

3. Confirm that the brake flange was installed correctly. There should be a nominal clearance (See Fig. 3, Note 1) between the outer edge of the caliper mounting bracket and the inner edge of the rotor. Also, this clearance dimension should be the same when measured at either of the two threaded mounting holes.



Notes:

1. This nominal clearance may vary by manufacturer and by size of the axle. Generally, clearance will be between 1/4" and 1/2". After installation of the caliper, confirm that (a) the rotor turns freely (pad drag will decrease substantially after about 100 miles of use), and (b) the caliper will slide (with some effort) on the guide bolt sleeves.

2. Approximate dimensions from hub face are:

	A	B
3500 lb. Axle	3-1/4"	5.6"
5200 lb. Axle	4-3/8"	5.6"
6000 lb. Axle	4-3/8"	5.6"
7000 lb. Axle	4-3/8"	5.7"
8000 lb. Axle	4-35/64" (Dexter)	5.8"
8000 lb. Axle	4-1/2" (Alko)	5.8"
9000 lb. Axle	6-3/4"	9.9"
10,000 lb.		
General Duty Axle	6-3/4"	9.9"

4. After confirmation of 1,2, and 3 on previous pages, installation can proceed, as follows:

- a. Check to see that the flange of the hub is clean and smooth. Remove any rust or corrosion and file smooth any burrs.
- b. Check with a straight edge or on a lathe if possible to insure that the hub is true (i.e., no excessive axial or radial runout). Consult axle manufacturer if total indicator runout exceeds 0.015."
- c. Install rotor and check to see that the rotor fits perfectly to the hub face after assembly. Install three wheel nuts and torque to 10 - 20 foot pounds to temporarily clamp rotor to hub.

d. Rotate hub/rotor assembly and check for ease of rotation and proper concentricity and runout. Note: If runout is excessive, "clock" the rotor (i.e., remove the wheel nuts and reinstall the rotor 180° (or 90°, or 270°, etc.) relative to the hub. Repeat as necessary to minimize runout. Mark this location with a dot for future reference. Remember, the rotor is wheel bolt piloted, so allow for the difference in the rotor wheel bolt hole diameter and the wheel bolt diameter.

e. On 3500 lb. through 8000 lb. axles, install caliper mounting bracket at the recommended 3 o'clock position on left side and 9 o'clock position on right side. On the 9000 lb. and 10,000 lb. axles, the caliper is mounted at 12 o'clock. Torque caliper mounting bracket bolts per axle manufacturer's recommendations. (Note Fig. 1, Item 5)

f. On 3500 lb. through 8000 lb axles, install caliper with bleed screw pointing up. If caliper has two bleed screws, bleed from the highest bleed screw. Torque caliper guide bolts to approximately 40 - 50 foot pounds.

g. After bleeding the system, remove three wheel nuts and install wheel per manufacturer's specifications.

h. When tightening wheel nuts, use an alternating pattern of 1-4-2-5-3 on assemblies with a 5 hole bolt circle. When the bolt pattern is of an even number, tighten opposite pairs until complete. This process will help to insure the concentricity of assembly. Torque wheel nuts per manufacturer's specifications.

i. Avoid the use of power impact tools during re-assembly. Too much initial torque can result in distortion of the assembly, which may increase runout.

Notes:

1. Caliper seals, o'rings, etc., are installed with a special silicone based grease. Petroleum based grease is not compatible with these seals and o'rings. **DO NOT USE PETROLEUM BASED GREASE OR OIL.**
2. This is a floating caliper. **DO NOT PAINT GUIDE BOLTS AND GUIDE BOLT SLEEVES.** Paint will inhibit caliper movement on guide bolt sleeves and on the caliper mounting bracket.