



# BH-200RN41

## BH-200RN41 SPECIFICATIONS



Weight 9.8 lbs.

### IMPORTANT SAFETY INFORMATION:

Maintain adequate vertical (tongue) load to properly control the trailer (generally 10%) but do not exceed the above rated capacities.

**DO NOT** damage the latch. Be particularly careful with the drawbar when coupling and uncoupling.

Other steps and inspections are also required. Consult OSHA and D.O.T. regulations and American Trucking Association for complete coupling and uncoupling procedures. These cover items such as cargo securement, brakes, lights, safety chains, and other important requirements.

This equipment must not be used or maintained in a careless manner.

### GENERAL INFORMATION

1. Do not modify or add to the product.
2. Wear safety goggles during installation, removal and servicing.
3. Never strike any part of the item with a steel hammer.
4. Do not weld on this product.

This product is covered by Holland's Commercial Products Warranty. Holland reserves the right, without giving prior notice, to change specifications and dimensions as designs are altered or improved.

### TOWING APPLICATIONS:

Trailers and equipment designed for over-the-road towing within the stated capacities. For off-road applications, reduce the capacities above by 25% and use in conjunction with a swivel type drawbar. This pintle hook/ball hitch is well suited for use in the utility and construction industries.

### DRAWBAR EYE/BALL HITCH DIMENSIONS:

2.38" to 3" I.D. with 1.25" to 1.63" diameter section with 2" SAE J684 ball hitch coupler.



### Rigid type pintle hook with 2" ball hitch

#### CAPACITY – Pintle Hook:

**4,000 lbs. Maximum Vertical Load**

**20,000 lbs. Maximum Gross Trailer Weight**

#### CAPACITY – 2" Ball Hitch:

**10,000 lbs. Maximum Gross Trailer Weight**  
**Meets SAE J684 Class 4 Standards in a 2" Ball**

#### SAE J847 Information:

Type I - not applicable. Type II - 20,000 lbs.

### MOUNTING:

1. Use a mounting structure of sufficient strength to support the rated capacity of the pintle hook in accordance with SAE J849 and SAE J847 respectively.
2. Use the hole pattern described on the reverse.
3. Use (4) .5" grade 8 fasteners, properly tightened — recommended minimum torque is 60 ft-lb., per SAE J429.

### OPERATING INSTRUCTIONS – PINTLE HOOK:

1. Before operating, inspect for proper operation, worn, damaged or missing parts and secure mounting. Correct as required before use.
2. Open the latch (A) by lifting the lock handle (B).
3. Position drawbar eye over the horn of the pintle hook and lower into place.
4. Push the latch (A) closed. When locked, the lock handle (B) will rotate and move down until it flush with the top of the latch.
5. If main lock does not engage when attempting to close latch, do not force it closed by striking. Check bottom of latch and top of horn and lock seating notch on pintle body that they are free of debris.

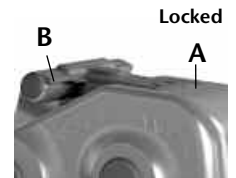

CORRECT

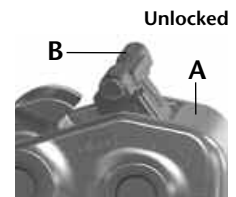

INCORRECT

### OPERATING INSTRUCTIONS – BALL HITCH:

1. Before operating, inspect for proper operation, worn, damaged or missing parts and secure mounting. Correct as required before use.
2. Open latch (A) and lift the lock handle (B).
3. Position ball coupler over the 2" ball and lock into place, following the instructions of the coupler manufacturer. Be sure coupler size matches ball size.

**MAINTENANCE:**

For proper performance, the following maintenance steps should be performed every 30,000 miles or 3 months, whichever comes first.

1. Clean and inspect for work, damaged, or missing parts. Replace as required using only Holland parts.
2. Inspect the hook (XA-10799-2) and latch sub-assembly (XA-10636) in areas where contact is made with the drawbar for excessive wear. Replace the hook when

wear exceeds 1/8" (0.125") from the original surface profile.

3. With the latch closed, measure the gap between the hook and the latch while lifting up on the latch. Replace the latch (XA-10636 sub-assembly) when the gap exceeds 1/4" (0.25"). See Detail A.
4. Check mounting fasteners as instructed in Step 3 of the "Mounting" section.

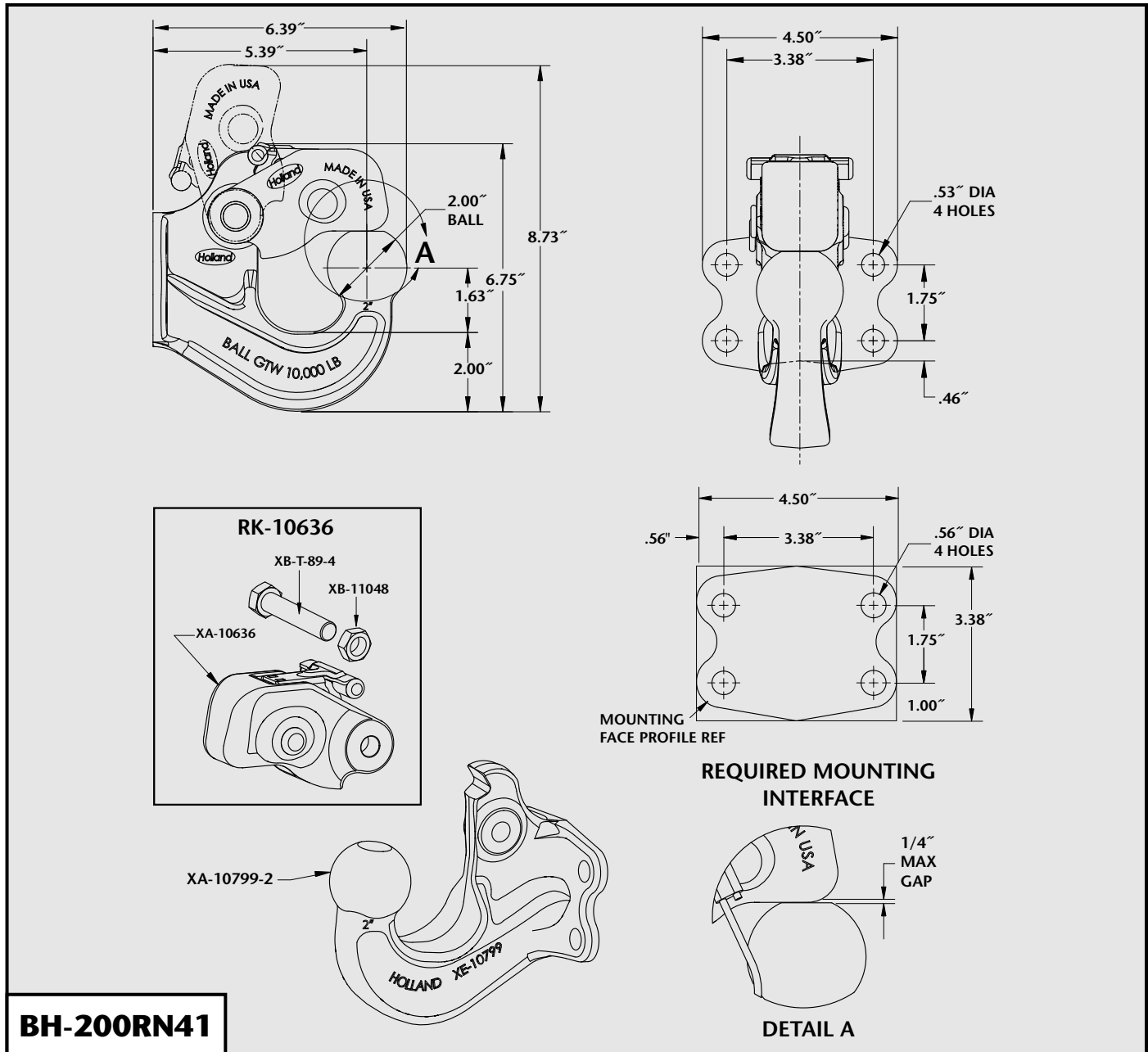

SAF-HOLLAND USA, Inc.  
888.396.6501 Fax 800.356.3929

SAF-HOLLAND Canada Limited  
519.537.3494 Fax 800.565.7753  
Western Canada  
604.574.7491 Fax 604.574.0244

SAF-HOLLAND International, Inc.  
616.396.6501 Fax 616.356.1511